

## SUBMERSIBLE SEWAGE PUMPS (GRINDER)

in cast iron



SINGLE PHASE



THREE PHASE



Submersible sewage pumps with open impeller and grinder device inlet

### APPLICATIONS

- Evacuation of civil and industrial waste waters
- Moving foul waste water with filamentary substances and paper
- Emptying cesspits
- Emptying seepage water

### TECHNICAL DETAILS

- Open impeller and grinder device inlet

### TECHNICAL DATA

- Maximum temperature of the liquid: 40°C
- Max solids size for passage: 6÷7mm
- Single and three phase asynchronous motor
- Versions available: 2 poles
- Insulation class: H
- Protection degree: IP68
- 230V ±10%, 50Hz single phase voltage
- 400V ±10%, 400/690±10%, 50Hz three phase voltage
- Flanges DN40
- Power up to 5 kW

### MATERIALS

- Pump body, grinder impeller, motor pump body, volute base, upper cover in cast iron
- Shaft in AISI 420B
- Mechanical seal: SiC/SiC/NBR (pump side)  
Carbon/Ceramic/NBR (motor side) (3,2kW and above)

### ACCESSORIES (ON REQUEST)

- See from page 134

### PUMP IDENTIFICATION CODE

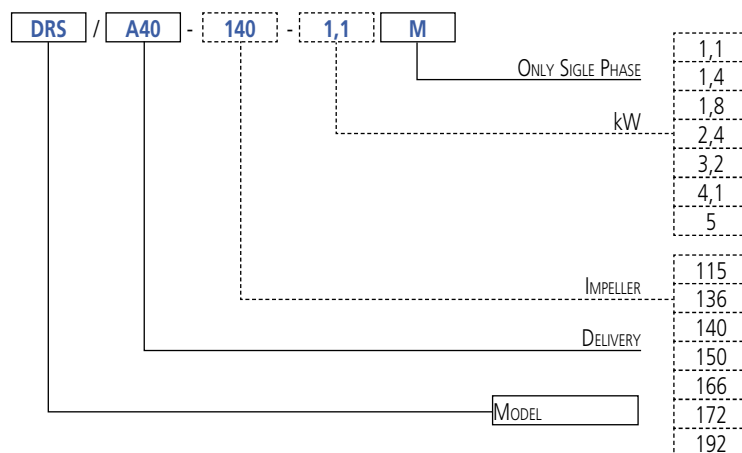

## SUBMERSIBLE SEWAGE PUMPS (GRINDER)

in cast iron

### PERFORMANCE CHART

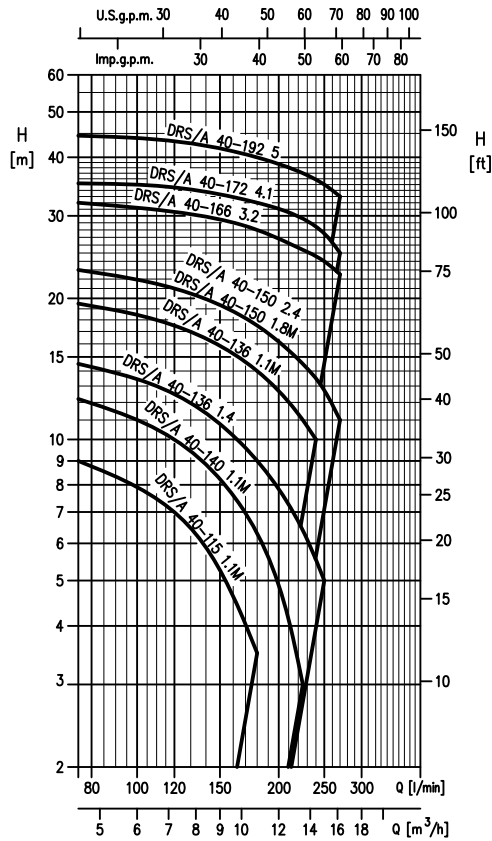

### PERFORMANCE TABLE

Model	P <sub>2</sub>		Q=Flow rate						
	[HP]	[kW]	l/min m <sup>3</sup> /h	75 5	120 7	180 11	225 14	240 14	270 16
			H=Head [m]						
DRS/A40-115-1.1 M	1,5	1,1	9	7	3,5	-	-	-	-
DRS/A40-140-1.1 M	1,5	1,1	12,2	10	6,3	3	-	-	-
DRS/A40-136-1.1 M	1,5	1,1	19,5	17,5	14	11	10	-	-
DRS/A40-150-1.8 M	2,5	1,8	23	21	17,5	14,5	13,5	11	-
DRS/A40-136-1.4	2	1,4	14,5	12,5	9	6,3	5	-	-
DRS/A40-150-2.4	3,2	2,4	23	21	17,5	15	13,9	11,5	-
DRS/A40-166-3.2	4,5	3,2	32	30,6	28	25,4	24,4	22,5	-
DRS/A40-172-4.1	5,5	4,1	35,2	34,5	32	29,6	28,1	25	-
DRS/A40-192-5,0	7	5	44,5	43,5	40	37	35,9	33	-

The contents of this publication must not be regarded as binding. EBARA Pumps Europe S.p.A. reserves the right to effect any modification it deems necessary, without prior notice.

## SUBMERSIBLE SEWAGE PUMPS (GRINDER)

in cast iron

### PERFORMANCE CURVES

DRS/A40-115-1.1M (1.1 kW) – Impeller Diameter = 115 mm  
 DRS/A40-140-1.1M (1.1 kW) – Impeller Diameter = 140 mm  
 DRS/A40-136-1.1M (1.1 kW) – Impeller Diameter = 136 mm  
 DRS/A40-150-1.8M (1.8 kW) – Impeller Diameter = 150 mm

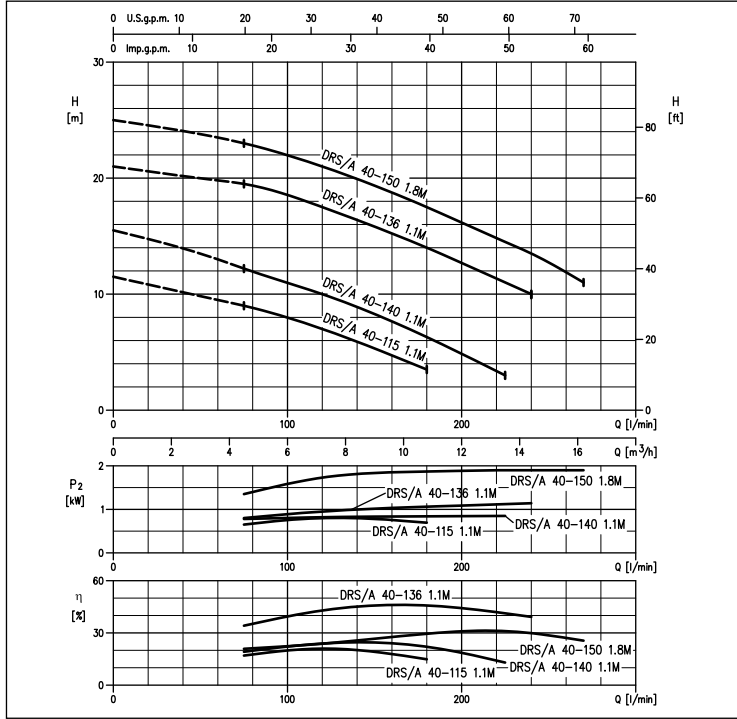

### PERFORMANCE CURVES

DRS/A40-136-1.4 (1.4 kW) – Impeller Diameter = 136 mm  
 DRS/A40-150-2.4 (2.4 kW) – Impeller Diameter = 150 mm

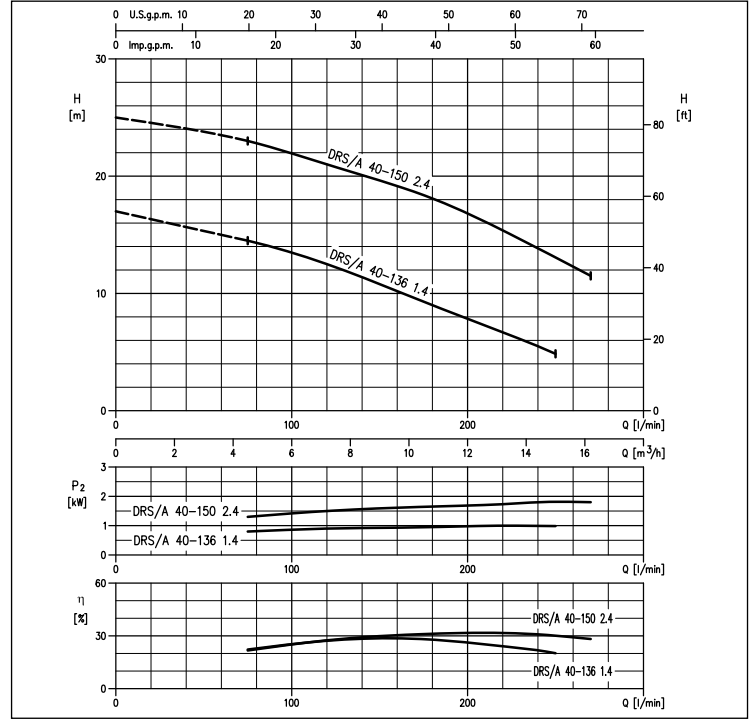

### PERFORMANCE CURVES

DRS/A40-166-3.2 (3.2 kW) - Impeller Diameter = 166 mm  
 DRS/A40-172-4.1 (4.1 kW) - Impeller Diameter = 172 mm  
 DRS/A40-192-5 (5.0 kW) - Impeller Diameter = 192 mm

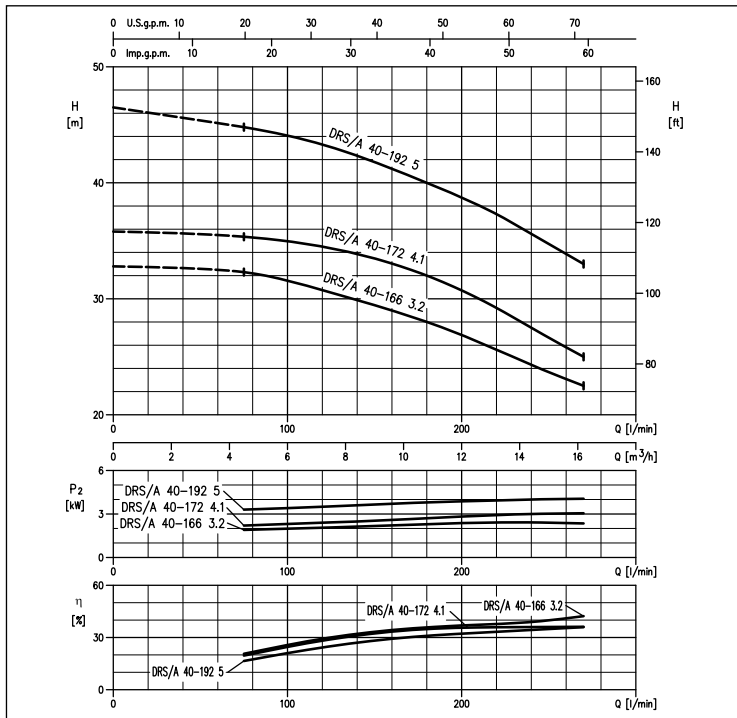

## SUBMERSIBLE SEWAGE PUMPS (GRINDER)

in cast iron

### DIMENSIONS DRS/A 40 (1.1 kW)

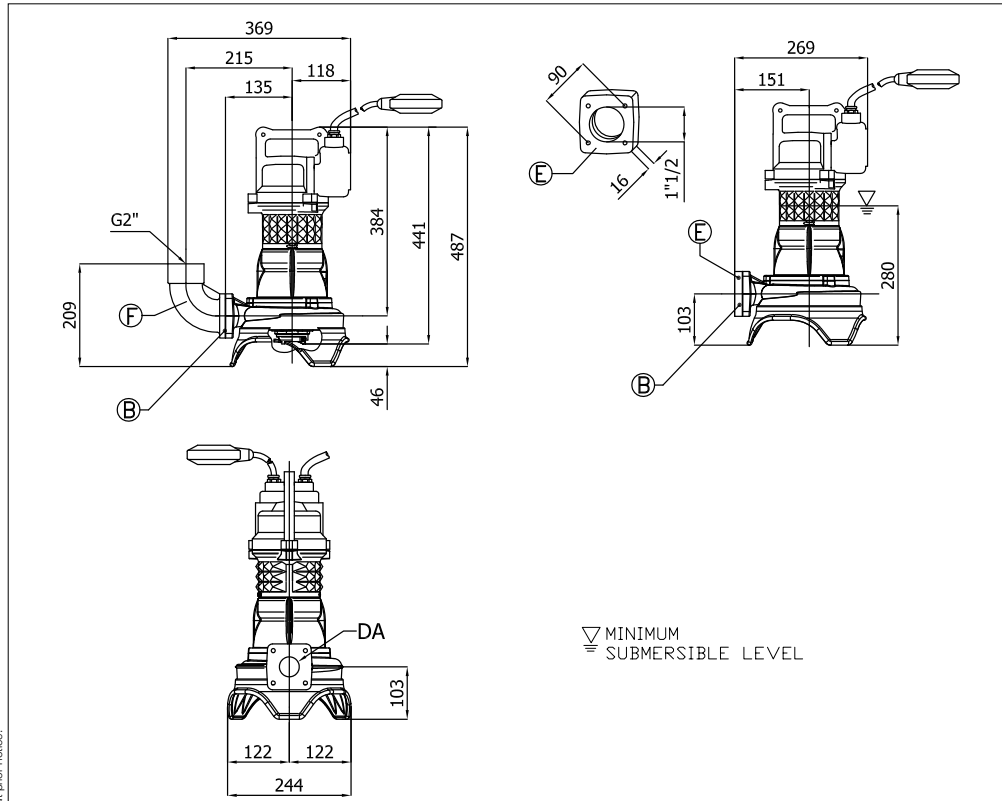

### DIMENSIONS TABLE DRS/A 40 (1.1 kW)

DA	Model	[kW]	Weight [kg]
40	DRS/A40-140-1,1M	1.1	30
	DRS/A40-115-1,1M	1.1	30

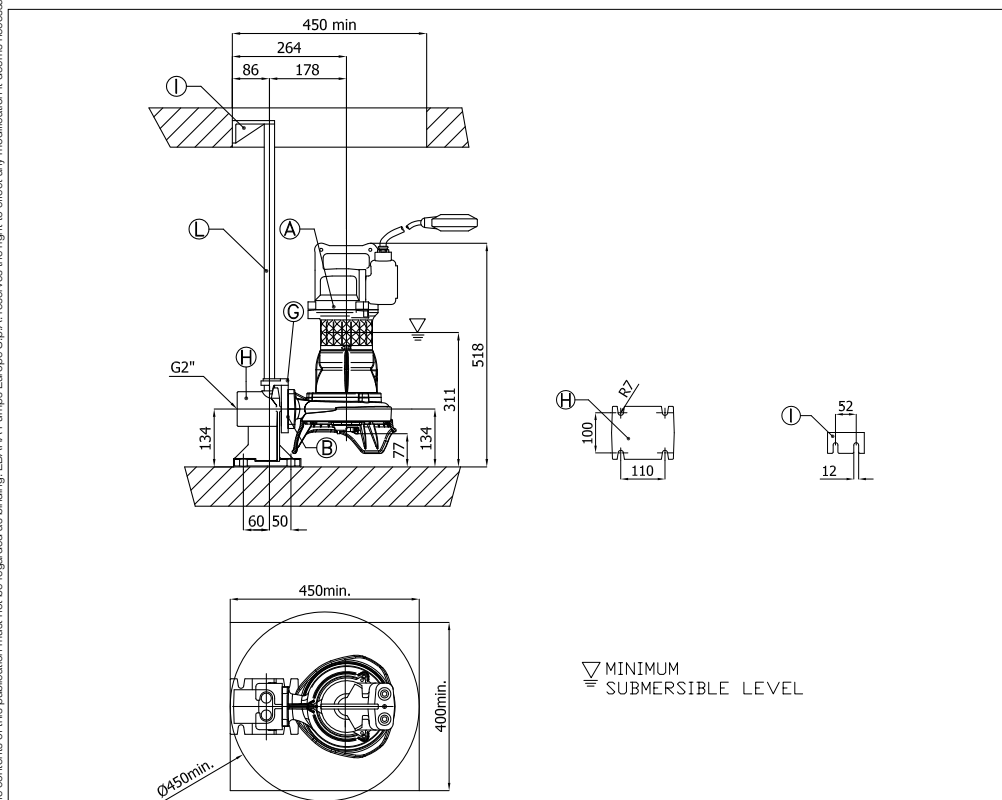

The contents of this publication must not be regarded as binding. EBARA Pumps Europe S.p.A. reserves the right to effect any modification it deems necessary, without prior notice.

## SUBMERSIBLE SEWAGE PUMPS (GRINDER)

in cast iron

### DIMENSIONS DRS/A 40 (1.1÷1.8 kW)

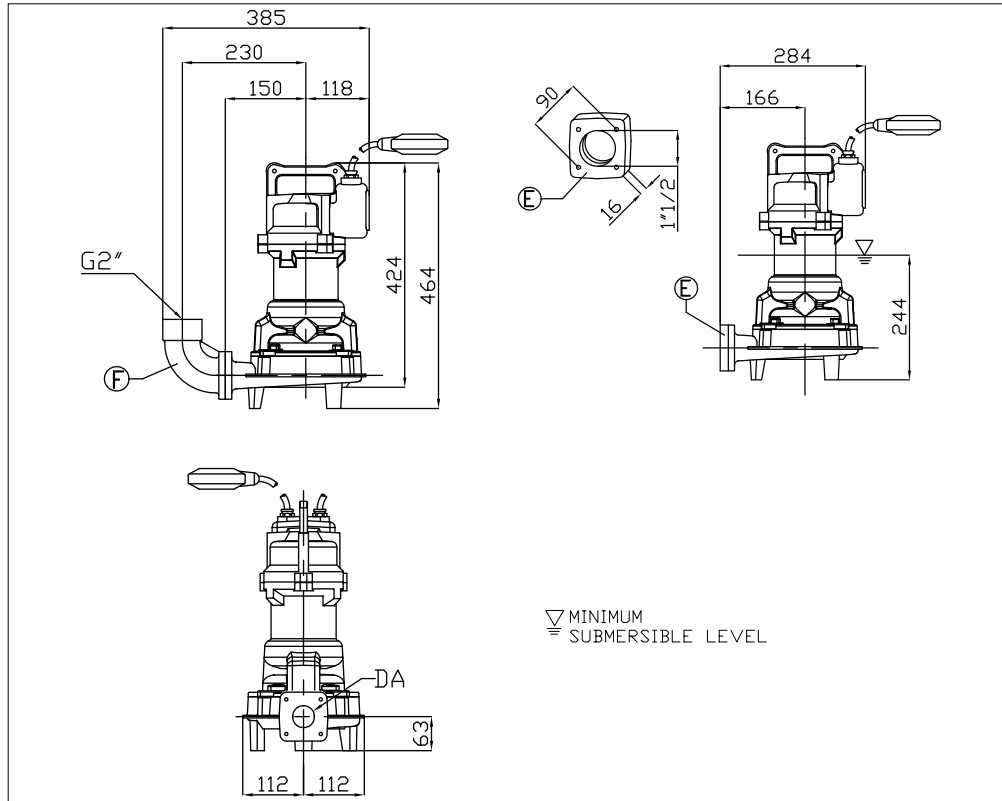

### DIMENSIONS TABLE DRS/A 40 (1.1÷1.8 kW)

DA	Model	[kW]	Weight [kg]
40	DRS/A40-136-1,1M	1.1	40
	DRS/A40-150-1,8M	1.8	

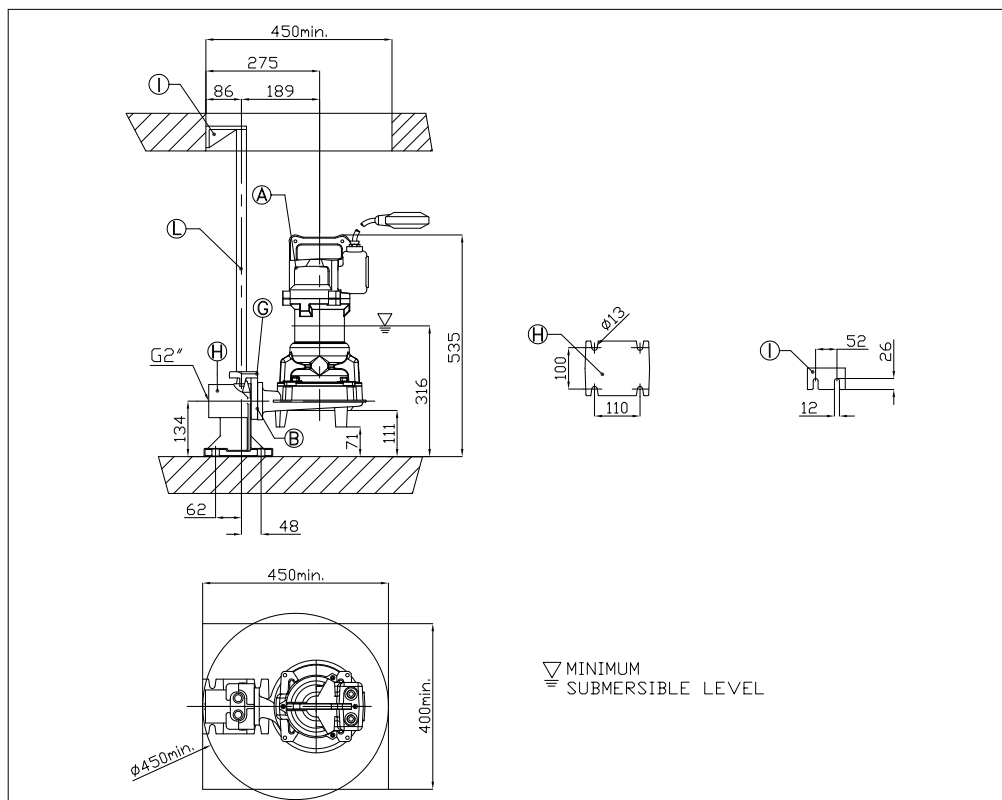

The contents of this publication must not be regarded as binding. EBARA Pumps Europe S.p.A. reserves the right to effect any modification it deems necessary, without prior notice.

## SUBMERSIBLE SEWAGE PUMPS (GRINDER)

in cast iron

### DIMENSIONS DRS/A 40 (1.4 kW)

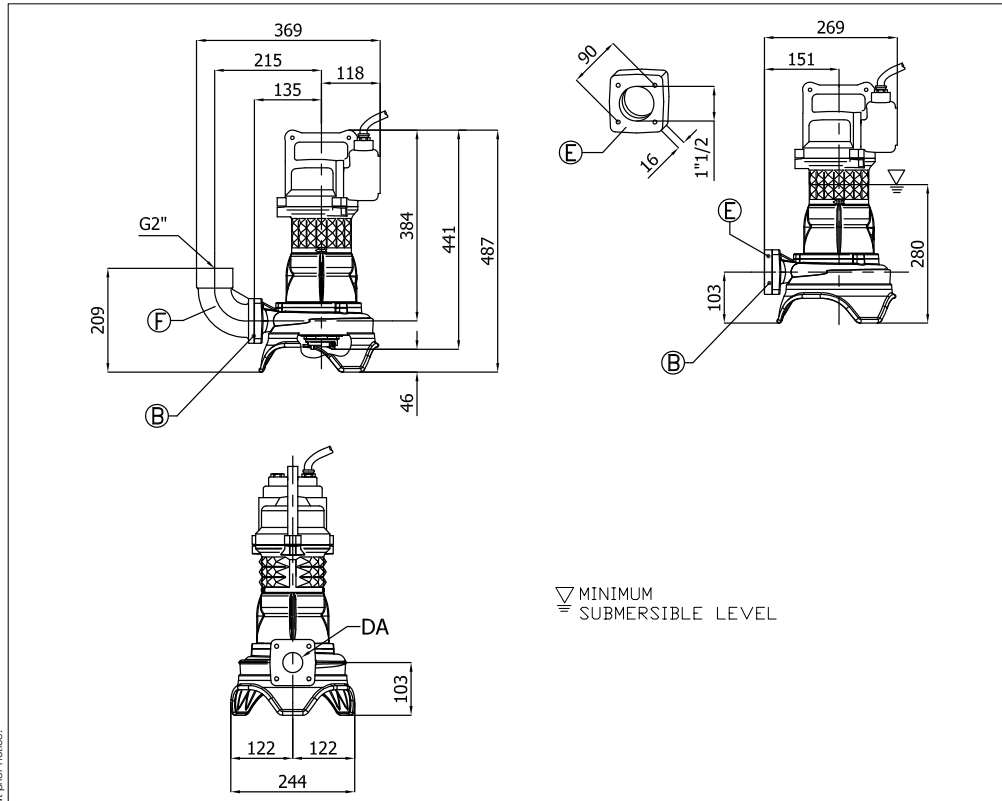

### DIMENSIONS TABLE DRS/A 40 (1.4 kW)

DA	Model	[kW]	Weight [kg]
40	DRS/A40-136-1,4	1.4	40

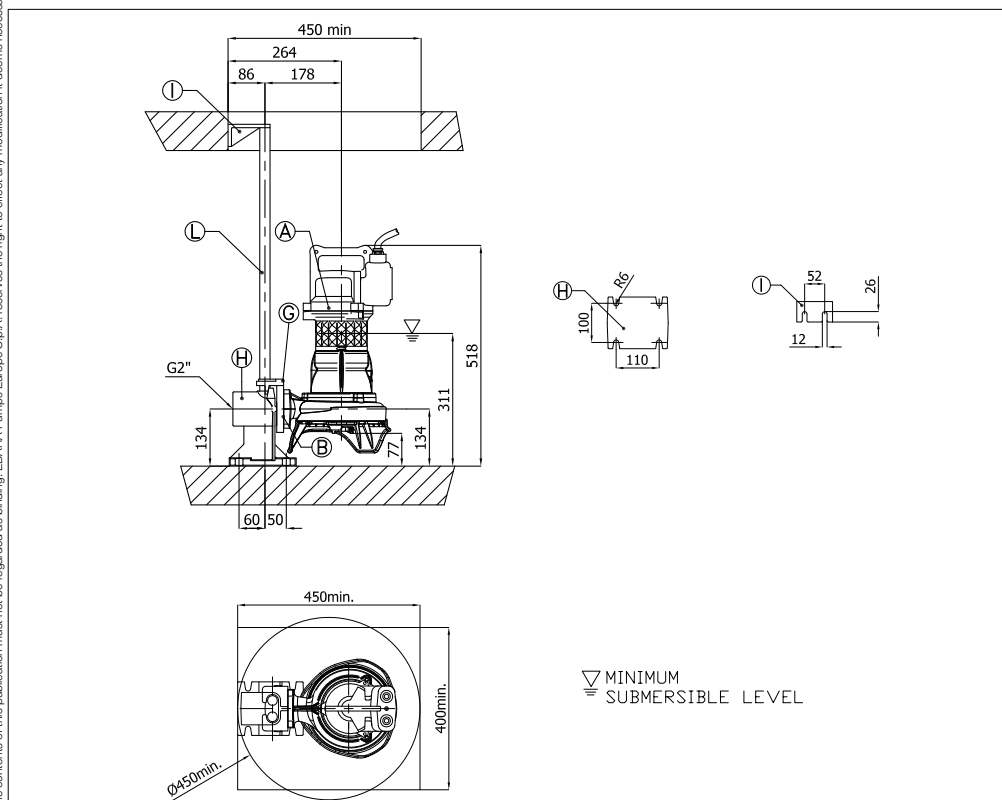

The contents of this publication must not be regarded as binding. EBARA Pumps Europe S.p.A. reserves the right to effect any modification it deems necessary, without prior notice.

## SUBMERSIBLE SEWAGE PUMPS (GRINDER)

in cast iron

### DIMENSIONS DRS/A 40 (2.4 kW)

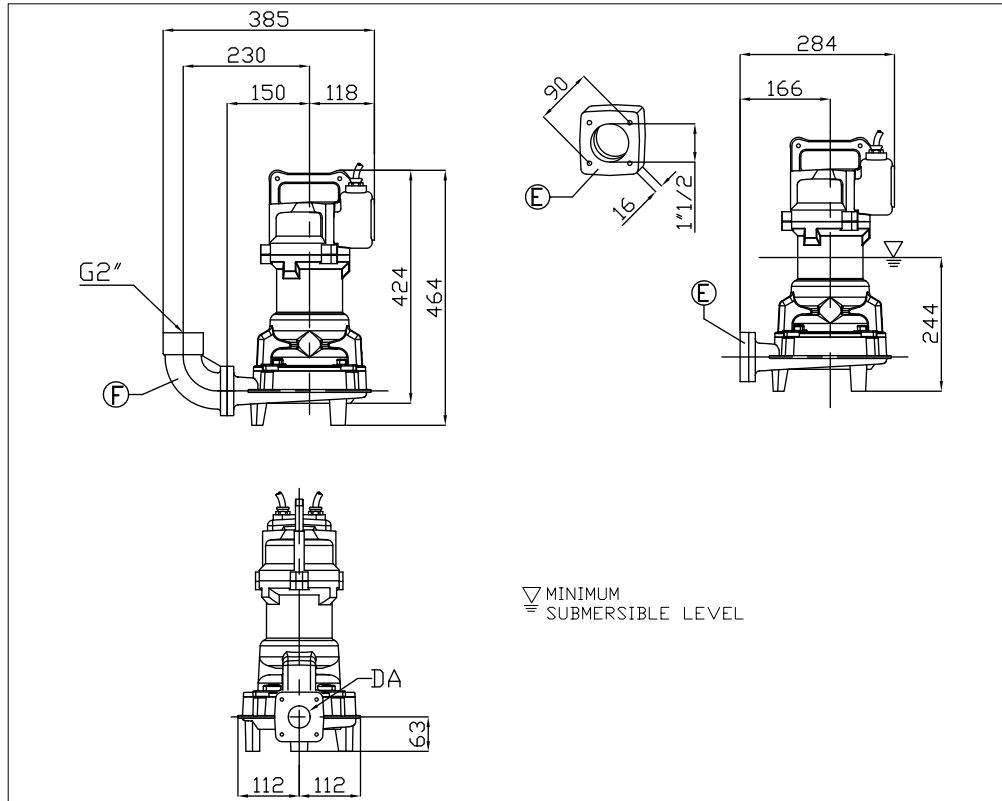

### DIMENSIONS TABLE DRS/A 40 (2.4 kW)

DA	Model	[kW]	Weight [kg]
40	DRS/A40-150-2,4	2.4	40

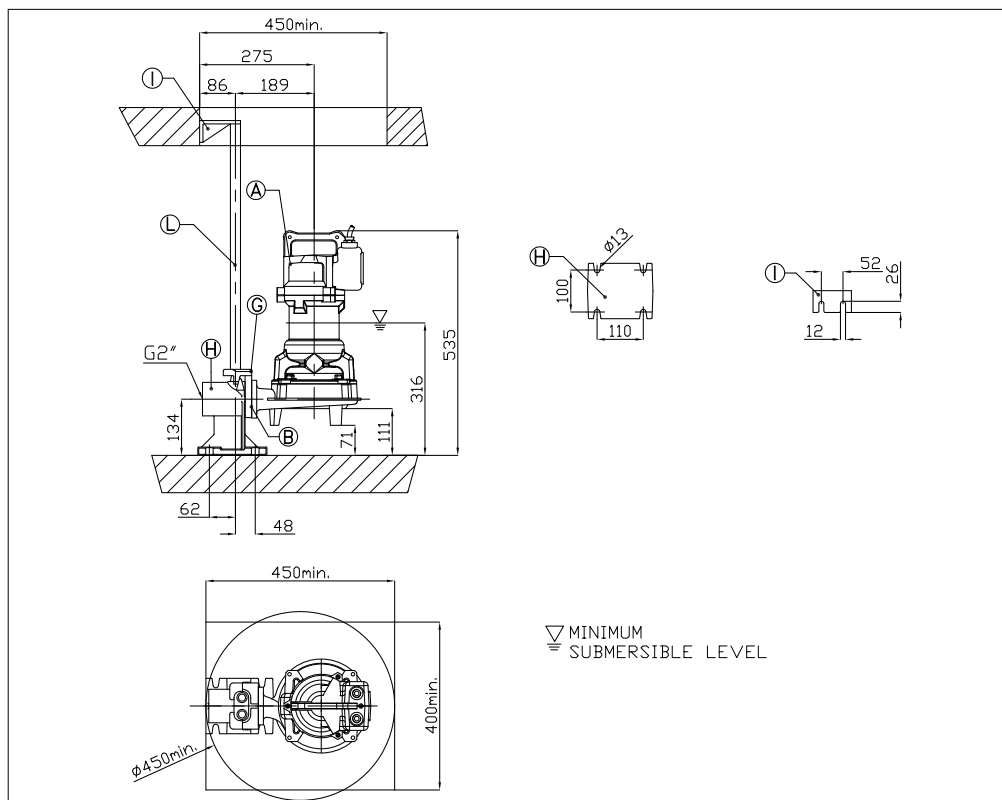

## SUBMERSIBLE SEWAGE PUMPS (GRINDER)

in cast iron

### DIMENSIONS DRS/A 40 (3.2 kW)

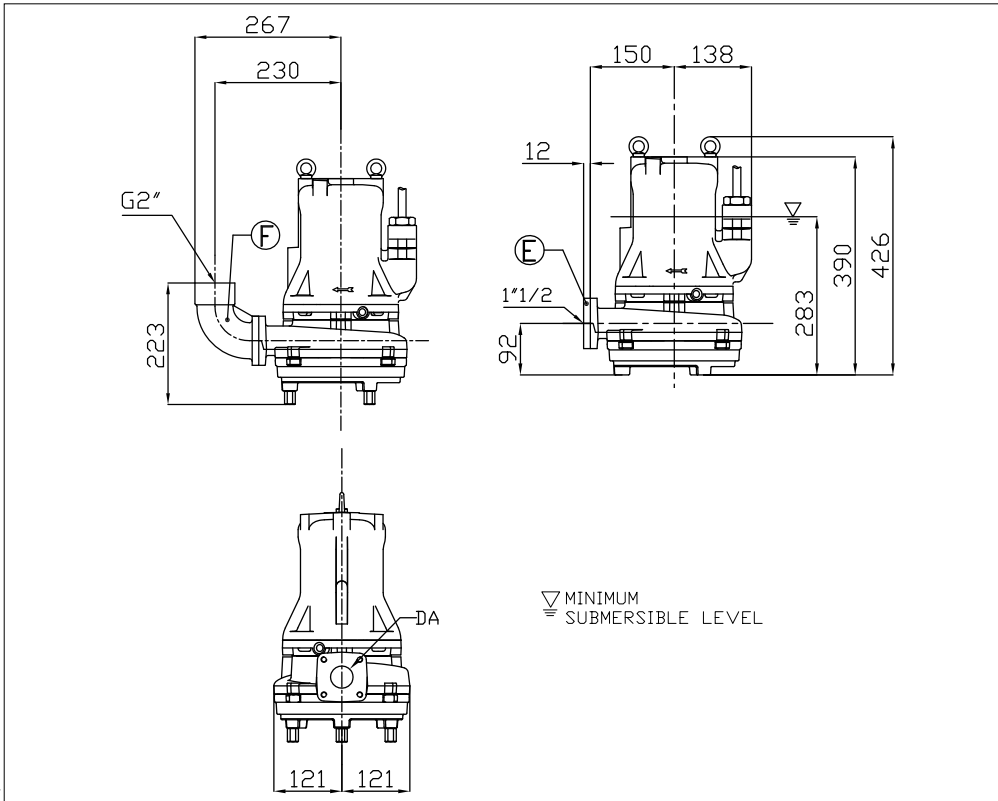

### DIMENSIONS TABLE DRS/A 40 (3.2 kW)

DA	Model	[kW]	Weight [kg]
40	DRS/A40-166-3,2	3.2	52

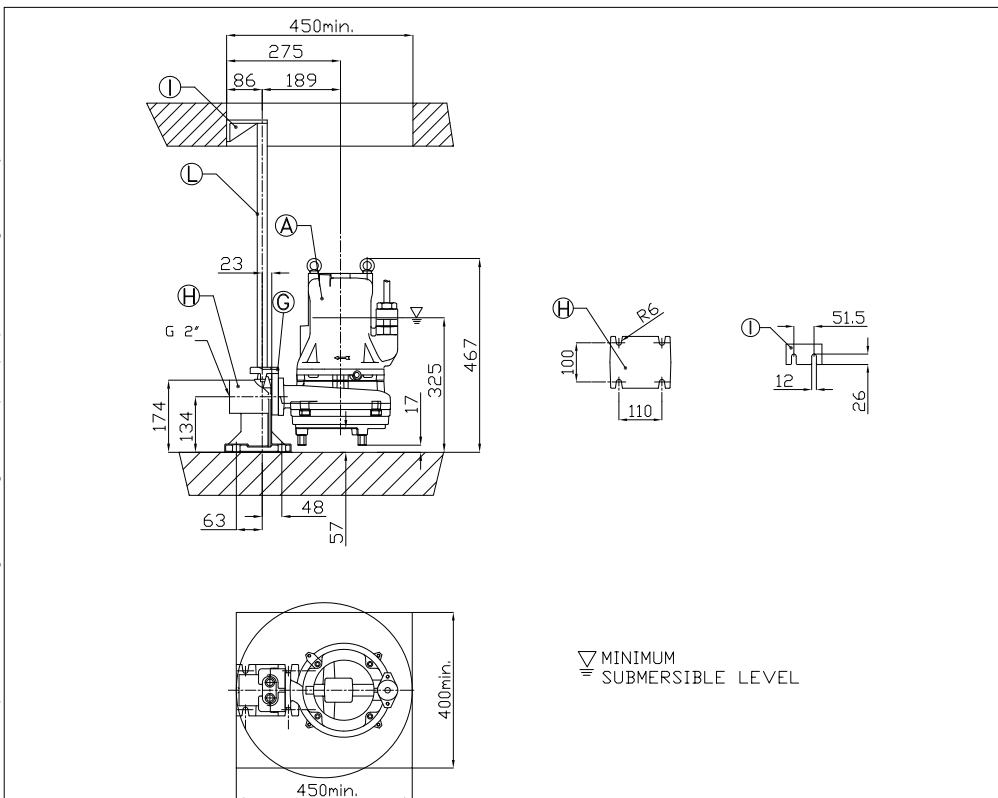

The contents of this publication must not be regarded as binding. EBARA Pumps Europe S.p.A. reserves the right to effect any modification it deems necessary, without prior notice.



## SUBMERSIBLE SEWAGE PUMPS (GRINDER)

in cast iron

### DIMENSIONS DRS/A 40 (4.1÷5 kW)

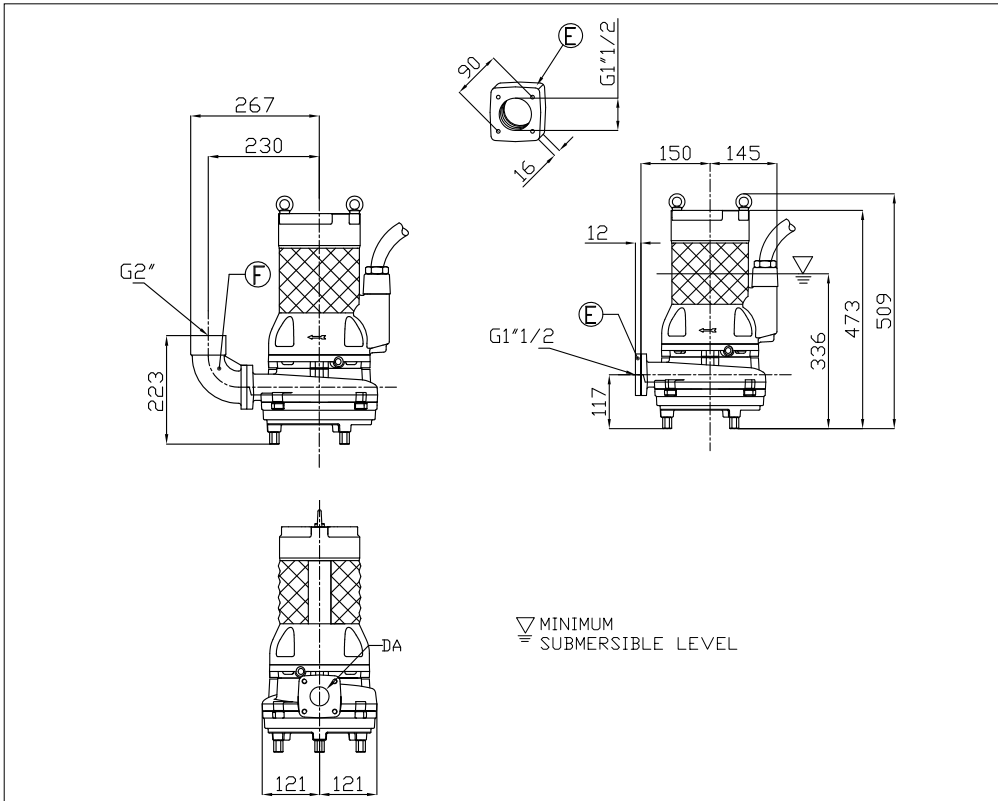

### DIMENSIONS TABLE DRS/A 40 (4.1÷5 kW)

DA	Model	[kW]	Weight [kg]
40	DRS/A40-172-4,1	4.1	66
	DRS/A40-192-5	5	66

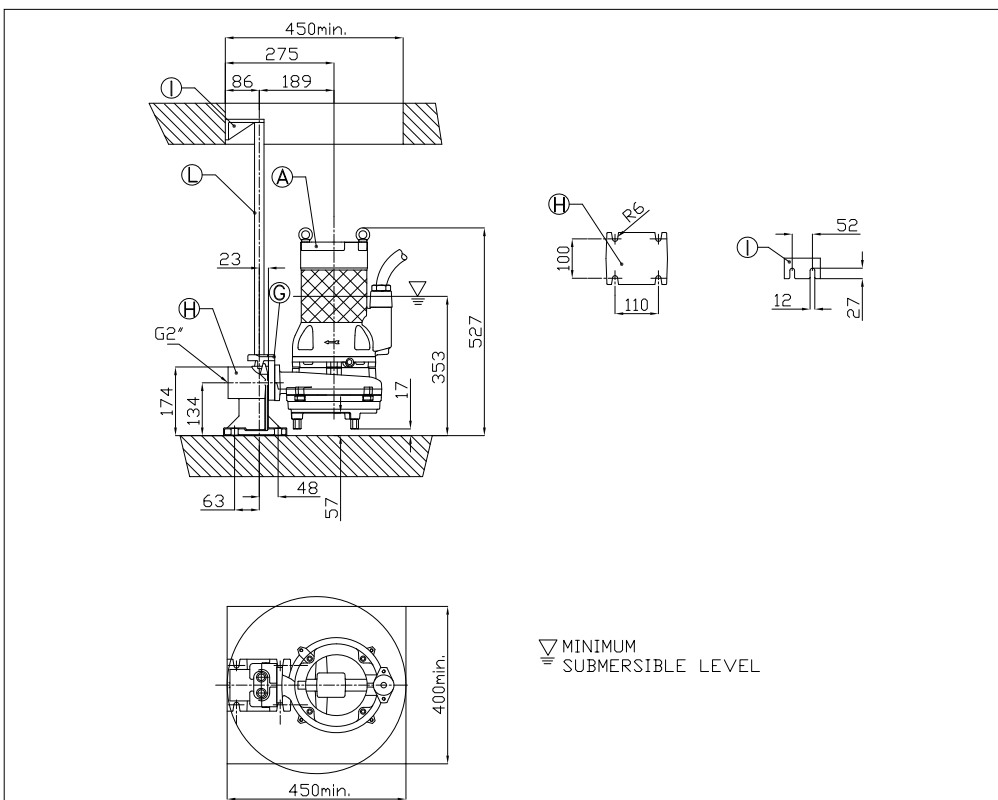

The contents of this publication must not be regarded as binding. EBARA Pumps Europe S.p.A. reserves the right to effect any modification it deems necessary, without prior notice.

## SUBMERSIBLE SEWAGE PUMPS (GRINDER)

in cast iron

**SECTIONAL VIEW DRS/A40-115M(1.1 kW)  
DRS/A40-140M (1.1 kW)**

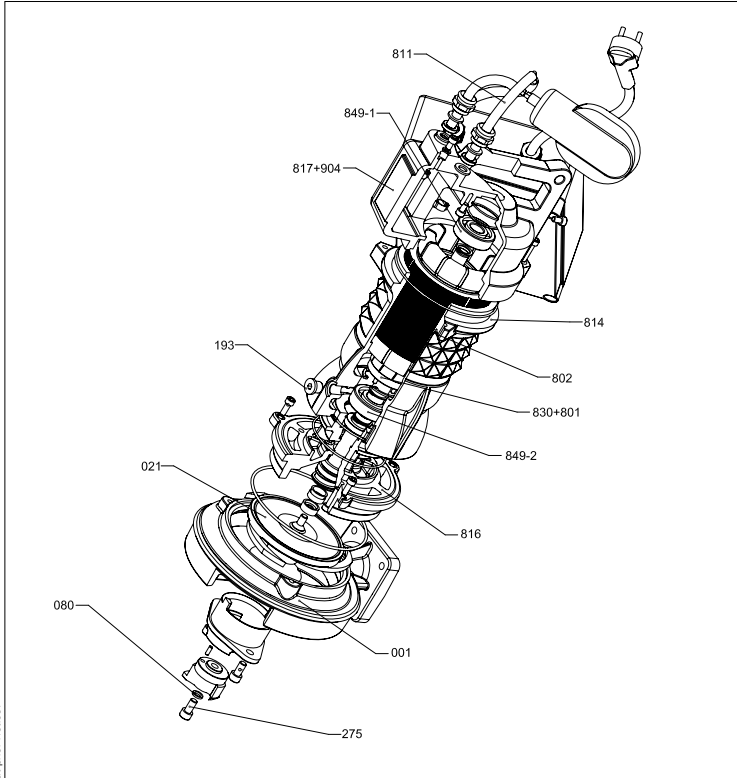

**SECTIONAL VIEW DRS/A 40-136M (1.1 kW)**

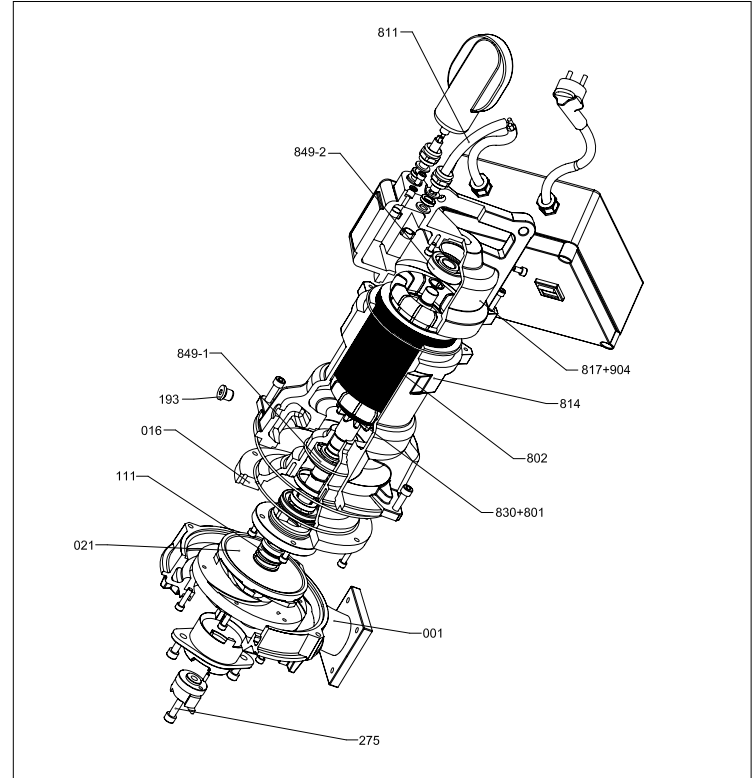

**SECTIONAL VIEW DRS/A 40-136 (1.4 kW)**

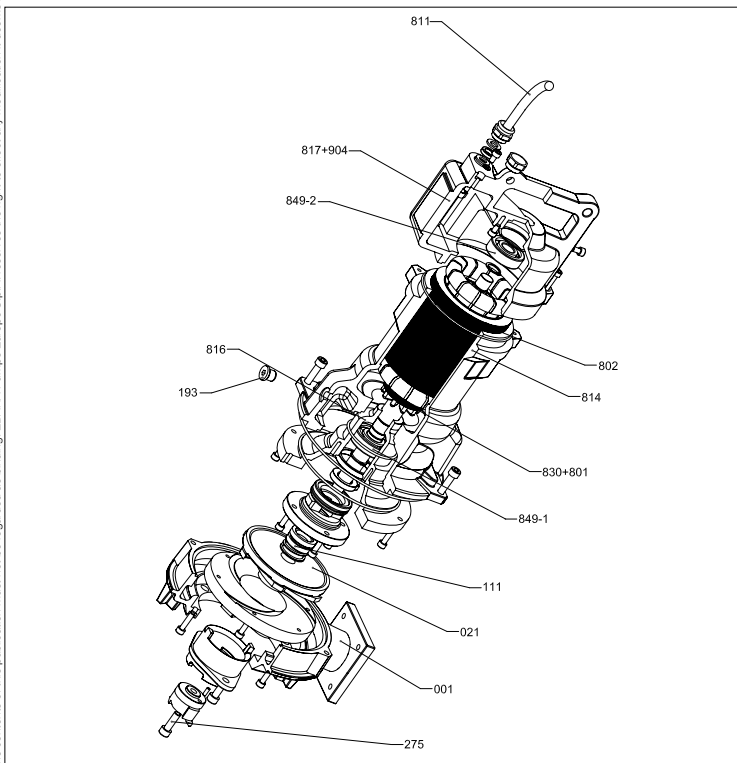

**SECTIONAL VIEW DRS/A 40-150M (1.8 kW)**

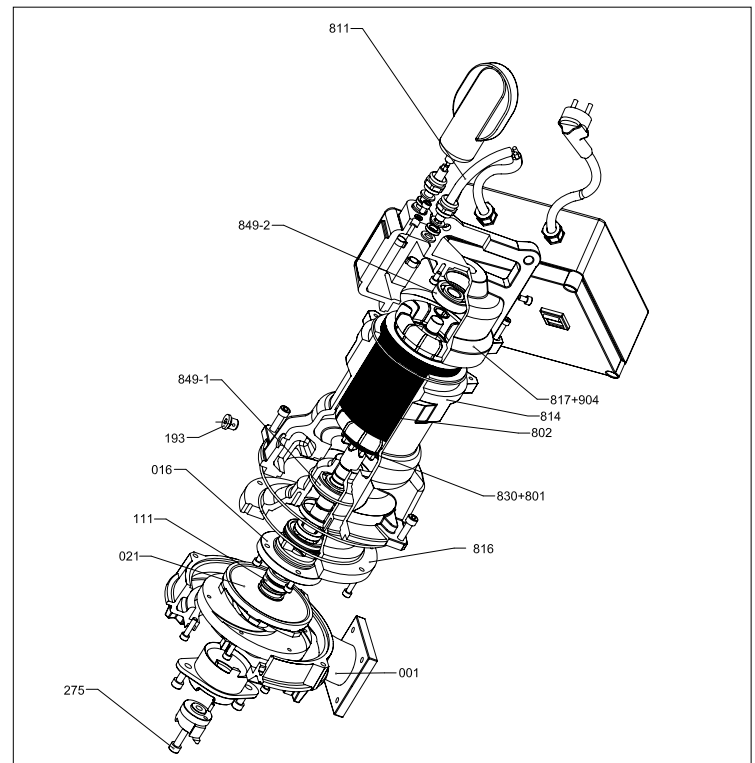

The contents of this publication must not be regarded as binding. EBARA Pumps Europe S.p.A. reserves the right to effect any modification it deems necessary, without prior notice.

## SUBMERSIBLE SEWAGE PUMPS (GRINDER)

in cast iron

SECTIONAL VIEW DRS/A 40-150 (2.4 kW)

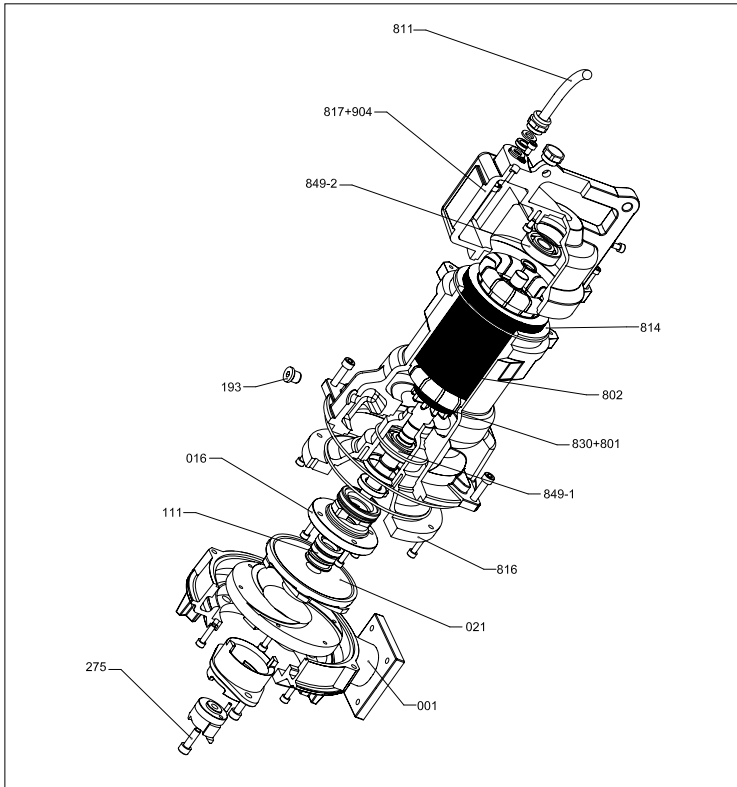

SECTIONAL VIEW DRS/A 40-166 (3.2 kW)

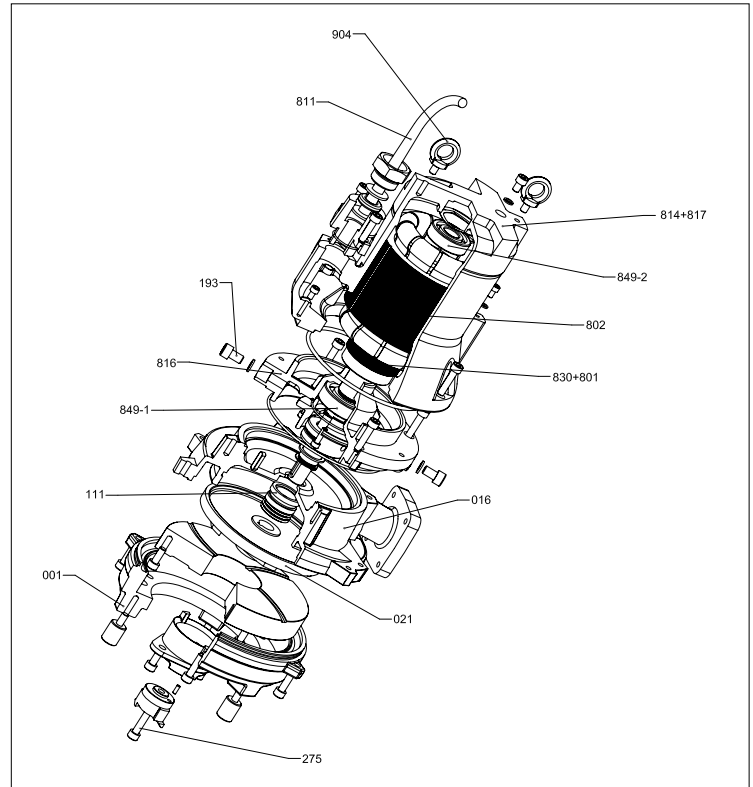

SECTIONAL VIEW DRS/A 40-172 (4.1 kW)

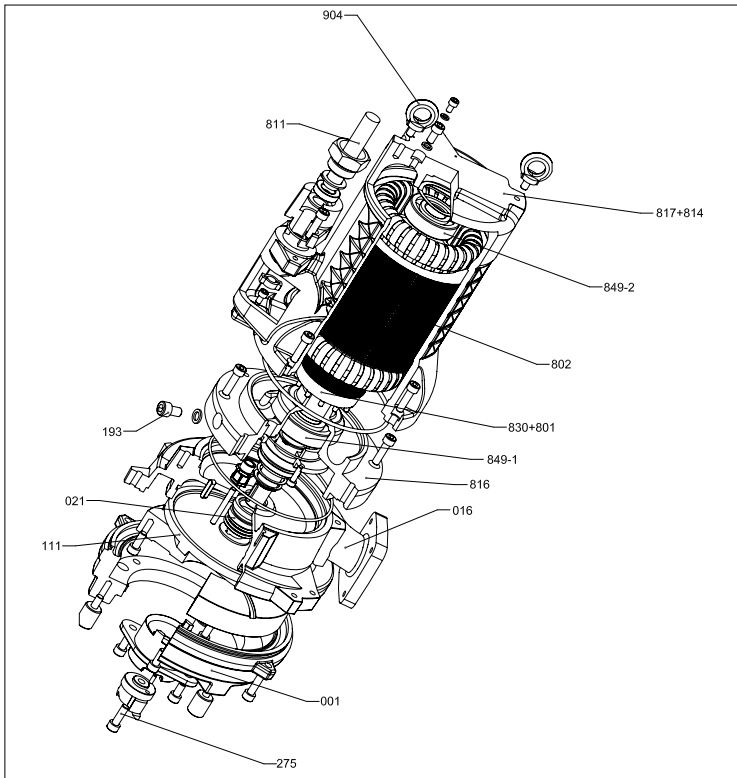

SECTIONAL VIEW DRS/A 40-192 (5.0 kW)

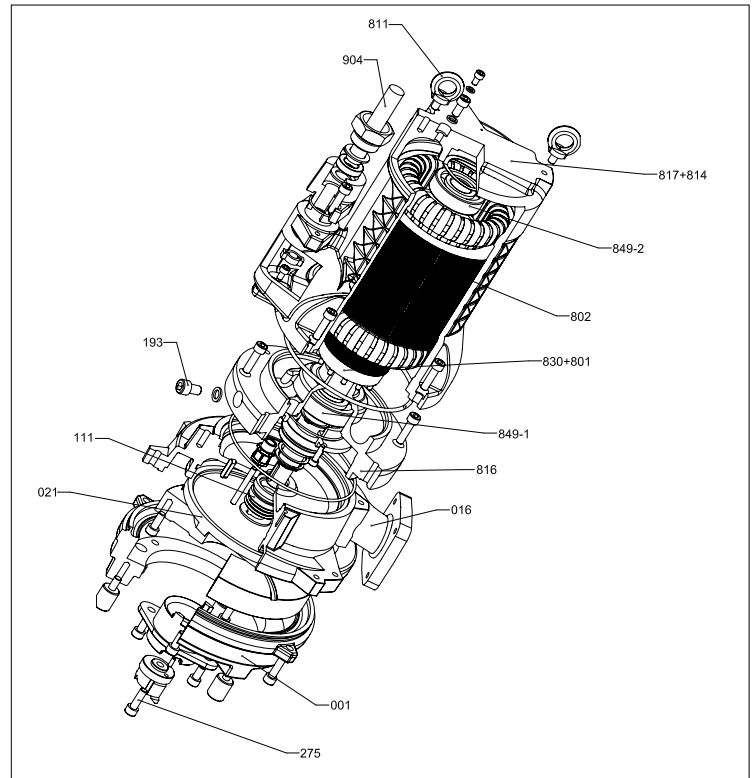

The contents of this publication must not be regarded as binding. EBARA Pumps Europe S.p.A. reserves the right to effect any modification it deems necessary, without prior notice.

## SUBMERSIBLE SEWAGE PUMPS (GRINDER)

in cast iron

### MATERIALS TABLE DRS

Ref.	Name	Material	Ref.	Name	Material
001	Pump body	CAST IRON	811	Cable	-
016	Mechanical seal cover	CAST IRON	814	Motor case	CAST IRON
021	Impeller	DUCTILE IRON	816	Power side bracket	CAST IRON
080	Bushing	STEEL	817	Opposite side bracket	CAST IRON
111	Mechanical seal	-	830	Shaft	AISI 420B
193	Oil plug	NBR/STAINLESS STEEL	849-1	Ball bearing	-
275	Impeller nut	AISI304 CLASSE A2	849-2	Ball bearing	-
801	Stator	-	904	Lifting hanger	CAST IRON [1]/STEEL [2]
802	Rotor	-			

[1] - DRS/A 40-115(1.1kW), DRS/A 40-140 (1.1.kW), DRS/A 40-136 (1.1 /1.4 kW), DRS/A 40-150 (1.8/2.4 kW)

[2] -DRS/A 40-166 (3.2 kW), DRS/A 40-172 (4 kW), DRS/A 40-192 (5.0 kW)

### DRS MOTOR DATA

[P2]	[kW]	1,1 (DRS 40-115) (DRS 40-140)	1,1 (DRS 40-136)	1,8	1,4	2,4	3,2	4,1	5		
Resistance at 20°C	[Ω]	2,83/6,48	1,97/4,38	1,9/4,3	3,100	3,000	2,060	2,920	2,870		
GD <sup>2</sup>	[kg·m <sup>2</sup> ]	0,000430	0,000520	0,000520	0,001	0,001	0,002	0,003	0,003		
Voltage	[V]	230	230	230	400	400	400	400	400		
Load	0%	Current	[A]	3,3	2,31	2,5	2,6	2,8	2,6	4,3	4,6
		Power	[W]	560	415	420	420	440	480	720	745
	75%	Current	[A]	5,5	5,4	7,6	2,6	3,8	4,88	7,3	7,8
		Efficiency	[%]	67	67	80	77	79	86	83	83
		Power factor	[%]	0,95	0,96	0,98	0,74	0,85	0,82	0,75	0,83
	100%	Speed	[min <sup>-1</sup> ]	2820	2868	2795	2908	2820	2838	2918	2898
		Current	[A]	7,5	7,5	10	3,5	5	6,5	8,8	11
		Efficiency	[%]	68	68	80,5	77	79	86	83	83
		Power factor	[%]	0,98	0,98	0,99	0,83	0,9	0,85	0,82	0,88
Speed	[min <sup>-1</sup> ]	2750	2750	2710	2810	2720	2770	2850	2850		
Locked Rotor Torque	[%]	20	20	30	300	300	240	260	260		
Start Current	[A]	21	21	35	14	21	31,9	51,9	64,9		
Fase		1			3						
No. starts per hour		15									
Model		M272M/L 9108-394 9756	M271M/M 2282 - 3028 3534-6437	M271M/L 3026-3536 5432-5372 6436	M271T/M-2051	M271T/L-2050	M209T/LLR-1042	M210T/S-1924	M210T/M-1600		