



atac

ATAC Solutions Ltd is a leading environmental engineering company based in Maidstone, United Kingdom.

ATAC Solutions is known for its state-of-the-art liquid collection fleet and its expertise in providing bespoke turnkey wastewater process solutions.

With a focus on sustainability and accreditation in ISO 9001 & ISO 14001, the company serves domestic and industrial clients across the South-East and London.

ATAC Solutions Ltd,
Unit A9, Loc 8 Business Park, Ashford Road,
Hollingbourne, Maidstone, England, ME17 1WR

 [atacsolutions.com](https://www.atacsolutions.com)
 01622 882400

Axiom Water companies



Wilo-Stratos/-D/-Z/-ZD

D Einbau- und Betriebsanleitung

GB Installation and operating instructions

F Notice de montage et de mise en service

NL Inbouw- en bedieningsvoorschriften

Fig. 1a:

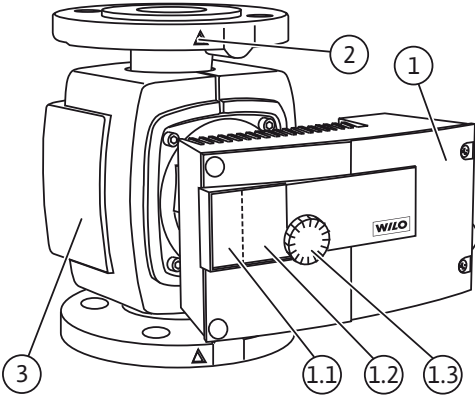

Fig. 1b:

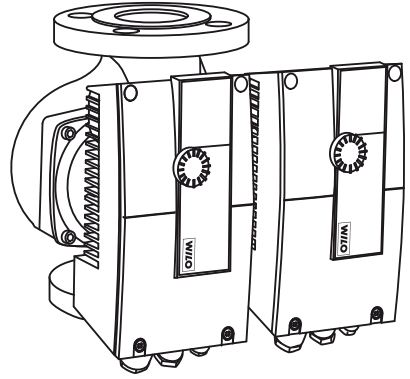

Fig. 2a:

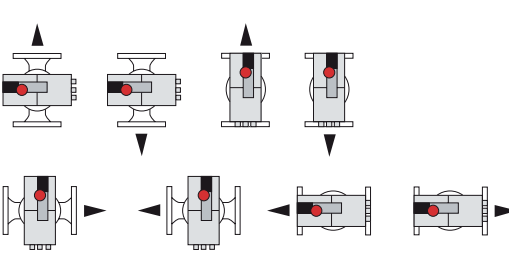

Fig. 2b:

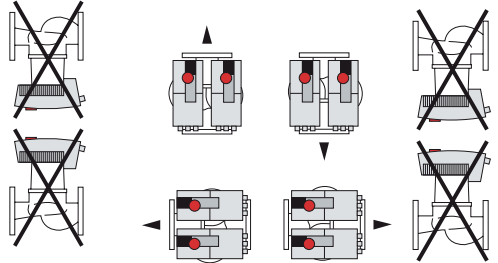

Fig. 3:

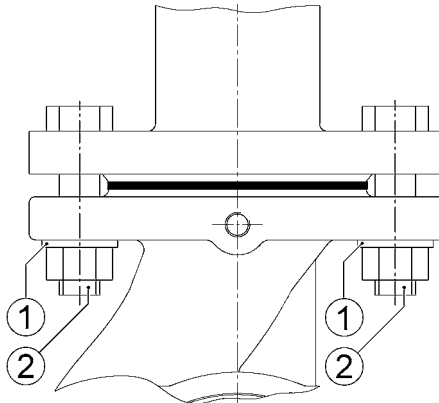

Fig. 4:

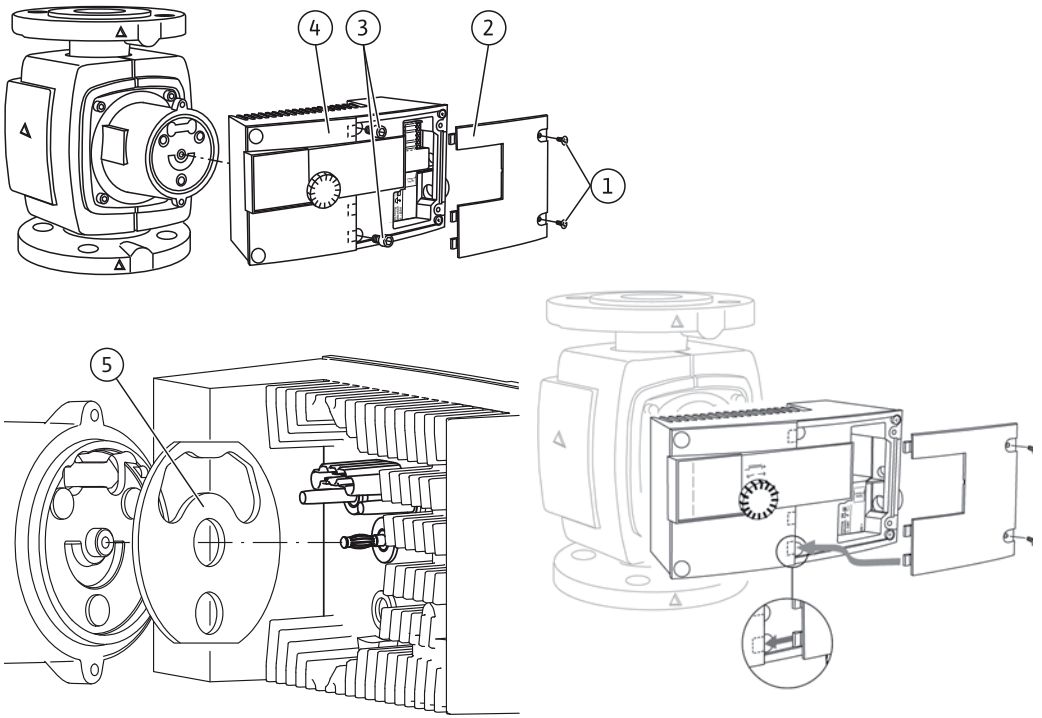

Fig. 5:

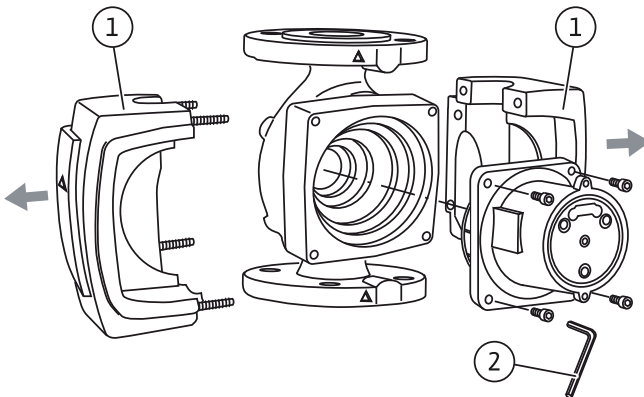

Fig. 6:

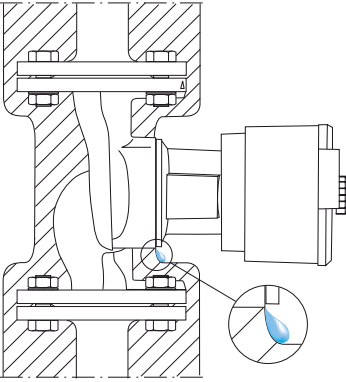

Fig. 7:

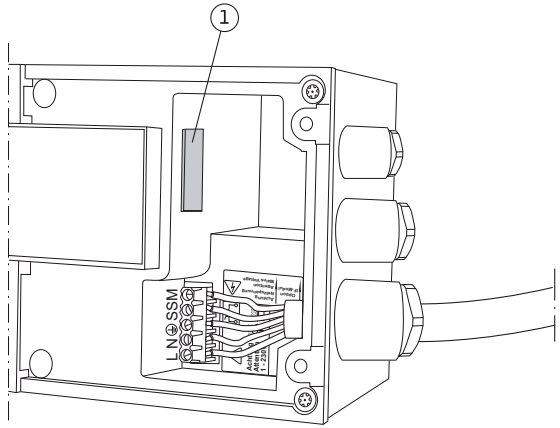

Fig. 8:

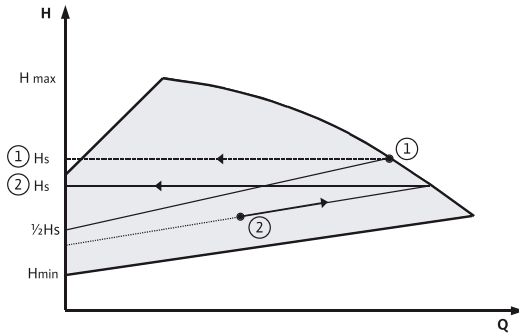

Fig. 9:

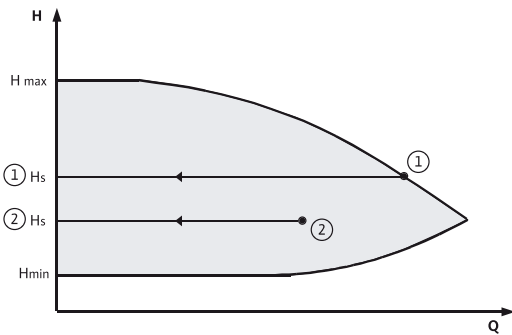

Fig. 10:

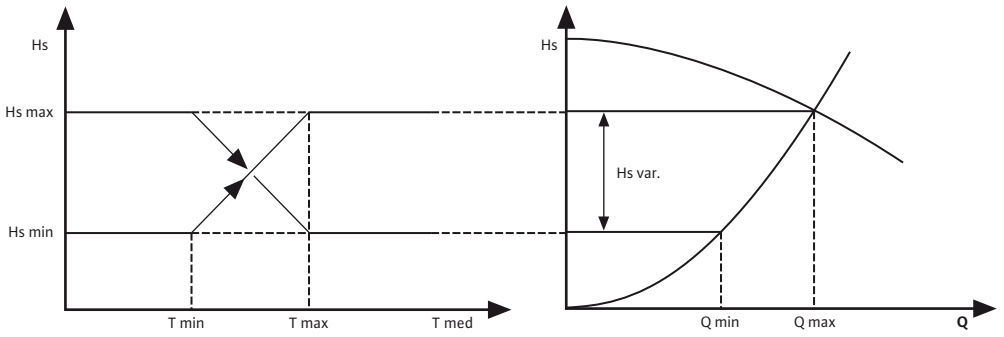

Fig. 11:

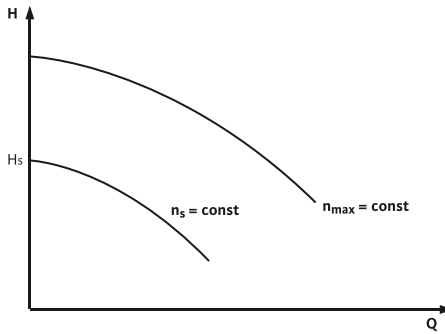

Table of contents	Page
1 General information	50
2 Safety	50
2.1 Indication of instructions in the operating instructions	50
2.2 Personnel qualifications	51
2.3 Danger in the event of non-observance of the safety instructions	51
2.4 Safety consciousness on the job	51
2.5 Safety instructions for the operator	52
2.6 Safety instructions for installation and maintenance work	52
2.7 Unauthorised modification and manufacture of spare parts	52
2.8 Improper use	52
3 Transport and interim storage	53
4 Intended use	53
5 Product information	54
5.1 Type key	54
5.2 Technical data	54
5.3 Scope of delivery	56
5.4 Accessories	56
6 Description and function	57
6.1 Description of the pump	57
6.2 Operation of the pump	57
6.2.1 Operating modes	57
6.2.2 Differential pressure control modes	58
6.2.3 Further operating modes for saving energy	59
6.2.4 General functions of the pump	59
6.2.5 Dual pump operation	60
6.2.6 Definition of the symbols on the LC display	61
7 Installation and electrical connection	63
7.1 Installation	63
7.1.1 Installing a threaded pipe union pump	64
7.1.2 Installing a flanged pump	65
7.1.3 Insulation of the pump in heating systems	66
7.1.4 Insulation of the pump in cooling/air-conditioning systems	66
7.2 Electrical connection	67
8 Commissioning	70
8.1 Filling and venting	70
8.2 Setting the menu	70
8.2.1 Using the control button	70
8.2.2 Switchover of the display	71
8.2.3 Settings in the menu	72
8.3 Selecting the control mode	81
8.4 Setting the pump performance	83
8.5 Operation	84
8.6 Decommissioning	84

9	Maintenance	84
9.1	Dismantling / installation	85
9.2	Dismantling / installation of the control module	86
10	Faults, causes and remedies	87
10.1	Fault signals – Heating/ventilation HV operating mode	87
10.2	Fault signals – Air-conditioning AC operating mode	87
10.3	Warning signals	89
11	Spare parts	92
12	Disposal	93

1 General

About this document

The language of the original operating instructions is German. All other languages of these instructions are translations of the original operating instructions.

These installation and operating instructions are an integral part of the product. They must be kept readily available at the place where the product is installed. Strict adherence to these instructions is a precondition for the proper use and correct operation of the product.

These installation and operating instructions correspond to the relevant version of the product and the underlying safety standards valid at the time of going to print.

EC declaration of conformity:

A copy of the EC declaration of conformity is a component of these operating instructions.

If a technical modification is made on the designs named there without our agreement, this declaration loses its validity.

2 Safety

These operating instructions contain basic information which must be adhered to during installation, operation and maintenance. For this reason, these operating instructions must, without fail be read by the service technician and the responsible specialist/operator before installation and commissioning.

It is not only the general safety instructions listed under the main point "safety" that must be adhered to but also the special safety instructions with danger symbols included under the following main points.

2.1 Indication of instructions in the operating instructions

Symbols:

General danger symbol



Danger due to electrical voltage



NOTE:



Signal words:

DANGER!

Acutely dangerous situation.

Non-observance results in death or the most serious of injuries.

WARNING!

The user can suffer (serious) injuries. 'Warning' implies that (serious) injury to persons is probable if this information is disregarded.

CAUTION!

There is a risk of damaging the product/unit. 'Caution' implies that damage to the product is likely if this information is disregarded.

NOTE:

Useful information on handling the product. It draws attention to possible problems.

Information applied directly to the product, such as:

- direction of rotation arrow,
- identifiers for connections,
- name plate,
- and warning sticker,

must be strictly complied with and kept in legible condition.

2.2 Personnel qualifications

The installation, operating and maintenance personnel must have the appropriate qualifications for this work. Area of responsibility, terms of reference and monitoring of the personnel are to be ensured by the operator. If the personnel are not in possession of the necessary knowledge, they are to be trained and instructed. This can be accomplished if necessary by the manufacturer of the product at the request of the operator.

2.3 Danger in the event of non-observance of the safety instructions

Non-observance of the safety instructions can result in risk of injury to persons and damage to the environment and the product/unit. Non-observance of the safety instructions results in the loss of any claims to damages.

In detail, non-observance can, for example, result in the following risks:

- danger to persons from electrical, mechanical and bacteriological influences,
- damage to the environment due to leakage of hazardous materials,
- damage to property,
- failure of important product/unit functions,
- failure of required maintenance and repair procedures.

2.4 Safety consciousness on the job

The safety instructions included in these installation and operating instructions, the existing national regulations for accident prevention together with any internal working, operating and safety regulations of the operator are to be complied with.

2.5 Safety instructions for the operator

This appliance is not intended for use by persons (including children) with reduced physical, sensory or mental capabilities, or lack of experience and knowledge, unless they have been given supervision or instruction concerning use of the appliance by a person responsible for their safety.

Children should be supervised to ensure that they do not play with the appliance.

- If hot or cold components on the product/the unit lead to hazards, local measures must be taken to guard them against touching.
- Guards protecting against touching moving components (such as the coupling) must not be removed whilst the product is in operation.
- Leakages (e.g. from a shaft seal) of hazardous (e.g. explosive, toxic or hot) fluids must be discharged so that no danger to persons or to the environment arises. National statutory provisions are to be complied with.
- Highly flammable materials are always to be kept at a safe distance from the product.
- Danger from electrical current must be eliminated. Local directives or general directives [e.g. IEC, VDE etc.] and local energy supply companies must be adhered to.

2.6 Safety instructions for installation and maintenance work

The operator must ensure that all installation and maintenance work is carried out by authorised and qualified personnel, who are sufficiently informed by their own detailed study of the operating instructions.

Work to the product/unit may only be carried out when at a standstill. It is mandatory that the procedure described in the installation and operating instructions for shutting down the product/unit be complied with.

Immediately on conclusion of the work, all safety and protective devices must be put back in position and/or recommissioned.

2.7 Unauthorised modification and manufacture of spare parts

Unauthorised modification and manufacture of spare parts will impair the safety of the product/personnel and will make void the manufacturer's declarations regarding safety.

Modifications to the product are only permissible after consultation with the manufacturer. Original spare parts and accessories authorised by the manufacturer ensure safety. The use of other parts will absolve us of liability for consequential events.

2.8 Improper use

The operating safety of the supplied product is only guaranteed for conventional use in accordance with Section 4 of the operating instructions. The limit values must on no account fall under or exceed those specified in the catalogue/data sheet.

3 Transport and interim storage

On arrival, immediately check the product and its packaging for damage caused during transit. If damage is found, the necessary procedure involving the forwarding agent must be taken within the specified period.



CAUTION! Risk of injuries to personnel and damage to property!

Incorrect transport and interim storage can cause damage to the product and injury to personnel.

- **The pump and its packaging must be protected against moisture, frost and mechanical damage during transport and interim storage.**
- **Packaging that has become weakened due to moisture may allow the product to fall out, causing injury to personnel.**
- **When the pump needs to be transported, it may be carried only by the motor/pump housing. Never carry it by the module/terminal box, cable or external capacitor.**

4 Intended use

The high-efficiency pumps of the Wilo-Stratos/-D/-Z/-ZD series are used to circulate fluids (no oil or fluids containing oil, no foodstuffs) in:

- hot water heating systems
- cooling and cold water circuits
- closed-circuit industrial circulation systems
- solar installations



WARNING! Health hazard!

Due to the materials used, the pumps of the Wilo-Stratos/-D series may not be used for potable water or food applications.

The pumps of the Wilo-Stratos-Z/-ZD series are also suitable for use in:

- drinking water circulation systems

5 Product information

5.1 Type key

Example: Stratos-D 32/1-12	
Stratos	= high-efficiency pump
D	= single pump -D = double pump -Z = single pump for drinking water circulation systems -ZD= double pump for drinking water circulation systems
32	32 = flange connection nominal diameter of 32 Threaded connection: 25 (Rp 1), 30 (Rp 1¼) Flange connection: DN 32, 40, 50, 65, 80, 100 Combination flange(PN 6/10): DN 32, 40, 50, 65
1-12	1 = lowest selectable delivery head in [m] 12 = maximum delivery head in [m] at Q = 0 m ³ /h

5.2 Technical data	
Max. flow rate	Depends on the pump type, see catalogue
Max. delivery head	Depends on the pump type, see catalogue
Speed	Depends on the pump type, see catalogue
Mains voltage	1~230 V ±10% as per DIN IEC 60038
Frequency	50/60 Hz
Nominal current	see name plate
Insulation class	see name plate
Protection class	see name plate
Power consumption P ₁	see name plate
Nominal diameters	see type key
Connection flanges	see type key
Pump weight	Depends on the pump type, see catalogue
Permissible ambient temperature	-10°C bis +40°C
Max. rel. humidity	≤ 95%
Permissible fluid temperature	For heating, ventilation and air-conditioning applications: -10°C to +110°C For drinking water circulation applications: up to 3.57 mmol/l (25°e): 0°C to +80°C
Max. permissible operating pressure	PN 6/10 ¹⁾ PN 16 ²⁾

5.2 Technical data

Approved fluids Wilo-Stratos/-D/-Z/-ZD	<p>Heating water (as per VDI 2035/VdTÜV Tch 1466) Water/glycol mixtures, max. mixing ratio of 1:1 (the delivery data of the pump should be corrected according to the higher viscosity, depending on the mixing ratio percentage, if glycol is added.) Only use brand-name goods with corrosion protection inhibitors; comply with the manufacturer's specifications and safety data sheets. The pump manufacturer's approval must be obtained for the use of other fluids. Ethylene/propylene glycol with corrosion inhibitors Commercially available oxygen binding agents ³⁾ Commercially available corrosion inhibitors ³⁾ Commercially available combination products ³⁾ Commercially available cooling brines ³⁾</p>
Wilo-Stratos-Z/-ZD	Potable water and water for foodstuff applications as per EC drinking water directive.
Emission sound-pressure level	< 54 dB(A) (depending on the pump type)
EMC (electromagnetic compatibility)	General EMC: EN 61800-3
Emitted interference	EN 61000-6-3
Interference resistance	EN 61000-6-2
Residual current ΔI	$\leq 3,5$ mA (see also chapter 7.2)

¹⁾ Standard version

²⁾ Special version or supplementary equipment (additional charge)

³⁾ See following warning



CAUTION! Risk of injury and damage to property!

Non-approved fluids can damage the pump and also cause injury.

Comply strictly with the relevant safety data sheets and manufacturer's data!

- ³⁾ **Observe the specifications of the manufacturer regarding the mixing ratios.**
- ³⁾ **Add additives to the fluid on the pressure side of the pump.**

Minimum inlet pressure (above atmospheric pressure) at the pump suction port in order to avoid cavitation noises (at fluid temperature T_{Med}):

Nominal diameter	T_{Med}	T_{Med}	T_{Med}
	-10°C...+50°C	+95°C	+110°C
Rp 1	0.3 bar	1.0 bar	1.6 bar
Rp 1¼	0.3 bar	1.0 bar	1.6 bar
DN 32	0.3 bar	1.0 bar	1.6 bar
DN 40 ($H_{max} \leq 10$ m)	0.3 bar	1.0 bar	1.6 bar
DN 40	0.5 bar	1.2 bar	1.8 bar
DN 50 ($H_{max} \leq 10$ m)	0.3 bar	1.0 bar	1.6 bar
DN 50	0.5 bar	1.2 bar	1.8 bar
DN 65 ($H_{max} \leq 9$ m)	0.5 bar	1.2 bar	1.8 bar
DN 65	0.7 bar	1.5 bar	2.3 bar
DN 80	0.7 bar	1.5 bar	2.3 bar
DN 100	0.7 bar	1.5 bar	2.3 bar

The values apply up to 300 m above sea level; allowance for higher altitudes: 0.01 bar/100 m increase in height.

5.3 Scope of delivery

- Pump, complete
 - Two gaskets for threaded connection
 - Two-piece thermal insulation shell (single pump only, Fig. 1a, item 3)
 - Material: EPP, polypropylene foam
 - Thermal conductivity: 0.04 W/m as per DIN 52612
 - Flammability: B2 class as per DIN 4102, FMVSS 302
 - Eight M12 washers
(for M12 flange bolts for DN32–DN65 combination flanged version)
 - Eight M16 washers
(for M16 flange bolts for DN32–DN65 combination flanged version)
 - Installation and operating instructions

5.4 Accessories

Accessories must be ordered separately:

- IF Modules
- IR operating and service units (IR-Monitor/IR-Module /IR-Stick)
See catalogue for detailed list.

6 Description and function

6.1 Description of the pump

The high-efficiency pumps Wilo-Stratos are glandless pumps with integrated differential pressure control and ECM technology (**E**lectronic **C**ommutated **M**otor). The pump can be installed as **single** (Fig. 1a) or **double pump** (Fig. 1b).

- 1 Control module
 - 1.1 Infrared interface
 - 1.2 LC display
 - 1.3 Control button
- 2 Pump housing
- 3 Thermal insulation

6.2 Function of the pump

There is a **control module** (Fig. 1a, item 1) in axial design on the motor housing, which controls the differential pressure of the pump to a setpoint within the control range. Depending on the control mode, the differential pressure follows different criteria. In all control modes, however, the pump adapts itself continuously to the changing power requirements of the unit, which is the case especially when thermostatic valves, zone valves or mixers are used.

The main advantages of the electronic control are the following:

- Energy savings and hence reduction of the operating costs,
- Reduction of flow noises,
- Reduction of the number of differential pressure valves required.

The high-efficiency pumps of the Wilo-Stratos-Z/-ZD series are specially adapted to the operating conditions in drinking water circulation systems due to the choice of material and design.

If pumps of the Wilo-Stratos-Z/-ZD series in grey cast iron version (pump housing made of grey cast iron) are used in drinking water circulation systems, the national regulations and guidelines should be complied with as applicable.

6.2.1 Operating modes

The Stratos series can be operated in "Heating" or "Cooling/air-conditioning" operating modes. The two operating modes are distinguished from one another in terms of their tolerance for faults in the handling of fault signals that occur.

"Heating" operating mode:

Faults are handled in a tolerant fashion (as is normally the case), e.g. depending on the type of fault, the pump does not indicate a fault until the same fault has occurred repeatedly within a particular period. See Chapter 10.1 and flow diagram - fault / warning signal during **"HV operation"**.

"Cooling/air-conditioning" operating mode:

For all applications for which each fault (in the pump or the system) needs to be detected quickly (e.g. air-conditioning applications).

Each fault, with the exception of the E10 fault (blocking) is indicated immediately (< 2 sec.). In the event of blocking (E10), various restart attempts will be carried out, which means that in such cases no fault signal will occur until after a maximum of 40 sec.

See Chapter 10.2 and flow diagram – fault / warning signal during

"AC operation".

Both operating modes distinguish between faults and warnings. In the event of a fault, the motor is switched off, the fault code is displayed on the monitor and the fault is indicated by the red LED.

Faults always result in the activation of the SSM ("collective fault signal" via a relay).

In the case of dual pump management (double pump or 2x single pumps), the standby pump starts within the time period specified below following the occurrence of the fault.

Stratos, Stratos-D, Stratos-Z, Stratos-ZD	Starting time
25/1-4, 25/1-6, 25/1-8, 30/1-4, 30/1-6, 30/1-8, 32/1-8, 40/1-4	approx. 9 sec.
25/1-10, 30/1-10, 32/1-10, 40/1-10, 50/1-10, 80/1-12, 100/1-12	approx. 7 sec.
40/1-12, 50/1-9, 50/1-12, 65/1-9	approx. 4 sec.
30/1-12, 32/1-12, 40/1-8, 50/1-8, 65/1-12	approx. 3 sec.

6.2.2 Differential pressure control modes

- **Δp-v:** The electronics change the differential pressure setpoint to be maintained by the pump in linear form between $\frac{1}{2}H_S$ and H_S . The differential pressure setpoint H falls or increases with the flow rate (Fig. 8), factory setting.
- **Δp-c:** The electronics maintain the differential pressure created by the pump above the permitted flow range constantly at the selected differential pressure setpoint H_S up to the maximum pump curve (Fig. 9).
- **Δp-T:** The electronics change the differential pressure setpoint to be maintained by the pump according to the measured fluid temperature. This control mode can only be selected with an IR operating and service unit (accessory) or via PLR/LON/CAN/Modbus/BACnet. Two settings are possible (Fig. 10):
 - Control with positive increase:
If the temperature of the fluid is increased, the differential pressure setpoint is increased in linear form between H_{Smin} and H_{Smax} (setting: $H_{Smax} > H_{Smin}$).
 - Control with negative increase:
If the temperature of the fluid is increased, the differential pressure setpoint is reduced in linear form between H_{Smin} and H_{Smax} (setting: $H_{Smax} < H_{Smin}$).

6.2.3 Further operating modes for saving energy

- **Manual control mode:** The speed of the pump is maintained at a constant speed between n_{\min} and n_{\max} (Fig. 11). Manual control mode deactivates differential pressure control at the module.
- If "**auto**" operating mode is activated, the pump is able to detect minimum heating output requirements of the system by the prolonged reduction of the fluid temperature and then switching over to **setback operation**. If heating output requirements are increased, the unit automatically switches over to control mode. This setting ensures that the pump's power consumption is reduced to a minimum, which is the ideal setting in most cases.



CAUTION! Risk of damage to property!

Setback operation may only be enabled if hydraulic balancing of the system was performed. In the event of non-compliance, insufficiently supplied system components may freeze up in the event of frost.

6.2.4 General functions of the pump

- The pump is equipped with an electronic **overload protection** function which switches off the pump in the event of an overload.
- For **data storage**, the control module is equipped with a non-fading memory. All settings and data are retained no matter how longer the module is disconnected from the power supply. When the power supply is re-established, the pump continues to run with the values set prior to disconnection from the power supply.
- **Pump kick:** Any pumps switched off via the (ON/OFF) menu, a bus command, the infrared interface, the Ext.Off control input or 0-10V start running for a short time every 24 hours to prevent blockages in the event of long standstill periods. The mains voltage must not be interrupted for this function. If disconnection from the mains is planned for a lengthy period, the pump kick must be applied by the heating/boiler control by switching on the mains voltage briefly. For this, the pump must be switched on by the control prior to disconnection from the mains (display → motor/module symbol lights up).
- **SSM:** The contact of the collective fault signal (potential-free normally closed contact) can be connected to a building automation system. The internal contact is closed if the pump is without power, if there is no fault or if there is a malfunction of the control module. The performance of the SSM is described in Chapters 6.2.5, 10.1 and 10.2.
- For connecting to external monitoring units, the system can be expanded by retrofitting interface modules for communication. Analogue and digital IF Modules are available as an option (see catalogue).

6.2.5 Dual pump operation

Double pumps or two single pumps (installed in parallel) can be retrofitted with an integrated dual pump management system.

- **IF-Modules Stratos:** For communication between pumps, an IF Module is installed in the control module of each pump. These IF Modules are connected to each other via the DP interface.
This dual pump management has the following functions:
- **Master/slave:** Both pumps are controlled by the master. All settings are made at the master.
- **Main/standby mode:** Each of the two pumps provides the configured flow rate. The other pump is available in case of a malfunction or runs after pump cycling. Always only one pump runs. Main/standby mode is also fully active with two single pumps of the same type in one double pump installation.
- **Efficiency-optimised peak-load operation:** In the partial load range, the hydraulic output is provided at the beginning by one pump. The second pump is then also connected for efficiency optimisation if the total power consumption P_1 of both pumps is less than the power consumption P_1 of one pump. Both pumps are then simultaneously adjusted upwards to the maximum speed. This operating mode (load-sensitive activation/deactivation) achieves additional energy savings compared to conventional peak-load operation. Parallel operation of two single pumps is only possible for pumps for which there is an equivalent double pump type.
- If one of the pumps has a **breakdown/fault**, the other pump runs as single pump in the operating modes specified by the master. The reaction in the event of a fault depends on whether HV or AC operating mode is active (see Chapter 6.2.1).
- In the event of a **communication failure** (e.g. due to the power supply failing at the master pump): After 5 seconds the slave starts and runs according to the last specification of the operating modes by the master pump.
- **Pump cycling:** If only one pump is running (in main/standby, peak load or set-back operation), pump cycling takes place after every 24 hours of effective running time. Both pumps run at the time of pump cycling in order to ensure that operation is not interrupted.



NOTE: Both pumps always run if both manual control mode and synchronous mode are active at the same time. No pump cycling takes place.









No pump cycling takes place during active night reduction after 24 h of effective running time.









- **SSM:** The contact of the collective fault signal (SSM) can be connected to a central control centre.
SSM contact is only assigned at the master pump: Only the faults of the master are indicated ("SSM single" factory setting). If the faults are to be indicated by both master and slave pumps, an IR operating and service unit (accessory) must be used to program the SSM function at the master pump to "SSM combined" (see Installation and operating instructions for IR-Monitor/IR-Module/IR-

Stick). The signal then applies to the entire unit. Exception, in the event of a power failure of the master pump.

SSM contact is assigned at master and slave pumps: Any fault at master or slave pumps will be indicated as individual fault signal.

6.2.6 Definition of the symbols on the LC display

Symbol	Meaning
 auto	Automatic switchover to setback operation is enabled. Activation of setback operation takes place at minimum heating output requirement.
 auto	Pump runs in setback operation (night reduction) at min. speed.
(without Symbol)	Automatic switchover to setback operation disabled, i.e. pump runs solely in control mode.
	Setback operation activated via serial digital interface or "Ext.Min", regardless of the system temperature.
	Pump runs in warm-up mode at max. speed. The setting can only be activated via the serial digital interface.
	Pump is switched on.
OFF 	Pump is switched off.
H 5,0 _m	Differential pressure setpoint is set to H = 5.0 m.
	Δp -v control mode, control to variable differential pressure setpoint (Fig. 8).
	Δp -c control mode, control to constant differential pressure setpoint (Fig. 9).
	Manual control mode deactivates the control in the module. The pump's speed is maintained at a constant value (Fig.11). The speed is set using the control button or via the bus interface.
26,0 ^{RPM} _{x100}	The pump is set to a constant speed (2.600 rpm in this case) (manual control mode).

Symbol	Meaning
10V	In manual control mode, the speed or nominal delivery head of Δp -c or Δp -v operating mode of the pump is set via the 0-10 V input of the IF Modules Stratos Ext.Off, Ext.Min and SBM. In this case, the control button is without function for entering the setpoint.
	Δp -T control mode, control to temperature-dependent differential pressure setpoint (Fig. 10). The current H_5 setpoint is displayed. This control mode can only be activated using an IR operating and service unit (accessory) or via the serial digital interface.
	All settings at the module are disabled apart from fault acknowledgement. Disabling is performed by the IR operating and service unit (accessory). Adjustments and enabling can only be made using IR operating and service units (accessories).
	The pump is operated via a serial data interface. The "On/Off" function is not activated at the module. Only  ,  , display position and fault acknowledgement need to be set at the module. The IR operating and service unit (accessory) can be used to temporarily interrupt operation at the interface (for checking, for reading out data). With certain IF Modules, the menu can be re-opened. (The menu can then still be operated manually even though the module is connected) (see documentation of the IF Modules)
SL	Pump is running as slave pump. No change can be made at the display.
	The double pump runs in efficiency-optimised peak load operation (master + slave).
	Double pump running in main/standby mode (master or slave)
Id	Appears on pumps with certain IF Modules (see documentation of IF Modules) if a signal (sign) is sent from the building management system to the pump.
	The pump is set in the "US units" mode.
HN	Fault-tolerant error matrix activated. Heating operating mode (for faults, see Chapter 10)
AC	Fault-tolerant error matrix deactivated. Air-conditioning operating mode (for faults, see Chapter 10)

Menu structure: There are three menu levels. The levels below the indication of the basic settings are always accessed from level 1 by pressing the control button for different lengths of time.

- **Level 1 – Status indication** (indication of the operating status)
- **Level 2 – Operation menu** (setting the basic functions):
 - Press the control button for longer than 1 second
- **Level 3 – Options menu** (further settings):
 - Press the control button for longer than 6 seconds



NOTE: After 30 s without any entry being made, the display jumps back to level 1 (indication of the operating status). Temporary, non-acknowledged modifications are discarded.

7 Installation and electrical connection



DANGER! Risk of fatal injury!

Incorrect installation and inexpert electrical connection can pose a risk of fatal injury. Danger from electrical current must be ruled out.

- **Installation and electrical connection may only be carried out by qualified personnel and in accordance with the applicable regulations!**
- **Accident prevention regulations must be observed!**
- **Comply with the regulations of the local power supply company!**
- **Pumps with pre-assembled cable:**
 - **Never pull on the pump cable**
 - **Do not kink the cable.**
 - **Do not place any objects on the cable**

7.1 Installation



WARNING! Risk of injury!

Incorrect installation can result in injuries.

- **There is a crushing hazard**
- **There is a risk of injury due to sharp edges/burrs. Wear appropriate protective clothing (e.g. safety gloves)!**
- **There is a risk of injury hazard due to the pump/motor falling. Use suitable lifting gear to secure the pump/motor against falling.**



CAUTION! Risk of damage to property!

Incorrect installation can result in damage to property.

- **Have installation work performed by qualified personnel only!**
- **Observe national and regional regulations!**
- **When the pump needs to be transported, it may be carried only by the motor/pump housing. Never at the module/terminal box or pre-assembled cable.**
- **Installation within a building:**
 - **Install the pump in a dry, well-ventilated and frost-free room.**

- Installation outside a building (outdoor installation):
 - Install the pump in a sump (e.g. light sump, annular sump) with cover or in a cabinet/housing as weather protection.
 - Avoid exposure of the pump to direct sunlight.
 - The pump requires protection so that the condensate drain grooves are not contaminated. (Fig. 6)
 - Protection of the pump against rain. Dripping water from above is permitted provided that the electrical connection has been established in accordance with the installation and operating instructions and the terminal box has been properly sealed.



CAUTION! Risk of damage to property!

Ensure sufficient ventilation/heating if the ambient temperature exceeds/falls below the permitted limit values.

- Carry out all welding and soldering work prior to the installation of the pump



CAUTION! Risk of damage to property!

Contamination from the pipe system can destroy the pump during operation. Before installing the pump, flush the pipe system.

- Provide check valves upstream and downstream of the pump.
- Attach pipework to the floor, ceiling or wall using appropriate fittings so that the pump does not bear the weight of the pipework.
- If installed in the feed pipe to an open system, the safety feed pipe must branch off at the pump's discharge side.
- Remove the two half shells of the thermal insulation (Fig. 5, item 1) before installing the single pump.
- Install the pump at an easily accessible point so that it can be easily checked or replaced at a later time.
- Precautions during installation:
 - Perform assembly so that the pump shaft is horizontal and not under strain (see the installation positions shown in Fig. 2a/2b).
 - Make sure that it is possible to install the pump with the correct flow direction (cf. Fig. 2a/2b). Observe the direction triangle on the pump housing (Fig. 1a; item 2).
 - Make sure that it is possible to install the pump in the permitted installation position (cf. Fig. 2a/2b). If required, turn the motor including control module, see Chapter 9.1.

7.1.1 Installing a threaded pipe union pump

- Install appropriate threaded pipe unions before installing the pump.
- Use the supplied flat gaskets between the suction/pressure ports and threaded pipe unions when installing the pump.
- Screw union nuts onto the threads of the suction/pressure ports and tighten them using a suitable open-end wrench or pipe wrench.



CAUTION! Risk of damage to property!

Do not hold the pump by the motor/module when tightening the screwed connections. Apply the wrench surfaces to the suction/pressure port instead.

Pump type	Width across flats [mm]	
	Suction port	Pressure port
Stratos 25/1-4(6, 8, 10)	36	36
Stratos 30/1-4(6, 8, 10)	36	36
Stratos 30/1-12	41	41

- Check the threaded pipe unions for leaks.

7.1.2 Installing a flanged pump

Installation of pumps with combination flange PN6/10 (flange-end pumps from DN32 up to and including DN 65) and flange-end pumps DN80/DN100.



WARNING! Risk of injury and damage to property!

The flange connection can be damaged and develop leaks if the pump is not installed correctly. There is a risk of injury and damage to property due to hot fluid escaping.

- Never connect two combination flanges to each other!
- Pumps with combination flanges are not suitable for operating pressures PN16.
- The use of securing elements (e.g. spring rings) can result in leaks at the flange connection. They are therefore not permitted. The washers supplied (Fig. 3, item 1) must be inserted between screw heads / nut heads and the combination flange.
- The permissible tightening torques listed in the table below must not be exceeded, even if screws of higher strength (≥ 4.6) are used, since otherwise splintering can occur at the edges of the long holes. This causes the screws to lose their preload and the flange connection can become leaky.
- Use screws of sufficient length. The screw thread must protrude at least one thread turn beyond the nut (Fig. 3, item 2).

DN 32, 40, 50, 65	Nominal pressure PN6	Nominal pressure PN10/16
Screw diameter	M12	M16
Strength class	4.6 or higher	4.6 or higher
Permitted tightening torque	40 Nm	95 Nm
Min. screw length for		
• DN32/DN40	55 mm	60 mm
• DN50/DN65	60 mm	65 mm

DN 80, 100	Nominal pressure PN6	Nominal pressure PN10/16
Screw diameter	M16	M16
Strength class	4.6 or higher	4.6 or higher
Permitted tightening torque	95 Nm	95 Nm
Min. screw length for		
• DN80	65 mm	65 mm
• DN100	70 mm	70 mm

- Install appropriate flat gaskets between pump and counter flanges.
- Tighten the flange bolts crosswise in two steps to the prescribed tightening torque (see Table 7.1.2).
 - Step 1: 0.5 x permissible tightening torque
 - Step 2: 1.0 x permissible tightening torque
- Check the flange connections for leaks.

7.1.3 Insulation of the pump in heating systems

Fit the two half-shells of the thermal insulation before commissioning and push them together so that the guide pins engage in the opposite holes.



WARNING! Risk of burns!

The entire pump can become very hot. When retrofitting the insulation during normal operation there is a risk of burns.

7.1.4 Insulation of the pump in cooling/air-conditioning systems

- The thermal insulation shells (Fig. 5, item 1) included in the scope of delivery may only be used in heating/drinking water circulation applications at fluid temperatures of +20°C or higher, since these thermal insulation shells do not enclose the pump housing in a diffusion-proof manner.
- For applications in cooling and air-conditioning systems, commercially-available diffusion-proof thermal insulation materials must be used.



CAUTION! Risk of damage to property!

If the diffusion-proof insulation is fitted at the site, the pump housing may only be insulated up to the motor flange. The condensate drain holes must remain unobstructed to ensure that condensate that develops in the motor can drain without problems (Fig. 6). Condensate that accumulates in the motor can cause an electrical defect.

7.2 Electrical connection



DANGER! Risk of fatal injury!



Improper electrical connections pose a risk of fatal injury due to electric shock.

- Only allow the electrical connection to be made by an electrician approved by the local power supply company and in accordance with the local regulations in force.
- Before working on the pump, all poles of the power supply must be disconnected. Work on the module may only be started once 5 minutes have passed, due to the dangerous residual contact voltage.
- Check to ensure that all connections (including potential-free contacts) are voltage-free.



CAUTION! Risk of damage to property!

An incorrect electrical connection can cause damage to property.

- If the wrong voltage is applied, the motor can be damaged!
- Control via triacs / semi-conductor relays must be checked in individual cases, since the electronics can be damaged!
- The current type and voltage of the mains connection must correspond to the specifications on the name plate.
- The electrical connection must be established via a fixed power cable (3 x 1.5 mm² minimal cross-section), equipped with a plug and socket connector or an all-pole switch with a minimum contact opening width of 3 mm.
- The following minimum requirements are to be met if shutdown takes place by means of an onsite network relay:
 - nominal current ≥ 10 A, nominal voltage 250 VAC
- Fuse protection: 10/16 A, slow-blow or automatic fuse with C characteristic
 - **Double pumps:** provide a separate mains connection cable and a separate fuse on the mains side for both motors of the double pump.
- A motor protection switch supplied by the customer is not required. Nevertheless, if such a protection switch is available in the installation, it must be bypassed or set to the highest possible current.
- It is recommended to safeguard the pump with a residual-current-operated protection switch. Labeling: FI -  or  

When dimensioning the residual-current-operated protection switch, take the number of pumps connected and their nominal motor currents into account.
- Leakage current per pump $I_{\text{eff}} \leq 3.5$ mA (as per EN 60335)
- When pumps are used in systems with water temperatures above 90°C, a suitable heat-resistant supply cable must be used.
- All connection cables must be installed so that they do not touch the pipe and/or the pumps or motor housing.

- In order to ensure drip protection and strain relief on the threaded cable connection, cables with a sufficient outer diameter (see Table 7.2) must be used and must be screwed sufficiently tightly. In addition, the cables near the screwed connection are to be bent to form a drainage loop, to drain any accumulated drips. Unused threaded cable connections should be blanked off with the sealing plates provided, and screwed tight.



DANGER! Risk of fatal electrical shock!

There may be dangerous contact voltage at the contacts of the IF Module interface.

If no IF Module (accessory) is plugged into the module compartment, the stopper (Fig. 7, item 1) must cover the IF Module interface so that it cannot be touched. Make sure that it is seated correctly.

- Commission pumps only if they are fitted with the correct modular cover. Check that the cover seal is correctly seated.



WARNING! Risk of injury and damage to property!

If the fan cover is damaged, the protection class and electrical safety are not ensured. Check the seat of the fan cover.

- **Assignment of the threaded cable connections:**

The following table shows the possible combinations of electric circuits in a cable for assigning the individual threaded cable connections. DIN EN 60204-1 (VDE 0113, sheet 1) must be complied with:

- Clause 14.1.3 as follows: Conductors of different electric circuits may belong to the same multi-conductor cable if the highest voltage which may occur in the cable is insulated sufficiently.
- Clause 4.4.2 as follows: Signal lines with low levels should be separated from power lines if there is a potential risk of functional interference due to EMC.

Screwed connection:		PG 13.5	PG 9	PG 7
	Cable cross-section:	8...10 mm	6...8 mm	5...7 mm
1.	Function	Mains line SSM		DP management
	Cable type	5x1.5 mm ²		Two-wire cable (l ≤ 2.5 m)
2.	Function	Mains line	SSM	DP management
	Cable type	3x1.5 mm ² 3x2.5 mm ²	Two-wire cable	Two-wire cable (l ≤ 2.5 m)

Screwed connection:		PG 13.5	PG 9	PG 7
3.	Function	Mains line	SSM/0...10V/Ext.Off or SSM/0...10V/Ext.Min or SSM/SBM/0...10V or SSM/SBM/Ext.Off	DP management
	Cable type	3x1.5 mm ² 3x2.5 mm ²	Multi-wire control cable, number of wires according to number of control circuits, shielded if necessary	Two-wire cable (l ≤ 2.5 m)
4.	Function	Mains line	Serial digital interface	DP management
	Cable type	3x1.5 mm ² 3x2.5 mm ²	Bus cable	Two-wire cable (l ≤ 2.5 m)
5.	Function	Mains line	Serial digital interface	Serial digital interface
	Cable type	3x1.5 mm ² 3x2.5 mm ²	Bus cable	Bus cable

Table 7.2

**DANGER! Risk of fatal electrical shock!**

If the mains and SSM cores are both in the same 5-wire cable (Tab. 7.2, version 1), the SSM core may not be operated with protective low voltage, otherwise there could be voltage transmission.

- Earth the pump/unit according to regulations.
- **L, N, ** : mains connection voltage: 1~230 VAC, 50/60 Hz, DIN IEC 60038, alternatively, the mains connection between two phases of a three phase net earthed in a start point is possible with a triangular voltage of 3~230 VAC, 50/60 Hz.
- **SSM:** An integrated collective fault signal is applied at the SSM terminals as potential-free normally closed contact. Contact load:
 - Permitted minimum: 12 V DC, 10 mA
 - Permitted maximum: 250 V AC, 1 A
- **Switching frequency:**
 - Switch-on/off procedures via mains voltage ≤ 20 / 24 h
 - Switch-on/off procedures via Ext.Off, 0-10 V or via digital, serial interface ≤ 20 / h



NOTE: If an individual motor is switched voltage-free in a double pump, the integrated dual pump management is deactivated.

8 Commissioning

Do not fail to observe the danger information and warnings in Chapters 7, 8.5 and 9!

Prior to commissioning the pump, check that it was installed and connected correctly.

8.1 Filling and venting



NOTE: Incomplete venting will result in noises in the pump and unit.

Prime and vent the unit correctly. Venting the pump rotor compartment is carried out automatically after a short operating period. Dry running for short periods will not harm the pump.



WARNING! Risk of injury and damage to property!

It is not permitted to remove the motor head or the flange connection / threaded pipe union for the purpose of venting the system!

- **There is a risk of scalding!**
Escaping fluid can lead to injuries and damage to property.
- **Touching the pump can cause burns! Depending on the operating status of the pump or unit (fluid temperature), the entire pump can become very hot.**

8.2 Setting the menu



WARNING! Risk of burns!

Depending on the operating status of the system, the entire pump can become very hot. There is a risk of burns if metallic surfaces are touched (e.g. cooling fins, motor housing, pump housing).

The setting can be made on the control module during normal operation by pressing the control button. Do not touch any hot surfaces when doing this.

8.2.1 Using the control button (Fig. 1a, item 1.3)

- Starting with the basic setting, by pressing the button (for the 1st menu: pressing it longer than 1 second), the setting menus are selected in succession in a defined sequence. The corresponding symbol flashes. By turning the button to the left or right, the parameters can be changed backwards or forwards on the display. The newly set symbol flashes. The new setting is saved by pressing the button. Then, the next selection option appears.
- The basic setpoint setting (differential pressure or speed) is changed by turning the control button. The new value flashes. The new setpoint is saved by pressing the button.
- The old value is retained and the basic setting is displayed again if the new setting is not confirmed within 30 seconds.

8.2.2 Switchover of the display

- For the layout of the control module, whether in horizontal or vertical installation position, the position of the display can be adjusted, turned by 90°. The position setting can be defined in menu item 3. The display position specified by the basic setting is indicated by "ON" flashing (for horizontal installation position). The display can be changed by turning the adjustment button. "ON" flashes for the vertical installation position. Press the adjustment button to confirm the setting.

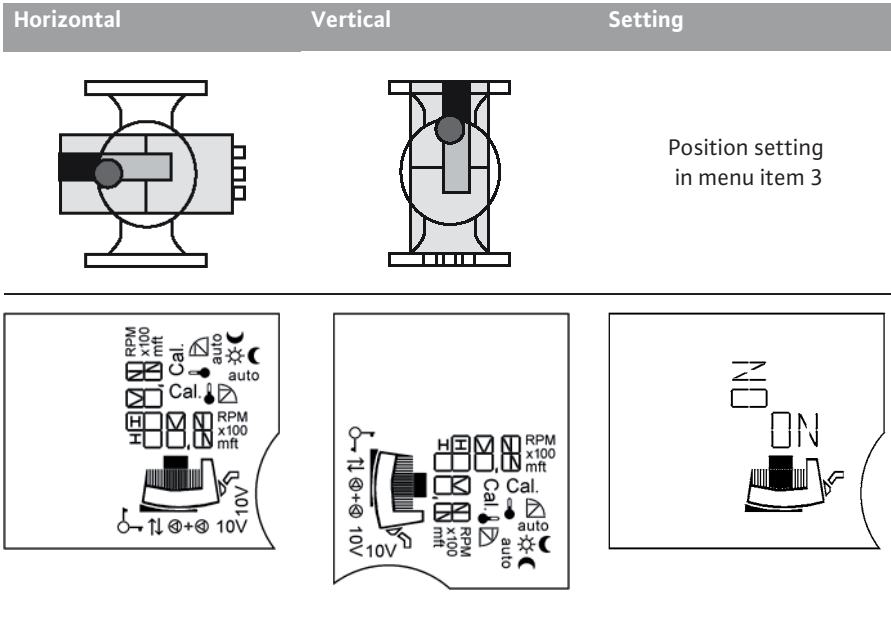







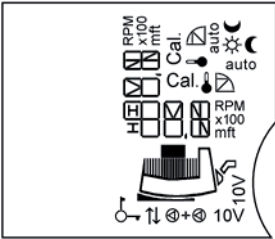
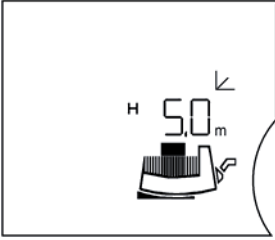

8.2.3 Settings in the menu

During operation of the single pump's display, the following menus appear in succession:

- **Single pump operation:**

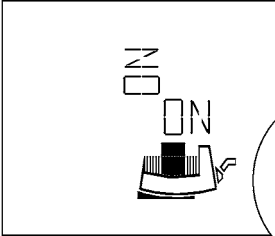
Setting during initial commissioning / menu sequence during normal operation
(horizontal display)

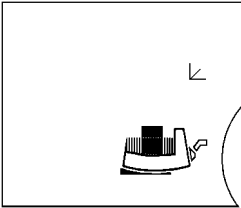
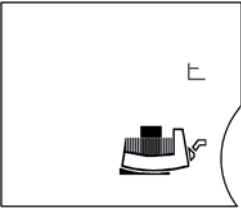
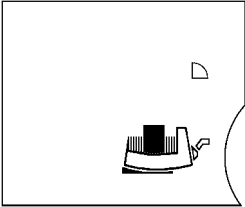
LC display	Setting
<p>①</p> 	<p>When the module is switched on, all symbols appear on the display for 2 s. Then, the current setting ② is applied.</p>
<p>②</p> 	<p>Current (basic) setting (factory setting):</p> <p>H 5,0 m</p> <ul style="list-style-type: none"> • e.g. nominal delivery head $H_s = 5.0$ m and $\frac{1}{2} H_{max}$ (factory setting depends on the pump type) • $\Delta p-v$ control mode • Pump runs in control mode, setback operation disabled (see also menu item ⑦). • missing = single pump <hr/> <p> Turn the control button to adjust the differential pressure setpoint. The new differential pressure setpoint flashes.</p> <hr/> <p> The new setting is saved by briefly pressing the button. The flashing differential pressure setpoint previously set is reset to the previous value if the button is not pressed within 30 seconds.</p> <hr/> <p> Press control button > 1 second. The next menu item ③ appears.</p>
<p>The basic setting is displayed again if no setting is made in the subsequent menu within 30 seconds ②.</p>	

LC display	Setting
<p>③</p> 	<p>Position setting of the display vertical / horizontal</p> <p>The position setting of the display is indicated by "ON" flashing.</p> <hr/> <p> The other position is selected by turning the control button.</p> <hr/> <p> The setting is applied.</p>
<p>④</p>   	<p>The control mode currently set flashes.</p> <hr/> <p> Turn the control button to select other control modes. The newly selected control mode flashes</p> <hr/> <p> The setting is applied and the next menu appears.</p>

LC display

Setting

⑤

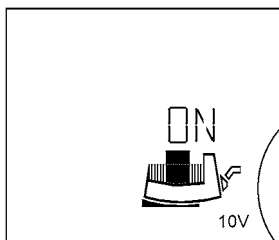

Menu item ⑤ appears only if an IF Module Stratos was plugged into the 0-10 V input

The "10V" symbol appears in the display

Switching 0-10V input on / off

Activating the 0-10V input:

The display indicates "ON" and the "module motor symbol".

The setpoint cannot be selected manually using the control button. "10V" is indicated in the basic setting ②.



The setting can be changed by turning the control button.

Deactivating the 0-10V input:

The display indicates "OFF".





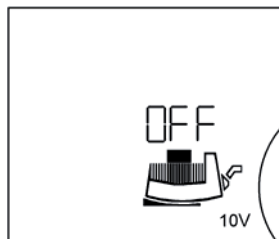





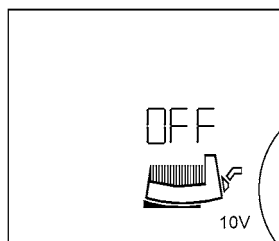

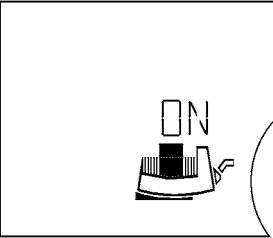
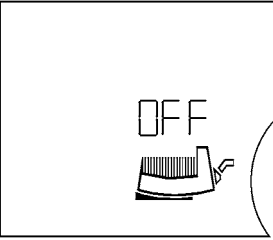
The setting is applied.

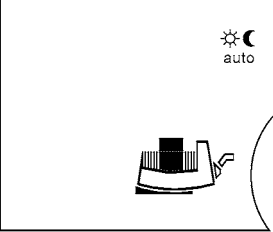



If the input was activated, the menu navigation jumps to menu item ⑦a.

If no input voltage is applied at the 0-10 V contact, "Off" appears on the display and the "motor symbol" is not displayed.





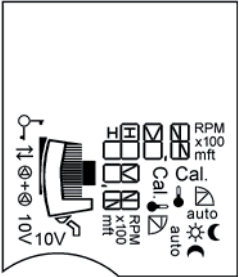
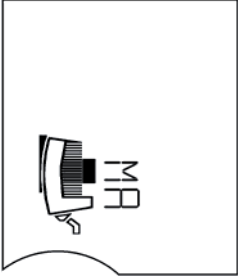
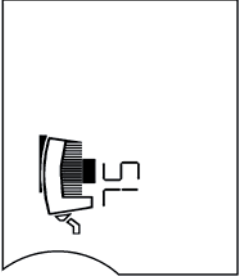



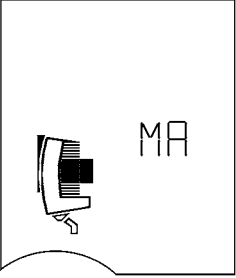

LC display	Setting
<p>⑥</p>  	<p>Switching the pump on /off</p> <p>Switching the pump on: The display indicates "ON" and the "motor motor symbol"</p> <hr/> <p> The setting can be changed by turning the control button.</p> <hr/> <p>Switching the pump off: The display indicates "OFF".</p> <hr/> <p> The setting is applied.</p> <hr/> <p>The "motor symbol" disappears when the pump is switched off.</p>
<p>⑦</p> 	<p>Enabling / disabling setback operation One of the following two symbols flashes:</p> <hr/> <p> normal control mode, setback operation disabled</p> <p> setback operation enabled:</p> <p> appears on the display in automatic control mode, or</p> <p> during setback operation</p> <hr/> <p> Turn the control button to select one of the two settings.</p> <hr/> <p> The setting is applied.  The next menu is displayed.</p> <hr/> <p>Menu item ⑦ is skipped if:</p> <ul style="list-style-type: none"> • Operation of the pump takes place with Stratos IF Modules, • Manual control mode was selected, • The 0...10V input was activated.
<p>⑦a</p> 	<p>In single pump mode, the display returns to the basic setting ②. In the event of a fault, ② the fault menu ⑩ is displayed before the basic setting. In dual pump mode, the display switches to menu ⑧.</p>

- **Dual pump operation:**
Adjustment during initial commissioning

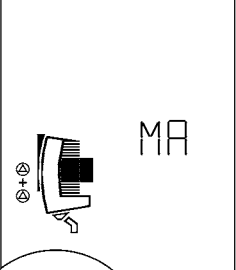
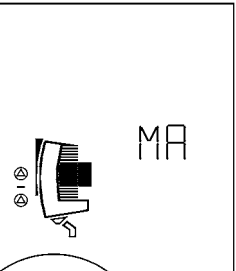







LC display	Setting
<p>①</p> 	<p>When the module is switched on, all symbols appear on the display for 2 seconds. Then menu ①a appears.</p>
<p>①a</p>  	<p>The symbol MA = master appears on the display of both pumps. If no setting is made, both pumps run at constant differential pressure ($H_s = \frac{1}{2} H_{max}$ at $Q = 0 \text{ m}^3/\text{h}$).</p> <p>By  on the control button of the left-hand pump, it is selected as the master pump and the operating mode setting menu ⑨ appears on the display. SL = slave appears automatically on the display of the right-hand pump.</p> <p>The definition: left-hand pump as master and right-hand pump as slave is thus selected. In this case, the rotary knob on the slave pump is no longer of significance. It cannot be used for settings.</p> <p>The display's position setting cannot be defined at the slave pump. The position setting at the slave pump is applied from the specification of the master pump.</p>

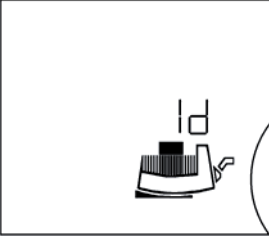

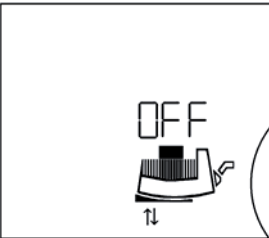
Dual pump operation: menu sequence during normal operation

When the module is switched on, all symbols ① appear on the display for 2 seconds. Then, the current setting ② is displayed. When you "scroll" on the MA display, the same menu sequence ②...⑦ is displayed as for the single pump. Then, the MA menu is displayed permanently.

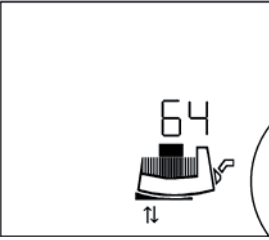

LC display	Setting
<p>⑧</p> 	<p>↻ on the MA indicates SL. If you  to confirm the SL, the other (right-hand) pump becomes the master pump. Master and slave have thus been swapped. Programming is now only possible on the right-hand (MA) pump. Adjustments cannot be made at the SL. It is only possible to swap master and slave pumps at the master pump.</p>
<p>⑨</p>  	<p>Setting Peak load or main / standby mode The current setting is displayed:</p> <hr/> <p> +  peak-load operation, or</p> <p>  main/standby operation</p> <hr/> <p>↻ Turning the control button results in the other setting lighting up.</p> <hr/> <p> The setting is applied</p> <hr/> <p>The display returns to the basic setting ②.</p>

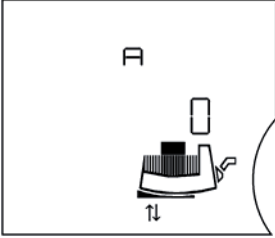
• Menu of IF Modules with bus function:

LC display	Setting
	<p>Signal for the building management system (BMS) "Id" (Identification number) appears on connected IF Modules with serial digital interface (not with PLR), for sending a signal to the building management system (for servicing or for commissioning the building automation (BA)).</p> <hr/> <p> If the control button is turned, the Id indicator flashes</p> <hr/> <p> The Id signal is sent to the building management system.</p> <hr/> <p>The display opens the next menu. If no signal is output, the control button can be turned until the Id indicator no longer flashes. Pressing the button opens the next menu on the display</p>
	<p>Setting the bus address "OFF": bus communication is switched off</p> <hr/> <p> appears on the display indicating communication via serial data interface.</p> <hr/> <p> Turn the control button to select a BUS address (e.g. 64). The address range depends on the bus system used (see corresponding Installation and operating instructions)</p> <hr/> <p> The setting is applied</p>
	<hr/> <p> The display opens the next menu</p>

LC display	Setting
 <p>The LC display shows the letter 'A' at the top. Below it is a diagram of a control knob with a vertical bar and a double-headed arrow pointing up and down, indicating that the knob can be rotated to adjust values.</p>	<p>Configuration of the IF-Modules</p> <p>This setting is for configuring the IF Modules (e.g. baud rate, bit format)</p> <p>A, C, E and F are free parameters</p> <p>The layout of the menu and of individual parameters depends on the respective IF Module.</p> <p>See the installation and operating instructions for the IF Modules.</p> <hr/> <p> Turn the control button to adjust values.</p> <hr/> <p> The setting is applied</p> <hr/> <p>The display returns to the basic setting ②.</p>

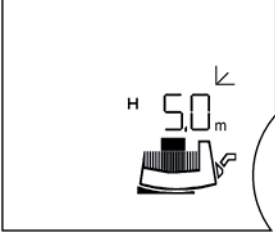
- **Options menu: setting of Heating (HV) / cooling air-conditioning (AC) operating mode and conversion from SI to US units.**

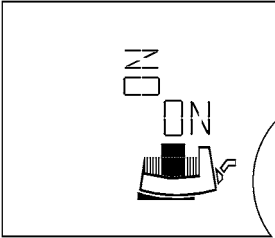
LC display	Setting
<p>②</p>  <p>The LC display shows 'H 50 m' at the top. Below it is a diagram of a control knob with a vertical bar and a double-headed arrow pointing up and down, indicating that the knob can be rotated to adjust values.</p>	<p>Setting of operating mode heating (HV) / cooling air-conditioning (AC)</p> <hr/> <p> In the basic setting (menu level 1), press the control button for > 6 s.</p>
<p>③</p>  <p>The LC display shows 'ON' at the top. Below it is a diagram of a control knob with a vertical bar and a double-headed arrow pointing up and down, indicating that the knob can be rotated to adjust values.</p>	<p>Within these 6 seconds, menu level 2 appears after approx. 1 s (menu item ③, display position setting).</p>

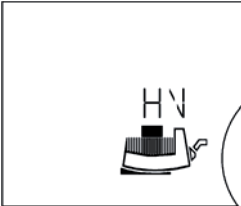
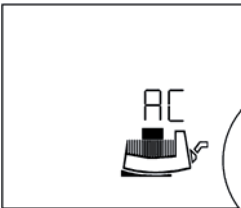
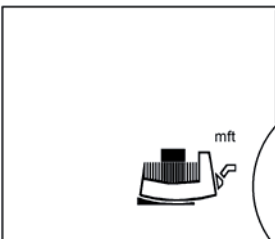
LC display	Setting
	<p>After another 5 seconds, the display switches to menu level 3. "HV" appears on the display (factory setting).</p>
	<p>Turning the control button switches the setting to cooling/air-conditioning (AC) operating mode. "AC" flashes.</p> <p>The setting is applied.</p> <p>The next menu is displayed.</p>
	<p>Switching from SI to US units</p> <p>"m ft" appears on the display and the currently set unit flashes (factory setting [m]).</p> <p>Turning the control button changes the setting to [ft]. The new setting starts to flash.</p> <p>The setting is applied.</p> <p>The display returns to the basic setting ②.</p>
<p>The basic setting is displayed again if no setting is made in the menu within 30 seconds ②.</p>	

• **Fault indication: single and double pump**

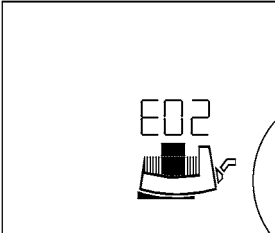
LC display	Setting
<p>⑩</p> 	<p>If a fault occurs, the current fault is indicated by E = error, the code no. and by the motor, control module or mains connection error source flashing.</p> <p>Refer to Chapter 10 for code numbers and their meaning.</p>

8.3 Selecting the control mode

System type	System conditions	Recommended control mode
Heating/ventilation/air-conditioning systems with resistance in the transfer section (room radiator + thermostatic valve) $\leq 25\%$ of the total resistance	<ol style="list-style-type: none"> Two-pipe system with thermostatic/zone valves and virtually no user authority <ul style="list-style-type: none"> $H_N > 4$ m Very long distribution lines Strongly throttled shut-off valves for pipe sections Sectional differential pressure control High pressure loss in system parts through which total volume flows (boiler/refrigerating machine, any heat exchanger, distribution line up to 1st branch) Primary circuits with high pressure loss Drinking water circulation systems with thermostatically controlled line shut-off valves 	$\Delta p-v$
Drinking water circulation systems with resistance in the generator circuit $\geq 50\%$ des Widerstandes im Steigestrang		
Heating/ventilation/air-conditioning systems with resistance in the generator/distribution circuit $\leq 25\%$ of the resistance in the transfer section (room radiator + thermostatic valve)	<ol style="list-style-type: none"> Two-pipe system with thermostatic/zone valves and high user authority <ul style="list-style-type: none"> $H_N \leq 2$ m Converted gravity heating systems Conversion to large temperature spread (e.g. district heating) Low pressure loss in system parts, through which total volume flows (boiler/cooling machine, any heat exchanger, distribution line up to 1st branch) Primary circuits with minor pressure loss Floor heating systems with thermostatic or zone valves One-pipe systems with thermostatic valves or shut-off valves for pipe sections 	$\Delta p-c$

System type	System conditions	Recommended control mode
Drinking water circulation systems with resistance in the generator circuit $\leq 50\%$ of the resistance in the ascending section	5. Drinking water circulation systems with thermostatically controlled line shut-off valves	$\Delta p-c$
Heating systems	<ol style="list-style-type: none"> 1. Two-pipe systems <ul style="list-style-type: none"> • Pump is installed in the feed pipe. • The feed temperature is controlled by atmospheric conditions. An increasing feed temperature increases the flow rate. 2. One-pipe systems <ul style="list-style-type: none"> • Pump is installed in the return pipe. • The feed temperature is constant. A falling feed temperature reduces the flow rate. 3. Primary circuits with condensing boiler <ul style="list-style-type: none"> • Pump is installed in the return pipe. A falling feed temperature reduces the flow rate. 	$\Delta p-T$
Drinking water circulation systems	4. Drinking water circulation systems with thermostatically controlled line shut-off valves or constant flow rate. If the temperature is increased in the circulation pipe, the flow rate is reduced.	
Heating-ventilation/air-conditioning systems Drinking water circulation systems	1. Constant flow rate	Manual control mode
Heating systems	<ol style="list-style-type: none"> 1. All systems <ul style="list-style-type: none"> • Pump is installed in the feed pipe. • The feed temperature falls during low load periods (e.g. at night). • The pump runs 24 hours without external control at the mains. 	Setback operation

8.4 Setting the pump performance

During planning, the unit is designed for a specific duty point (hydraulic full-load point for maximum heating power requirement calculated). During commissioning, the pump capacity (delivery head) must be set according to the duty point of the unit (see also 4.3). The factory setting does not comply with the pump capacity required for the system. It is determined with the help of the pump curve diagram for the selected pump type (from catalogue/data sheet). See also Fig. 8 to 10.

Δp -c, Δp -v and Δp -T control modes:

	Δp -c (Fig. 9)	Δp -v (Fig. 8)	Δp -T (Fig. 10)
Duty point on maximum curve	Draw from duty point towards the left. Read off setpoint H_S and set the pump to this value.		The settings are to be made by customer service taking the plant conditions into account, via the serial digital interface or using an IR operating and service unit (accessory).
Duty point within the control range	Draw from duty point towards the left. Read off setpoint H_S and set the pump to this value.	Go along the control curve up to the maximum curve, then move horizontally to the left. Read off the setpoint H_S and set the pump to this value.	
Adjustment range	H_{min} , H_{max} see 5.1 Type key		T_{min} : 20 ... 100 °C T_{max} : 30 ... 110 °C $\Delta T = T_{max} - T_{min} \geq 10$ °C Gradient: $\Delta H_s / \Delta T \leq 1$ m/10 °C H_{min} , H_{max} Adjustment in positive effective direction: $H_{max} > H_{min}$ Adjustment in negative effective direction: $H_{min} > H_{max}$

8.5 Operation

Faults of electronic devices due to electromagnetic fields

Electromagnetic fields are created during the operation of pumps with frequency converter. Interference of electronic devices may be the result. The result may be a device malfunction, which can result in damage to the health or even death, e.g. of persons carrying implanted active or passive medical devices. Therefore, during operation the presence of any persons e.g. with cardiac pacemakers in the vicinity of the unit/pump should be prohibited. With magnetic or electronic data media, the loss of data is possible.

8.6 Decommissioning

The pump must be decommissioned before conducting maintenance, repair or dismantling work.



DANGER! Risk of fatal injury!

An electric shock may occur when working on electrical equipment.

- **Have work on the electrical part of the pump carried out only by a qualified electrician as a basic principle.**
 - **Before starting any maintenance and repair work, disconnect the pump from the power supply, and make sure it cannot be switched back on by unauthorised persons.**
 - **Work on the module may only be started once 5 minutes have passed, due to the dangerous residual contact voltage (capacitors).**
 - **Check to ensure that all connections (including potential-free contacts) are voltage-free.**
 - **The pump may still be live even in voltage-free state. The drive rotor induces a dangerous contact voltage at the motor contacts.**
- Close the check valves in front of and behind the pump.**



WARNING! Risk of burns!

Touching the pump can cause burns! Depending on the operating status of the pump or unit (fluid temperature), the entire pump can become very hot. Allow the unit and pump to cool down to room temperature.

9 Maintenance

Before carrying out maintenance / cleaning and repair work, observe Chapters 8.5 "Operation" and 8.6 "Decommissioning".

The safety instructions in Chapter 2.6 and Chapter 7 must be complied with. After completing maintenance and repair work, install and connect the pump according to Chapter 7 "Installation and electrical connection". Switch on the pump according to Chapter 8 "Commissioning".

9.1 Dismantling / installation



WARNING! Risk of injury and damage to property!

Incorrect dismantling/installation can lead to injuries and damage to property.

- Touching the pump can cause burns! Depending on the operating status of the pump or unit (fluid temperature), the entire pump can become very hot.
- At high fluid temperatures and system pressures there is risk of scalding due to escaping hot fluid.

Before dismantling the motor, close the existing check valves on both sides of the pump, allow the pump to cool down to room temperature, and drain the isolated branch of the system. If no check valves are fitted, drain the entire system.

- Observe the manufacturer's information and safety data sheets on possible additives in the unit.
- Risk of injury due to the motor/pump falling when the fastening screws have been undone.

Comply with national regulations for accident prevention and also with the operator's internal works, company and safety regulations. If necessary, wear protective clothing and equipment!



WARNING! Danger due to strong magnetic field!

Inside the machine there is always a strong magnetic field that can cause injury and damage to property in the event of incorrect dismantling.

- It is only permitted to have the rotor removed from the motor housing by qualified personnel!
- There is a crushing hazard! When pulling the rotor out of the motor, it may be suddenly pulled back into its initial position by the strong magnetic field.
- If the unit consisting of impeller, bearing shield and rotor is pulled out of the motor, persons with medical aids, such as cardiac pacemakers, insulin pumps, hearing aids, implants or similar are at risk. Death, severe injury and damage to property may be the result. For such persons, a professional medical assessment is always necessary.
- Electronic devices may be impaired functionally or damaged by the strong magnetic field of the rotor.
- If the rotor is outside the motor, magnetic objects may be attracted very suddenly. That can result in injury and damage to property.

In assembled condition, the rotor's magnetic field is guided in the motor's iron core. There is therefore no harmful magnetic field outside the machine.



DANGER! Risk of fatal electrical shock!

Even without the module (without electrical connection), there may be dangerous contact voltage at the motor contacts.

Observe the warning on the front side of the motor: "Attention – Generator voltage".

The motor does not have to be completely removed from the pump housing if only the control module is to be repositioned. The motor can be turned to the desired position whilst still attached to the pump housing (see permissible installation positions as per Fig. 2a and Fig. 2b).



CAUTION! Risk of damage to property!

If for maintenance or repair work the motor head is detached from the pump housing, the O ring located between the motor head and pump housing must be replaced with a new one. When installing the motor head, check that the O ring is correctly seated.

- To release the motor, undo four socket-head screws. Tools that may be required:
 - Angled hexagonal socket screwdriver
 - Ball-head hexagonal socket screwdriver
 - ¼-inch ratchet wrench with appropriate bit



CAUTION! Risk of damage to property!

Do not damage the O ring located between the motor head and the pump housing. The O ring must lie in the angled end shield that faces the impeller, and must not be twisted.

- After the installation tighten the 4 socket-head screws again crosswise.
- The control module can be disconnected from the motor by undoing two screws if the screws on the motor flange cannot be accessed, see Chapter 9.2.
- For the commissioning of the pump, see Chapter 8.

9.2 Dismantling / installation of the control module



WARNING! Risk of injury and damage to property!

Incorrect dismantling/installation can lead to injuries and damage to property. Observe the hazard information in Chapter 9.1.



DANGER! Risk of fatal electrical shock!

Even without the module (without electrical connection), there may be dangerous contact voltage at the motor contacts (cause: generator operation when fluid flows through the pump). Do not stick any objects (e.g. nail, screwdriver, wire) into the motor's contacts.

The control module is disconnected from the motor by undoing two screws (Fig. 4):

- Undo the screws of the terminal box cover (item 1)
- Remove the terminal box cover (item 2).
- Undo the M5 internal hexagon screws (SW4) in the control module (item 3)
- Pull the control module off the motor (item 4).
- Install the module in the reverse order. Do not forget to install the flat gasket (item 5) between the motor housing and control module.

10 Faults, causes and remedies

Refer to the "Fault signal / warning signal" flow diagram and **Tables 10, 10.1, 10.2** for troubleshooting.

Faults	Causes	Remedy
Pump is not running although the power supply is switched on.	Electrical fuse defective.	Check fuses.
	Pump has no voltage.	Reconnect the voltage.
Pump is making noises.	Cavitation due to insufficient suction pressure.	Increase the system suction pressure within the permissible range.
		Check the delivery head and set it to a lower height if necessary.

Table 10: Faults with external interference sources

10.1 Fault signals – Heating/ventilation HV operating mode

- A fault occurs.
- The pump goes off, the fault signal LED (continuous red light) is activated.
Double pump: The standby pump is switched on.
- The pump automatically goes on again after a delay of five minutes.
- The transmission of the fault via the serial digital interface depends on the type of IF Module.
For details, see the documentation (Installation and operating instructions of the IF Module).
- Only if the fault occurs for the 6th time within 24 hours does the pump go off permanently, SSM opens.
Then, the fault needs to be reset by hand.



EXCEPTION: The pump goes off immediately whenever a fault occurs for the first time with the code number "E10" and "E25".

10.2 Fault signals – Air-conditioning AC operating mode

- A fault occurs.
- The pump goes off, the fault signal LED (continuous red light) is activated. The error message appears on the display, SSM opens. Then, the fault needs to be reset by hand.
Double pump: The standby pump is switched on.
- The transmission of the fault via the serial digital interface depends on the type of IF Module.
For details, see the documentation (Installation and operating instructions of the IF Module).



NOTE: Code nos. "E04" (mains undervoltage) and "E05" (mains overvoltage) are treated as faults only during AC operation and lead to immediate deactivation.

Code no.	Symbol flashing	Fault	Cause	Remedy
E04	Line terminal	Mains undervoltage	Mains overloaded	Check electrical installation
E05	Line terminal	Mains overvoltage	Faulty supply by the electricity supply company	Check electrical installation
E10	Motor	Pump blockage	e.g. due to deposits	Unblocking routine starts automatically. If the blockage is not removed after a maximum of 40 seconds, the pump goes off. Request customer service
E20	Motor	Excess winding temperature	Motor overloaded	Allow motor to cool down, check setting
			Water temperature too high	Reduce water temperature
E21	Motor	Motor overload	Deposits in the pump	Request customer service
E23	Motor	Short circuit/earth leakage	Motor/module defective	Request customer service
E25	Motor	Faulty contact	Module not connected properly	Re-connect module
E30	Module	Excess module temperature	Limited air supply to module heat sink	Provide unobstructed air access
E31	Module	Excess power section temperature	Ambient temperature too high	Improve room ventilation
E36	Module	Module defective	Electronic components defective	Request customer service/replace module

Table 10.1: Fault signals

10.3 Warning signals

- The fault (warning only) is indicated.
- The fault signal LED and the SSM relay do not respond.
- The pump continues to run. The fault may occur any number of times.
- The indicated faulty operating status must not occur for a prolonged period. The cause must be eliminated.



EXCEPTION: If the "E04" and "E05" warnings apply in HV operating mode for longer than 5 minutes, they are transmitted as fault signals (see Chapter 10.1).

- The transmission of the fault via the serial digital interface depends on the type of IF Module.

For details, see the documentation (Installation and operating instructions of the IF Module).

Code no.	Symbol flashing	Fault	Cause	Remedy
E03		Water temperature >110 °C	Heating control set incorrectly	Set to lower temperature
E04		Mains undervoltage	Mains overloaded	Check electrical installation
E05		Mains overvoltage	Faulty supply by the electricity supply company	Check electrical installation
E07		1. Generator operation	Driven by the admission pressure pump (the pump is flowed through from the suction to the pressure side)	Synchronise power control of pumps
		2. Turbine operation	The pump is driven backwards (the pump is flowed through from the pressure to the suction side)	Check flow, install non-return valves if necessary
E09*)		Turbine operation	The pump is driven backwards (the pump is flowed through from the pressure to the suction side)	Check flow, install non-return valves if necessary
E11		Pump idling	Air in the pump	Vent the pump and unit
E38	Motor	Fluid temperature sensor defective	Motor defective	Request customer service

Code no.	Symbol flashing	Fault	Cause	Remedy
E50		Bus communication fault	Interface, core defective, IF Modules not connected properly, cable defective	The control system is switched to local control mode via the interface after 5 minutes
E51		Invalid master/slave combination	Different pumps	Single pumps: Use the same pump types. Double pump: Request customer service or read the pump type at MA and SL using an IR device. If the module types deviate, request the corresponding replacement module
E52		Master/slave communication error	IF Modules not correctly plugged in, cable defective	The modules switch over to single pump operation after 5 s. Plug modules back in, check cables
E53		Invalid bus address	Same bus address assigned twice	Carry out addressing on the module once again
E54		I/O module connection	I/O module connection interrupted	Check connection
MA		Master/slave not set		Define the master and slave

*) Only for pumps with $P1 \geq 800W$

Table 10.2: Warning signals

If the operating fault cannot be remedied, please consult skilled craft firms or the nearest Wilo customer service point or representative.

Flow diagram – Fault/warning signal during HV operation

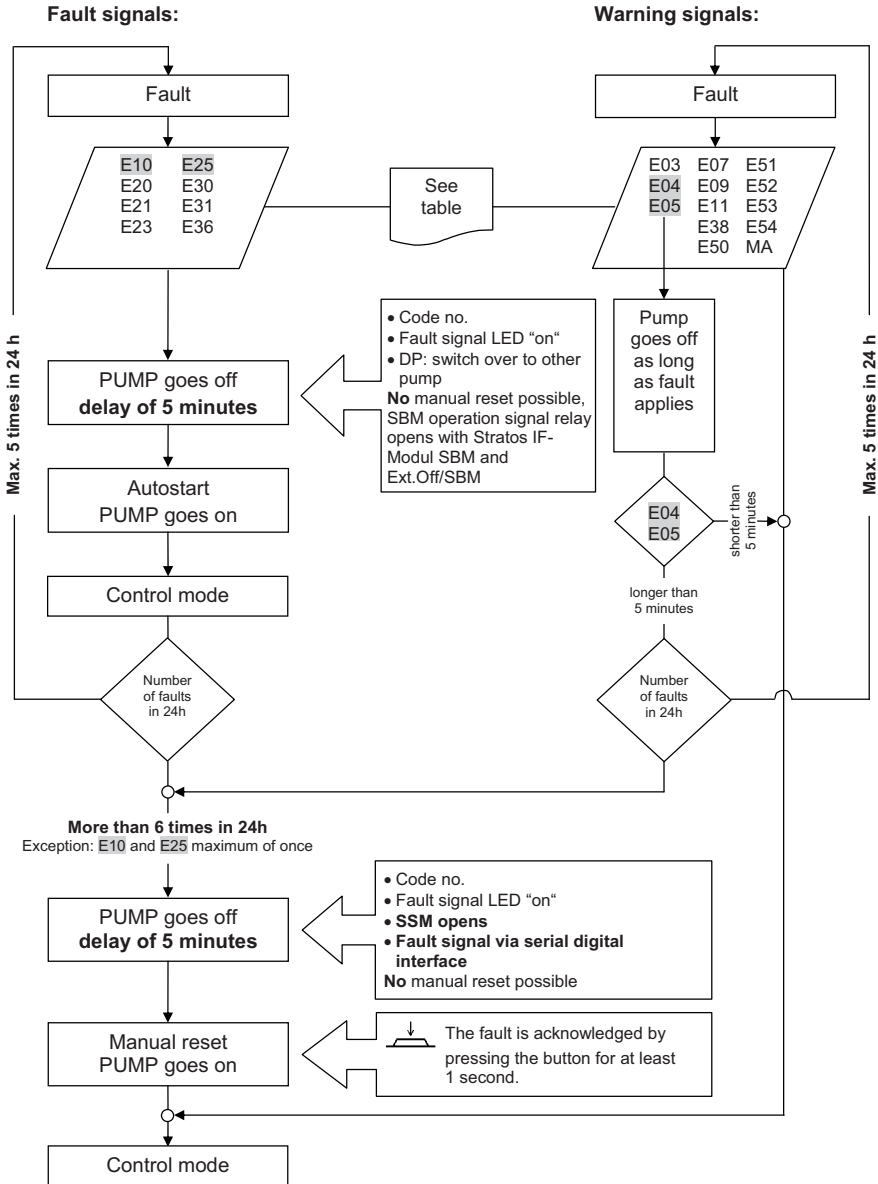

Flow diagram – Fault/warning signal during AC operation

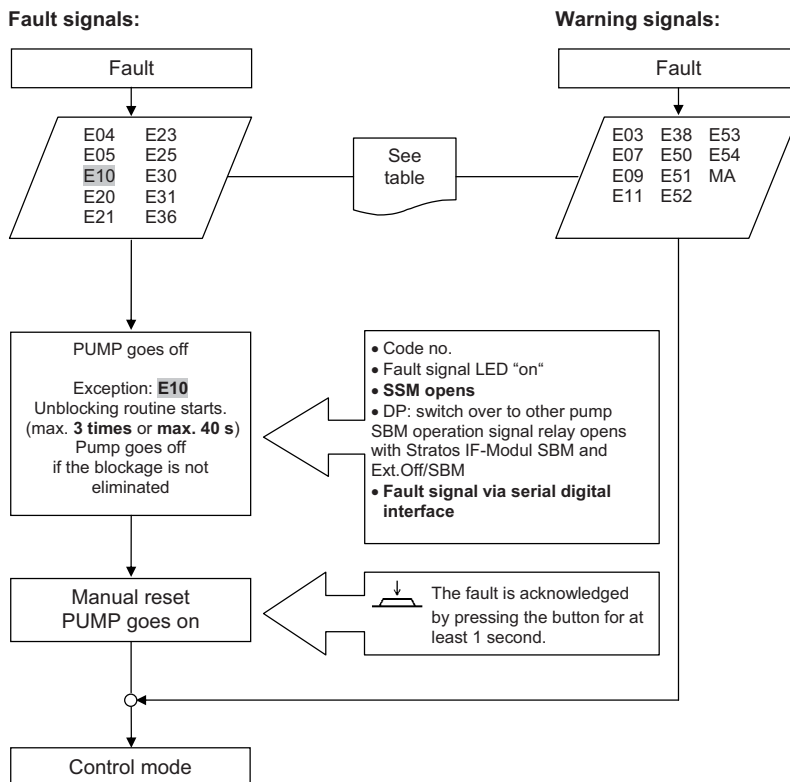

11 Spare parts

Spare parts can be ordered from your local specialist and/or via Wilo customer service.

In order to avoid queries and incorrect orders, the entire data on the name plate should be submitted for each order.

12 Disposal

Proper disposal and recycling of this product prevents damage to the environment and risks to personal health.

For dismantling and disposal of the motor, do not fail to observe the warnings in Chapter 9.1!

1. Use public or private disposal organisations when disposing of the entire product or part of the product
2. For more information on proper disposal, please contact your local council or waste disposal office or the supplier from whom you obtained the product.



NOTE:

The pump must not be disposed of along with household waste!

Technical information subject to change without prior notice!

D EG – Konformitätserklärung
GB EC – Declaration of conformity
F Déclaration de conformité CE

(gemäß 2006/42/EG Anhang II,1A und 2004/108/EG Anhang IV,2,
according 2006/42/EC annex II,1A and 2004/108/EC annex IV,2,
conforme 2006/42/CE appendice II,1A et 2004/108/CE appendice IV,2)

Hiermit erklären wir, dass die Bauart der Baureihe :
Herewith, we declare that the product type of the series:
Par le présent, nous déclarons que l'agrégat de la série :

Stratos
Stratos-D
Stratos-Z

(Die Seriennummer ist auf dem Typenschild des Produktes angegeben. /
The serial number is marked on the product site plate. /
Le numéro de série est inscrit sur la plaque signalétique du produit.)

in der gelieferten Ausführung folgenden einschlägigen Bestimmungen entspricht:
in its delivered state complies with the following relevant provisions:
est conforme aux dispositions suivantes dont il relève:

EG-Maschinenrichtlinie
EC-Machinery directive

2006/42/EG

Directives CE relatives aux machines

Die Schutzziele der Niederspannungsrichtlinie 2006/95/EG werden gemäß Anhang I, Nr. 1.5.1 der Maschinenrichtlinie 2006/42/EG eingehalten.

The protection objectives of the low-voltage directive 2006/95/EC are realized according annex I, No. 1.5.1 of the EC-Machinery directive 2006/42/EC.

Les objectifs protection de la directive basse-tension 2006/95/CE sont respectées conformément à appendice I, n° 1.5.1 de la directive CE relatives aux machines 2006/42/CE.

Elektromagnetische Verträglichkeit – Richtlinie
Electromagnetic compatibility – directive
Compatibilité électromagnétique – directive

2004/108/EG

Angewendete harmonisierte Normen, insbesondere:
Applied harmonized standards, in particular:
Normes harmonisées, notamment:

EN 809
EN ISO 12100-1
EN ISO 12100-2
EN ISO 14121-1
EN 60335-1
EN 60335-2-51
EN 61800-3
EN 61800-5-1

Bei einer mit uns nicht abgestimmten technischen Änderung der oben genannten Bauarten, verliert diese Erklärung ihre Gültigkeit.
If the above mentioned series are technically modified without our approval, this declaration shall no longer be applicable.
Si les gammes mentionnées ci-dessus sont modifiées sans notre approbation, cette déclaration perd sa validité.

Bevollmächtigter für die Zusammenstellung der technischen Unterlagen ist:
Authorized representative for the completion of the technical documentation is:
Mandataire pour le complément de la documentation technique est :

WILO SE
Division Circulators – PBU Big Circulators
Engineering
Nortkirchenstraße 100
44263 Dortmund
Germany

Dortmund, 21.02.2011

i. V. Erwin Prieß
Quality Manager



WILO SE
Nortkirchenstraße 100
44263 Dortmund
Germany



WILO SE
Nortkirchenstraße 100
44263 Dortmund
Germany
T 0231 4102-0
F 0231 4102-7363
wilo@wilo.com
www.wilo.de

Wilo-Vertriebsbüros in Deutschland

Nord

WILO SE

Vertriebsbüro Hamburg
Beim Strohhause 27
20097 Hamburg
T 040 5559490
F 040 5559494
hamburg.anfragen@wilo.com

Ost

WILO SE

Vertriebsbüro Dresden
Frankenring 8
01723 Kesselsdorf
T 035204 7050
F 035204 70570
dresden.anfragen@wilo.com

Süd-West

WILO SE

Vertriebsbüro Stuttgart
Hertichstraße 10
71229 Leonberg
T 07152 94710
F 07152 947141
stuttgart.anfragen@wilo.com

West

WILO SE

Vertriebsbüro Düsseldorf
Westring 19
40721 Hilden
T 02103 90920
F 02103 909215
duesseldorf.anfragen@wilo.com

Nord-Ost

WILO SE

Vertriebsbüro Berlin
Juliusstraße 52-53
12051 Berlin-Neukölln
T 030 6289370
F 030 62893770
berlin.anfragen@wilo.com

Süd-Ost

WILO SE

Vertriebsbüro München
Adams-Lehmann-Straße 44
80797 München
T 089 4200090
F 089 42000944
muenchen.anfragen@wilo.com

Mitte

WILO SE

Vertriebsbüro Frankfurt
An den drei Hasen 31
61440 Oberursel/Ts.
T 06171 70460
F 06171 704665
frankfurt.anfragen@wilo.com

Kompetenz-Team Gebäudetechnik

WILO SE

Nortkirchenstraße 100
44263 Dortmund
T 0231 4102-7516
T 01805 R-U-F-W-L-O*
7-8-3-9-4-5-6
F 0231 4102-7666

Erreichbar Mo-Do 7-18 Uhr, Fr 7-17 Uhr.

- Antworten auf
 - Produkt- und Anwendungsfragen
 - Liefertermine und Lieferzeiten
- Informationen über Ansprechpartner vor Ort
- Versand von Informationsunterlagen

Standorte weiterer Tochtergesellschaften

Die Kontaktdaten finden
Sie unter www.wilo.com.

Kompetenz-Team Kommune Bau + Bergbau

WILO SE, Werk Hof

Heimgartenstraße 1-3
95030 Hof
T 09281 974-550
F 09281 974-551

Werkskundendienst Gebäudetechnik Kommune Bau + Bergbau Industrie

WILO SE

Nortkirchenstraße 100
44263 Dortmund
T 0231 4102-7900
T 01805 W-L-O-K-D*
9-4-5-6-5-3
F 0231 4102-7126
kundendienst@wilo.com

Täglich 7-18 Uhr erreichbar
24 Stunden Technische
Notfallunterstützung

- Kundendienst-
Anforderung
- Werksreparaturen
- Ersatzteilfragen
- Inbetriebnahme
- Inspektion
- Technische
Service-Beratung
- Qualitätsanalyse

Wilo-International

Österreich

Zentrale Wiener
Neudorf:
WILO Pumpen Österreich
GmbH
Wilo Straße 1
A-2351 Wiener
Neudorf
T +43 507 507-0
F +43 507 507-15
office@wilo.at
www.wilo.at

Vertriebsbüro Salzburg:
Gnigler Straße 56
A-5020 Salzburg
T +43 507 507-13
F +43 662 878470
office.salzburg@wilo.at
www.wilo.at

Vertriebsbüro
Oberösterreich:
Trattnachalstraße 7
A-4710 Grieskirchen
T +43 507 507-26
F +43 7248 65054
office.oberoester-
reich@wilo.at
www.wilo.at

Schweiz

EMB Pumpen AG
Gerstenweg 7
CH-4310 Rheinfelden
T +41 61 83680-20
F +41 61 83680-21
info@emb-pumpen.ch
www.emb-pumpen.ch

* 0,14 €/Min. aus dem Festnetz,
Mobilfunk max. 0,42 €/Min.