



atac

ATAC Solutions Ltd is a leading environmental engineering company based in Maidstone, United Kingdom.

ATAC Solutions is known for its state-of-the-art liquid collection fleet and its expertise in providing bespoke turnkey wastewater process solutions.

With a focus on sustainability and accreditation in ISO 9001 & ISO 14001, the company serves domestic and industrial clients across the South-East and London.

ATAC Solutions Ltd,
Unit A9, Loc 8 Business Park, Ashford Road,
Hollingbourne, Maidstone, England, ME17 1WR

 [atacsolutions.com](https://www.atacsolutions.com)
 01622 882400

Axiom Water companies

Phone
Fax

XS-F
System : Lifting plant



Customer
Customer no.
Contact
Care of

Project
Project no.
Position no.
Location
Date

2012-07-16

Page 1 / 1

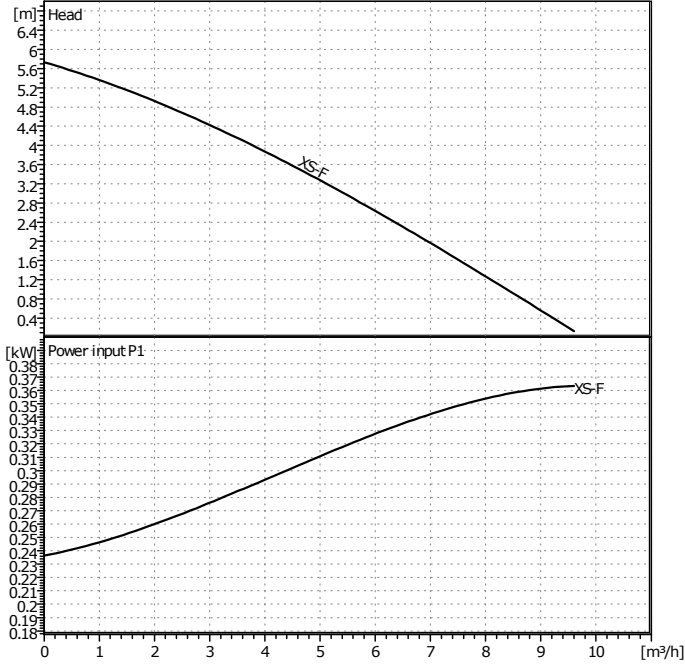

Requested data

Flow	0	m ³ /h
Head	0	m
Fluid	Water, pure	
Fluid temperature	20	°C
Density	0.9983	kg/dm ³
Kinematic viscosity	1.005	mm ² /s
Vapor pressure	0.02337	bar

Pump data

Make	WILO	
Type	XS-F	
Pumpe type	Single head pump	
Pressure rating	PN 6	
Min. fluid temperature	0	°C
Max. fluid temperature	35	°C

Hydraulic data (duty point)

Flow		m ³ /h
Head		m
Speed	2900	1/min
Impeller size	0	mm

Materials / Shaft seal

Motor housing	1.4301
Housing	Polyurethan
Reservoir	ABS

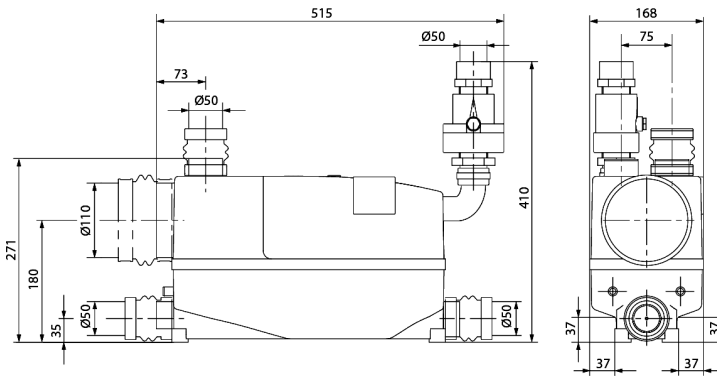

Dimensions per pump

		mm					

Suction side	-	/ PN 0
Discharge side	DN 32	/ PN 0
Weight	6.5	kg
Free passage	25	mm

Motordata per Motor/Pump/

Rated power P2	0.18	kW
Nominal speed	2900	1/min
Rated voltage	1~230 V, 50 Hz	
Max. current	1.8	A
Degree of protection	IP 44	
Permitted voltage tolerance	+/- 10%	

Item no. of standard version 2526945