



# atac

ATAC Solutions Ltd is a leading environmental engineering company based in Maidstone, United Kingdom.

ATAC Solutions is known for its state-of-the-art liquid collection fleet and its expertise in providing bespoke turnkey wastewater process solutions.

With a focus on sustainability and accreditation in ISO 9001 & ISO 14001, the company serves domestic and industrial clients across the South-East and London.

ATAC Solutions Ltd,  
Unit A9, Loc 8 Business Park, Ashford Road,  
Hollingbourne, Maidstone, England, ME17 1WR

 [atacsolutions.com](https://www.atacsolutions.com)  
 01622 882400

     

Axiom Water companies



# TP, TPD, TPE, TPED

In-line circulator pumps  
50 Hz

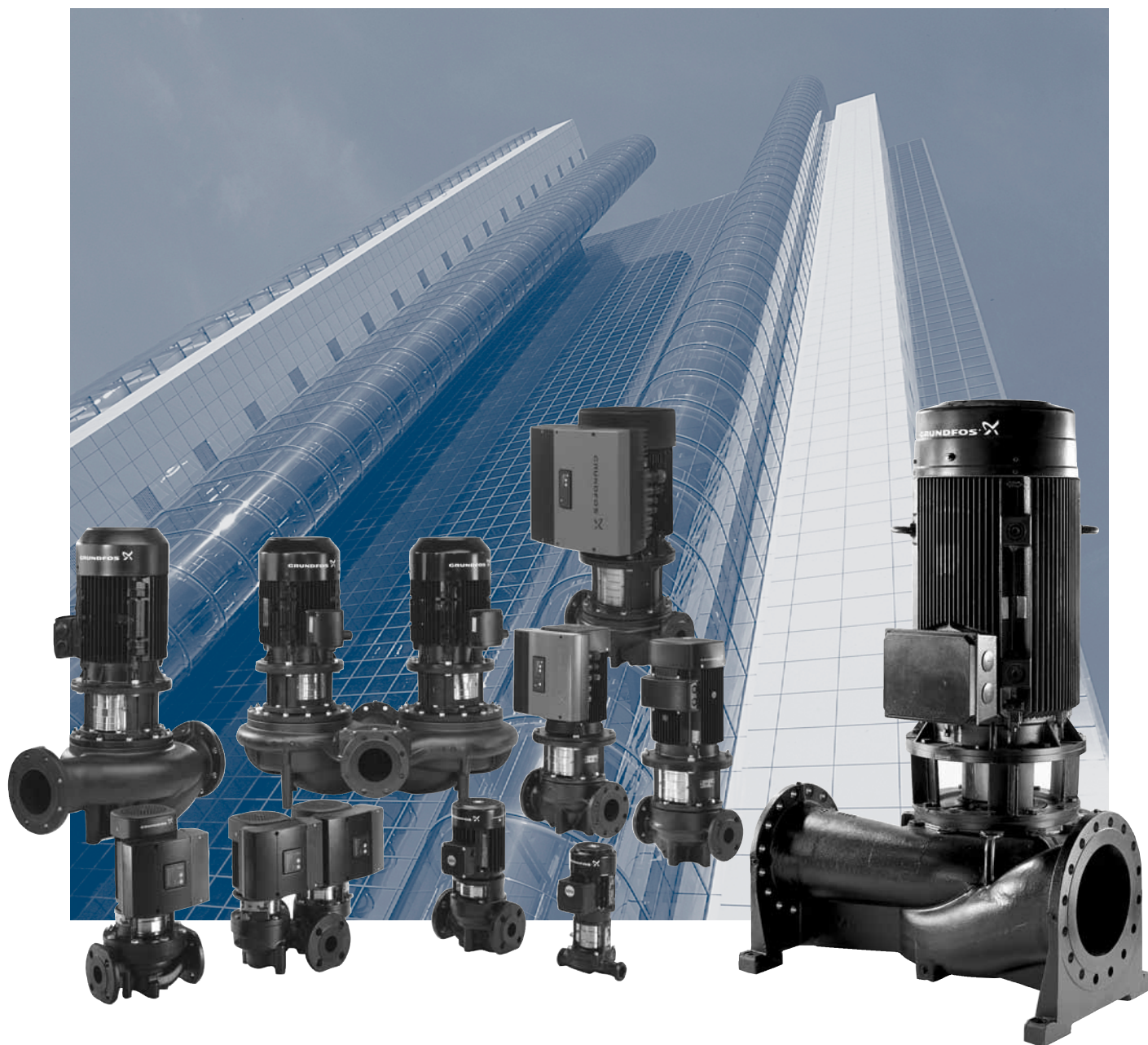

# Contents

## Pump data

Introduction	4
TP, mains-operated pumps	4
TPE, speed-controlled pumps	4
Type key	5
Codes for shaft seal	5

## Performance range

Performance range, 2-pole, PN 6, 10, 16	6
Performance range, 4-pole, PN 6, 10, 16	7
Performance range, 6-pole, PN 16	8
Performance range, 2-pole, PN 25	9
Performance range, 4-pole, PN 25	10

## Product range

Product range, 2-pole, 6, 10, 16	11
Product range, 4-pole, PN 6, 10, 16	13
Product range, 6-pole, PN 16	15
Product range, 2-pole, PN 25	15
Product range, 4-pole, PN 25	16

## Operating conditions

System and test pressures	17
Sound pressure level	17
Ambient temperature	17

## Pumped liquids

Pumped liquids	18
Liquid temperature	18
List of pumped liquids	19

## TP Series 100 and 200 pumps

Technical data	21
Construction	21
Materials	21
Mechanical shaft seal	22
Connections	22
Features and benefits	22

## TP Series 300 pumps

Technical data	23
Construction	23
Materials	23
Mechanical shaft seal	23
Connections	24
Features and benefits	24

## TP Series 400 pumps

Technical data	25
Construction	25
Materials	25
Mechanical shaft seal	26
Connections	26
Features and benefits	26

## TPE Series 1000 pumps

Technical data	27
Construction	27
Applications	27
Operating modes of twin-head pumps	28
Control options	28

## TPE Series 2000 pumps

Technical data	29
Construction	29
Applications	29
Operating modes of twin-head pumps	30
Control options	30

## Communication

Communication with TPE, TPED pumps	31
------------------------------------	----

## Speed regulation of TPE pumps

Affinity equations	32
--------------------	----

## TP, TPE pumps in parallel

Control of TP, TPE pumps connected in parallel	33
Alternation / standby function for TPED pumps	33
TP, TPE pumps connected to Control MPC	33
TPE Series 2000 pumps connected to Control MPC Series 2000	34

## Grundfos CUE

TP pumps connected to Grundfos CUE, external frequency converters	35
Functions	35

## Motor data

Motors	36
Motor protection	37
Electrical data, mains-operated motors	38
Electrical data, speed-controlled motors	39

## Installation

Mechanical installation	40
Electrical installation	45

# Contents

---

## Flanges for TP pumps

Flange dimensions	47
-------------------	----

## Curve charts

How to read the curve charts	48
Curve conditions	49

## Technical data/performance curves

TP, TPD, TPE, TPED, 2-pole, PN 6, 10, 16	50
TP, TPD, TPE, TPED, 4-pole, PN 6, 10, 16	72
TP, TPD, TPE, TPED, 6-pole, PN 16	98
TP, 2-pole, PN 25	102
TP, 4-pole, PN 25	104

## Weights and shipping volume

TP, TPD, TPE, TPED, 2-pole, PN 6, 10, 16	118
TP, TPD, TPE, TPED, 4-pole, PN 6, 10, 16	119
TP, TPD, 6-pole, PN 6, 10, 16	121
TP, 2-pole, PN 25	121
TP, 4-pole, PN 25	121

## Accessories

Unions and valves	123
Counter flanges	124
Base plates	127
Blanking flanges	129
Insulating kits	133
Sensors	134
Potentiometer	135
R100	135
CIU communication interface units	135
CIM communication interface modules	136
EMC filter	136

## Minimum inlet pressure - NPSH

TP, TPD 2-pole, PN 6, 10, 16	138
TP, TPD 4-pole, PN 6, 10, 16	139
TP, TPD 6-pole, PN 16	139
TP Series 400, 2-pole, PN 25	139
TP Series 400, 4-pole, PN 25	140

## Further product documentation

WebCAPS	141
WinCAPS	142

## Introduction

TP pumps are designed for applications such as

- district heating systems
- heating systems
- air-conditioning systems
- district cooling systems
- water supply
- industrial processes
- industrial cooling.

The pumps are available with either mains-operated motors (TP and TPD) or electronically speed-controlled motors (TPE and TPED).

The pumps are all single-stage, in-line centrifugal pumps with mechanical shaft seal. The pumps are of the close-coupled type, i.e. pump and motor are separate units. Consequently, the pumps are less sensitive to impurities in the pumped liquid than similar pumps of the canned rotor type.

### TP, mains-operated pumps

The TP range is divided into the following four groups based on their construction: TP Series 100, 200, 300 and 400.

#### TP Series 100 with union or flange connection

Rp 1 (DN 25) to Rp 1¼ (DN 32) and motor sizes from 0.12 to 0.25 kW.

For further information, see page 21.

#### TP Series 200 with flange connection

DN 32 to DN 100 and motor sizes from 0.12 to 2.2 kW.

For further information, see page 21.

#### TP Series 300 with flange connection

DN 32 to DN 200 and motor sizes from 0.25 to 132 kW.

For further information, see page 23.

#### TP Series 400 with flange connection

Grundfos offers two TP Series 400 versions:

- 10 bar version with DN 250 flange and motor sizes from 45 to 75 kW.
- 25 bar version with DN 100 to DN 400 and motor sizes from 5.5 to 630 kW.

For further information, see page 25.

### TPE, speed-controlled pumps

Based on the construction and choice of material of TP pumps, Grundfos offers the following two series of speed-controlled TPE pumps:

- TPE Series 1000 pumps (without factory-fitted differential-pressure sensor)
- TPE Series 2000 pumps (with factory-fitted differential-pressure sensor)

### TPE Series 1000 pumps

The difference between the TP and the TPE Series 1000 pump range is the motor. The motors of TPE Series 1000 pumps have built-in frequency converter.

Via an external signal (from a sensor or a controller), TPE Series 1000 pumps allow for any configuration and control method required: Constant pressure, temperature or flow.

For further information, see page 27.

### TPE Series 2000 pumps

The main differences between the TP and the TPE Series 2000 pumps are the motor and the factory-fitted differential-pressure sensor.

TPE Series 2000 pumps are factory-set to proportional-pressure control.

The motors of TPE Series 2000 pumps have built-in frequency converter for continuous adjustment of the pressure to the flow rate.

The TPE Series 2000 range is recognized as a preset solution for quick and safe installation.

For further information, see page 29.

### Why select a TPE pump?

A TPE pump with electronic speed control offers these obvious benefits:

- energy savings
- increased comfort
- control and monitoring of pump performance
- communication with the pump.

### ATEX-approved TP pumps

On request, Grundfos offers TP and TPD pumps with ATEX-approval.

All ATEX-approved TP pumps are in accordance with Council directive 94/9/EC (Group II, category 3).

If an ATEX-approved dry-running protection is installed, the pump can be upgraded to category 2G.

### High-efficiency motors

TP pumps are fitted with high-efficiency motors.

2- and 4-pole TP pumps with motor sizes from 1.1 to 90 kW are fitted with high-efficiency motors (EFF1). EFF1 is the highest efficiency class defined by CEMEP.



## Type key

Example	TP	E	D	65	-120	/2	-S	-A	-F	-A	-AUUE
Pump range											
Electronically speed-controlled pump (Series 1000, 2000)											
Twin-head pump											
Nominal diameter of suction and discharge ports (DN)											
Maximum head [dm]											
Pole number											
S = TPE Series 2000 (with factory-fitted differential pressure sensor)											
Code for pump version: A = Basic version I = PN 6 flange X = Special version											
Code for pipework connection: F = DIN flange O = Union											
Code for materials: A = Basic version Z = Bronze pump housing and pump head B = Bronze impeller											
Code for shaft seal (incl. other plastic and rubber pump parts, except the neck ring)											

## Codes for shaft seal

Example	B	B	U	E
<b>Grundfos type designation</b> A = O-ring seal with fixed seal driver B = Rubber bellows seal D = O-ring seal, balanced G = Bellows seal with reduced seal faces R = O-ring seal with reduced seal faces				
<b>Material of rotating face</b> A = Carbon, antimony-impregnated B = Carbon, resin-impregnated Q = Silicon carbide U = Tungsten carbide				
<b>Material of stationary seat</b> B = Carbon, resin-impregnated Q = Silicon carbide U = Tungsten carbide				
<b>Material of secondary seal</b> E = EPDM P = NBR rubber V = FKM				



# Performance range

TP, TPD, TPE, TPED  
4-pole, PN 6, 10, 16

## Performance range, 4-pole, PN 6, 10, 16

(See page 72 for performance curves)

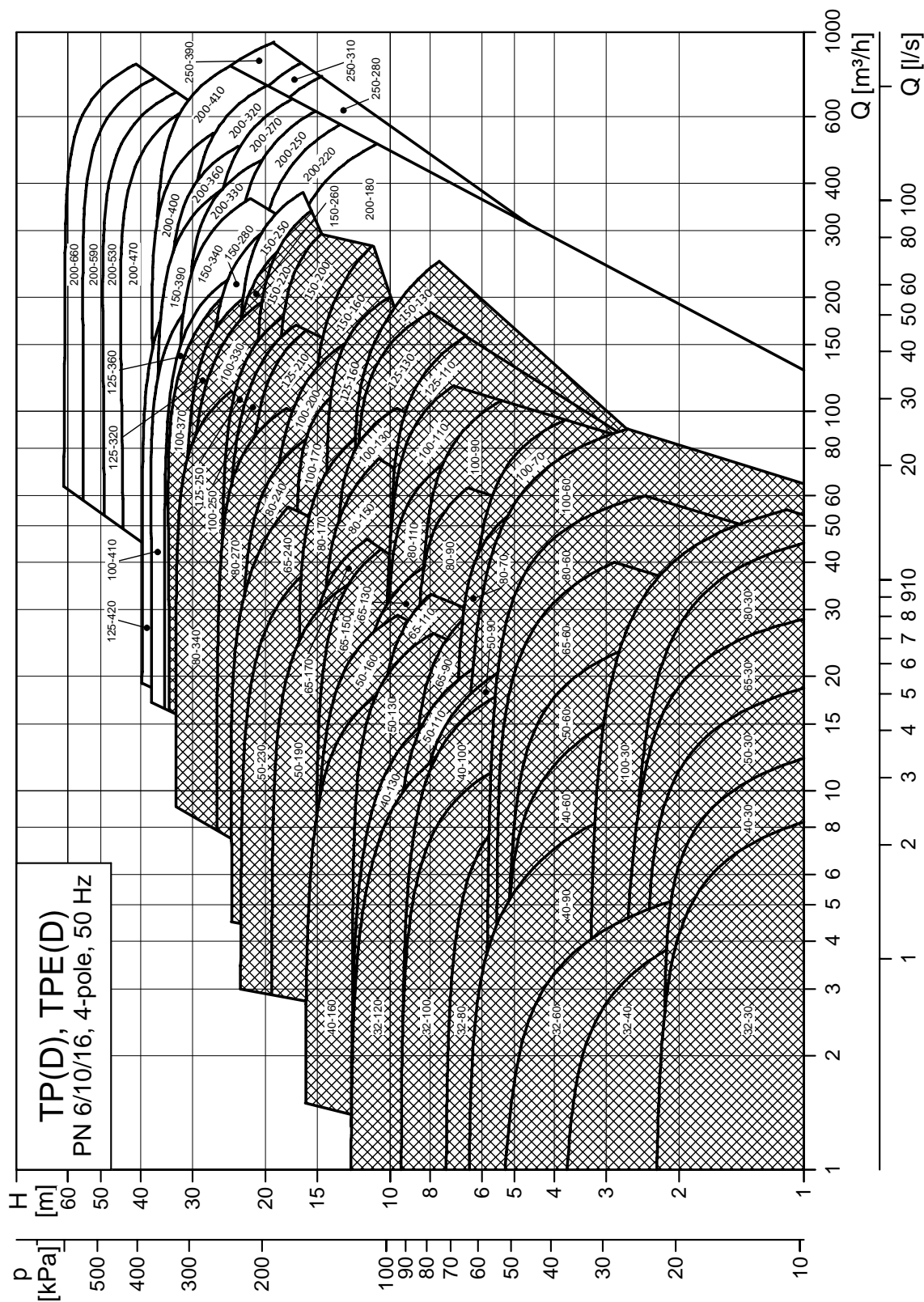

**Note:** All QH curves apply to single-head pumps. For further information about curve conditions, see page 49. The hatched area shows the performance range of TPE pumps.

TM02 7551 4008

## Performance range, 6-pole, PN 16

(See page 98 for performance curves)

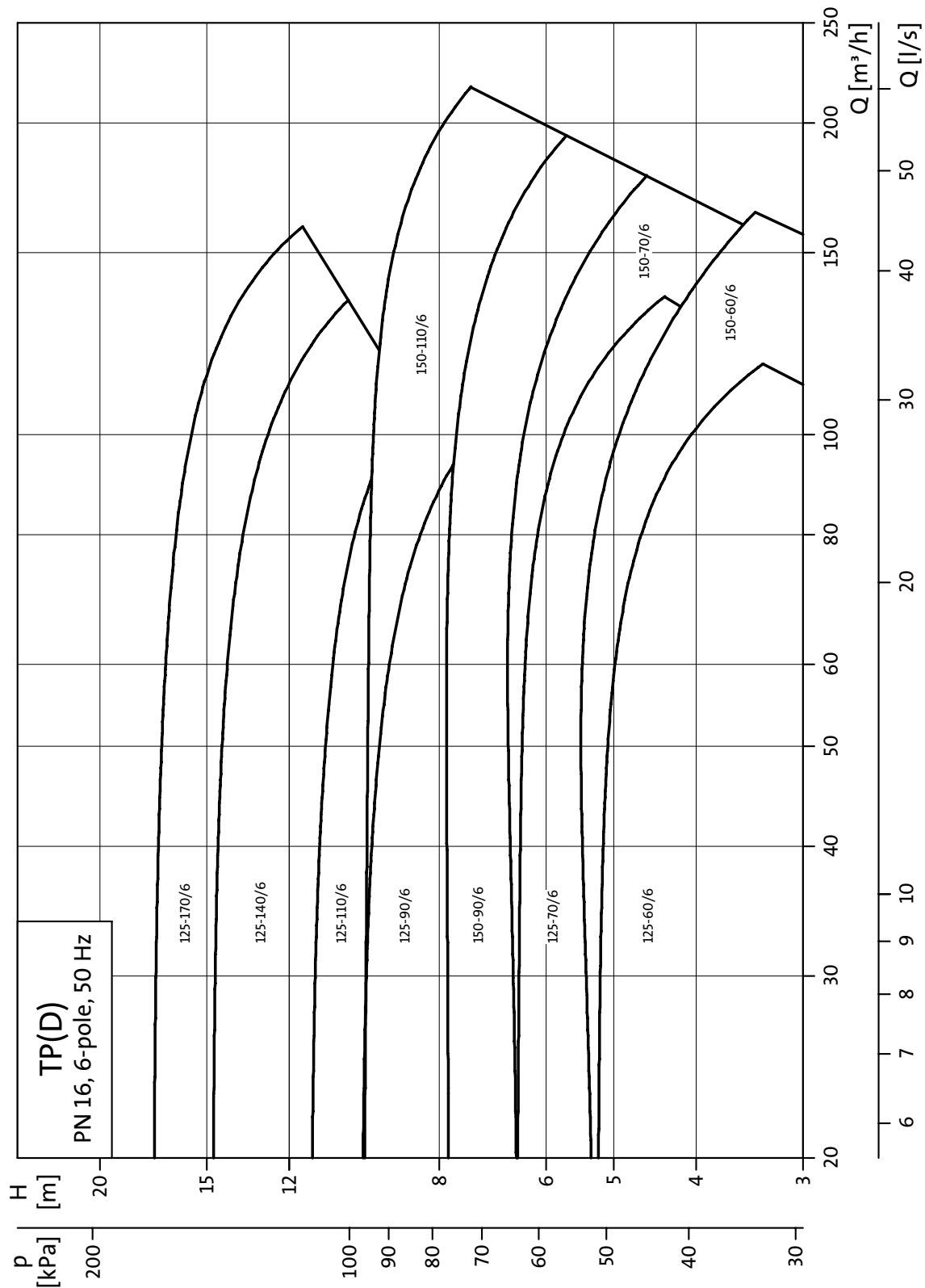

TM02 8768 0904

**Note:** All QH curves apply to single-head pumps. For further information about curve conditions, see page 49.

# Performance range

TP  
2-pole, PN 25

## Performance range, 2-pole, PN 25

(See page 102 for performance curves)

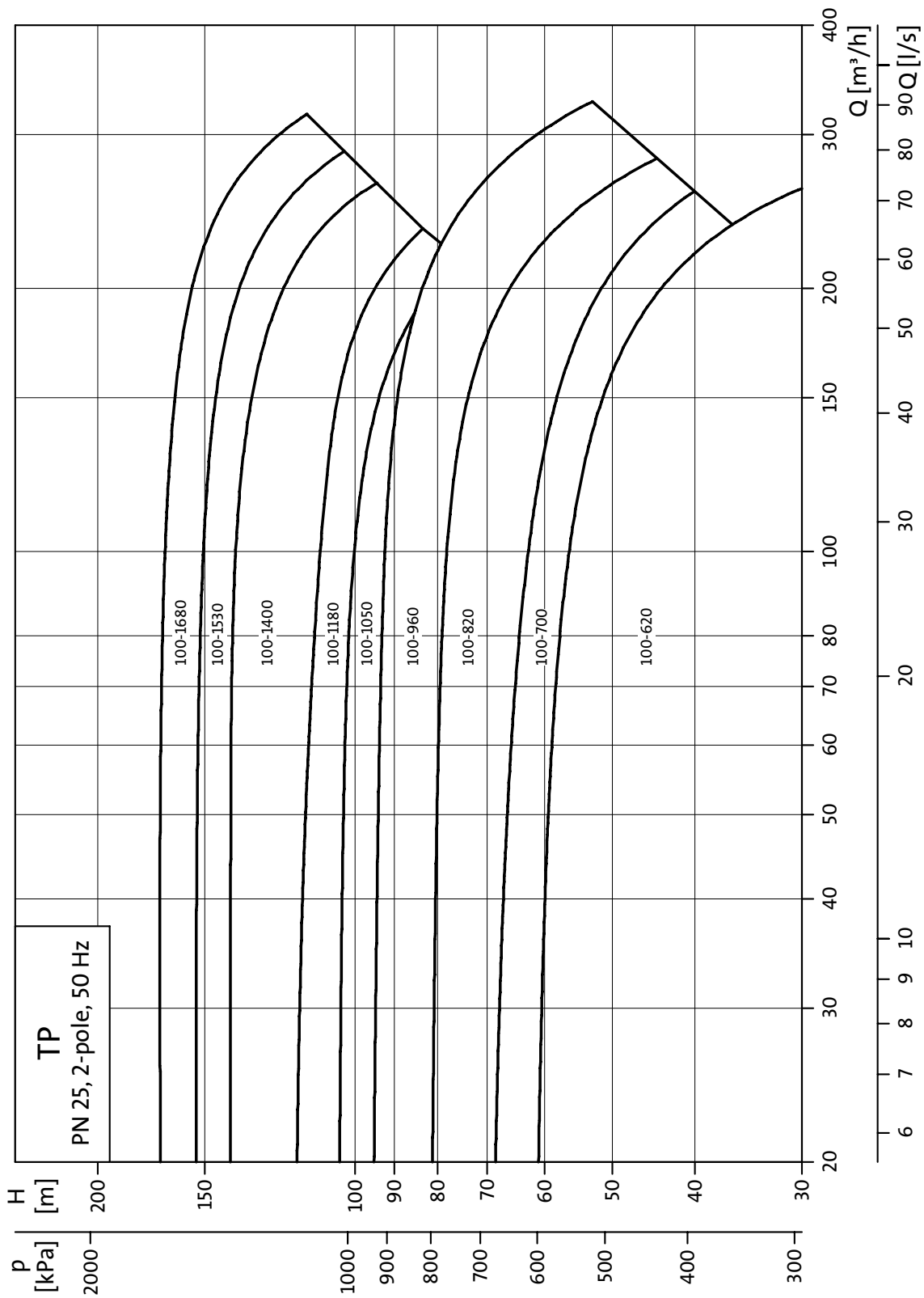

TM02 6866 3006

## Performance range, 4-pole, PN 25

(See page 104 for performance curves)

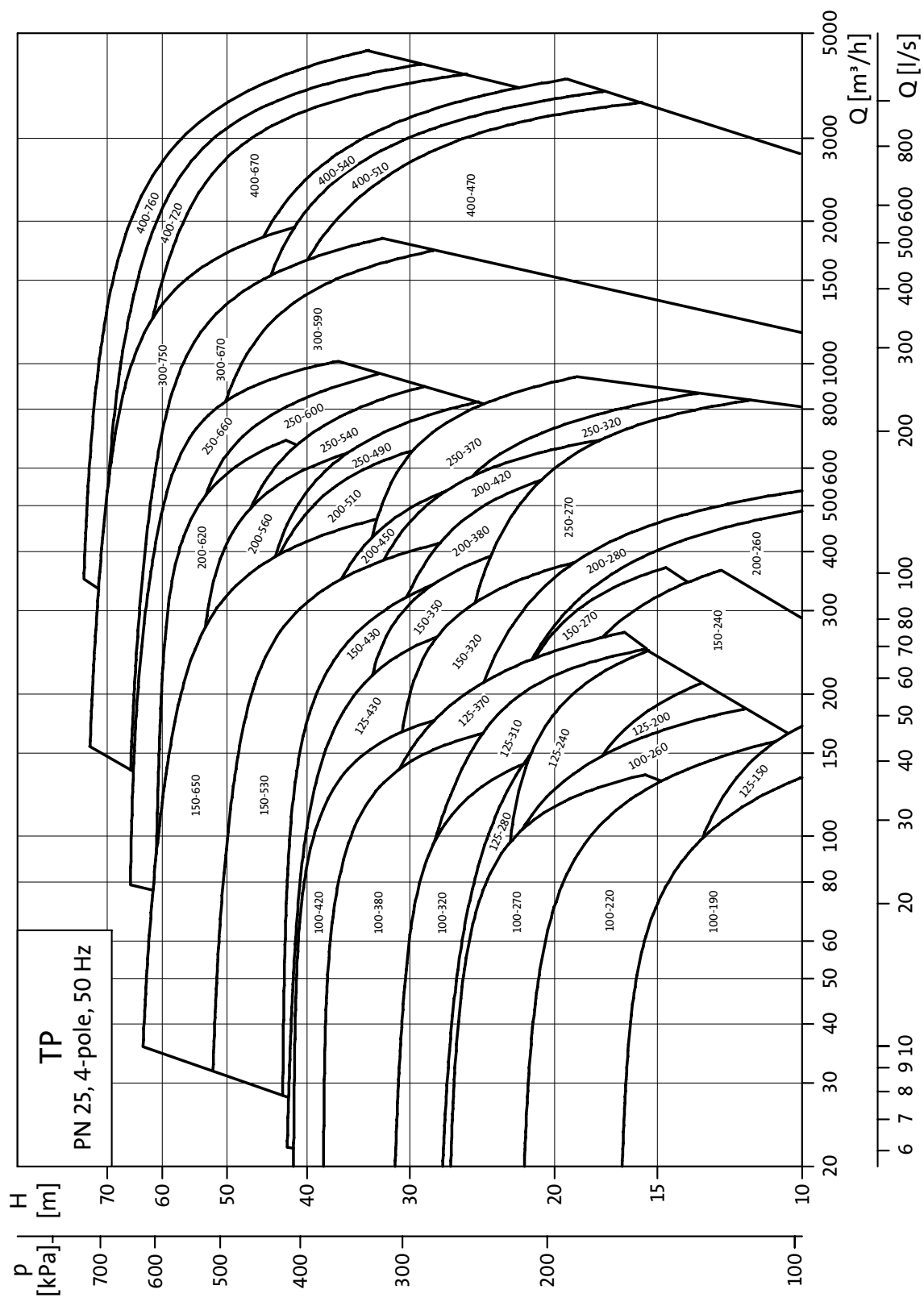

TM02 6869 1304

## Product range, 2-pole, 6, 10, 16

Pump type	Design					Shaft seal					Pressure stage				Materials					Mains-operated motor			Electronically speed-controlled motor								
	TPE Series 1000	TPE Series 2000	TP Series 100	TP Series 200	TP Series 300	TP Series 400	BUBE	AUUE	RUUE	BAGE	BQQE	GQQE	DBUE	PN 6	PN 10	PN 16	PN 25	Pump housing			Impeller		Voltage [V]			Voltage [V]					
																		Cast iron EN-GJL-250	Nodular cast iron EN-GJS-400-18	Bronze (1)	Stainless steel	Cast iron	Nodular cast iron EN-GJS-400-15	Bronze	1 x 220-230 ΔV/ 240 YV	P <sub>2</sub> [kW]	P <sub>2</sub> [kW]	P <sub>2</sub> [kW]	1 x 220-240 V	P <sub>2</sub> [kW]	P <sub>2</sub> [kW]
TP 25-50/2 R	●					●																	0.12	0.12		0.37					
TP 25-90/2 R	●					●																		0.25	0.25		0.37				
TP 32-50 /2 R	●					●																		0.12	0.12		0.37				
TP 32-90/2 R	●					●																		0.25	0.25		0.37				
TP, TPD 32-60/2	●	●				●	●	●						●	●									0.25	0.18		0.37				
TP, TPD 32-120/2	●	●				●	●	●					●	●										0.25	0.37		0.37				
TP, TPD 32-150/2	●	●				●	●	●					●	●										0.37	0.37		0.37				
TP, TPD 32-180/2	●	●				●	●	●					●	●										0.55	0.55		0.55				
TP, TPD 32-230/2	●	●				●	●	●					●	●										0.75	0.75		0.75	0.75			
TP, TPD 32-200/2	●	●				●			●	●	●				●						●			1.1	1.1		1.1	1.1			
TP, TPD 32-250/2	●	●				●			●	●	●				●						●			1.5	1.5			1.5			
TP, TPD 32-320/2	●	●				●			●	●	●				●						●				2.2	2.2		2.2			
TP, TPD 32-380/2	●	●				●			●	●	●				●						●				3.0	3.0		3.0			
TP, TPD 32-460/2	●	●				●			●	●	●				●						●				4.0	4.0		4.0			
TP, TPD 32-580/2	●	●				●			●	●	●				●						●				5.5	5.5		5.5			
TP 40-50/2	●		●				●						●	●										0.12	0.12		0.37				
TP, TPD 40-60/2	●	●				●	●	●					●	●										0.25	0.25		0.37				
TP 40-90/2	●		●				●						●	●										0.25	0.25		0.37				
TP, TPD 40-120/2	●	●				●	●	●					●	●										0.37	0.37		0.37				
TP 40-180/2	●		●				●	●					●	●										0.55	0.55		0.55				
TP, TPD 40-190/2	●	●				●	●	●					●	●										0.75	0.75		0.75	0.75			
TP, TPD 40-230/2	●	●				●	●	●					●	●										1.1	1.1		1.1	1.1			
TP, TPD 40-270/2	●	●				●	●	●					●	●										1.5	1.5			1.5			
TP, TPD 40-240/2	●	●				●			●	●	●				●						●				2.2	2.2		2.2			
TP, TPD 40-300/2	●	●				●			●	●	●				●						●				3.0	3.0		3.0			
TP, TPD 40-360/2	●	●				●			●	●	●				●						●				4.0	4.0		4.0			
TP, TPD 40-470/2	●	●				●			●	●	●				●						●				5.5	5.5		5.5			
TP, TPD 40-580/2	●	●				●			●	●	●				●						●				7.5	7.5		7.5			
TP, TPD 50-60/2	●	●				●	●	●					●	●										0.25	0.37		0.37				
TP, TPD 50-120/2	●	●				●	●	●					●	●										0.55	0.75		0.75	0.75			
TP, TPD 50-180/2	●	●				●	●	●					●	●										0.75	0.75		0.75	0.75			
TP, TPD 50-160/2	●	●				●			●	●	●				●						●			1.1	1.1		1.1	1.1			
TP, TPD 50-190/2	●	●				●			●	●	●				●						●			1.5	1.5			1.5			
TP, TPD 50-240/2	●	●				●			●	●	●				●						●				2.2	2.2		2.2			
TP, TPD 50-290/2	●	●				●			●	●	●				●						●				3.0	3.0		3.0			
TP, TPD 50-360/2	●	●				●			●	●	●				●						●				4.0	4.0		4.0			
TP, TPD 50-430/2	●	●				●			●	●	●				●						●				5.5	5.5		5.5			
TP, TPD 50-440/2	●	●				●			●	●	●				●						●				7.5	7.5		7.5			
TP, TPD 50-570/2	●	●				●			●	●	●				●						●				11.0	11.0		11.0			
TP, TPD 50-710/2	●	●				●			●	●	●				●						●				15.0	15.0		15.0			
TP, TPD 50-830/2	●	●				●			●	●	●				●						●				18.5	18.5		18.5			
TP, TPD 50-900/2	●	●				●			●	●	●				●						●				22.0	22.0		22.0			
TP, TPD 65-60/2	●	●				●	●	●					●	●										0.55	0.55		0.55				
TP, TPD 65-120/2	●	●				●	●	●					●	●										1.1	1.1		1.1	1.1			
TP, TPD 65-180/2	●	●				●	●	●					●	●										1.5	1.5			1.5			
TP, TPD 65-190/2	●	●				●			●	●	●				●						●				2.2	2.2		2.2			
TP, TPD 65-230/2	●	●				●			●	●	●				●						●				3.0	3.0		3.0			
TP, TPD 65-260/2	●	●				●			●	●	●				●						●				4.0	4.0		4.0			
TP, TPD 65-340/2	●	●				●			●	●	●				●						●				5.5	5.5		5.5			

# Product range

TP, TPD, TPE, TPED

Pump type	Design				Shaft seal				Pressure stage				Materials				Mains-operated motor			Electronically speed-controlled motor										
	TPE Series 1000	TPE Series 2000	TP Series 100	TP Series 200	TP Series 300	TP Series 400	BUBE	AUUE	RUUE	BAQE	BQQE	GQQE	DBUE	PN 6	PN 10	PN 16	PN 25	Pump housing		Impeller		Voltage [V]			Voltage [V]					
																		Cast iron EN-GJL-250	Nodular cast iron EN-GJS-400-18	Bronze (1)	Stainless steel	Cast iron	Nodular cast iron EN-GJS-400-15	Bronze	P <sub>2</sub> [kW]	P <sub>2</sub> [kW]	P <sub>2</sub> [kW]	P <sub>2</sub> [kW]	P <sub>2</sub> [kW]	P <sub>2</sub> [kW]
TP, TPD 65-410/2	●	●		●					●	●	●				●	●	●						7.5	7.5		7.5				
TP, TPD 65-460/2	●	●		●					●	●	●				●	●	●						11.0	11.0		11.0				
TP, TPD 65-550/2	●	●		●					●	●	●				●	●	●						15.0	15.0		15.0				
TP, TPD 65-660/2	●	●		●					●	●	●				●	●	●						18.5	18.5		18.5				
TP, TPD 65-720/2	●	●		●					●	●	●				●	●	●						22.0	22.0		22.0				
TP, TPD 65-930/2				●					●	●	●				●	●	●						30.0	30.0						
TP, TPD 80-120/2	●	●	●			●	●	●					●	●			●			●	●		1.1	1.5		1.5				
TP, TPD 80-140/2	●	●		●					●	●	●				●	●	●						2.2	2.2		2.2				
TP, TPD 80-180/2	●	●		●					●	●	●				●	●	●						3.0	3.0		3.0				
TP, TPD 80-210/2	●	●		●					●	●	●				●	●	●						4.0	4.0		4.0				
TP, TPD 80-240/2	●	●		●					●	●	●				●	●	●						5.5	5.5		5.5				
TP, TPD 80-250/2	●	●		●					●	●	●				●	●	●						7.5	7.5		7.5				
TP, TPD 80-330/2	●	●		●					●	●	●				●	●	●						11.0	11.0		11.0				
TP, TPD 80-400/2	●	●		●					●	●	●				●	●	●						15.0	15.0		15.0				
TP, TPD 80-520/2	●	●		●					●	●	●				●	●	●						18.5	18.5		18.5				
TP, TPD 80-570/2	●	●		●					●	●	●				●	●	●						22.0	22.0		22.0				
TP, TPD 80-700/2				●					●	●	●				●	●	●						30.0	30.0						
TP, TPD 100-120/2	●	●	●			●	●	●					●	●			●			●	●		2.2	2.2		2.2				
TP, TPD 100-160/2	●	●		●					●	●	●				●	●	●						4.0	4.0		4.0				
TP, TPD 100-200/2	●	●		●					●	●	●				●	●	●						5.5	5.5		5.5				
TP, TPD 100-240/2	●	●		●					●	●	●				●	●	●						7.5	7.5		7.5				
TP, TPD 100-250/2	●	●		●					●	●	●				●	●	●						11.0	11.0		11.0				
TP, TPD 100-310/2	●	●		●					●	●	●				●	●	●						15.0	15.0		15.0				
TP, TPD 100-360/2	●	●		●					●	●	●				●	●	●						18.5	18.5		18.5				
TP, TPD 100-390/2	●	●		●					●	●	●				●	●	●						22.0	22.0		22.0				
TP, TPD 100-480/2				●					●	●	●				●	●	●						30.0	30.0						

● Standard.

<sup>1)</sup> Bronze versions are only available as single-head pumps.

<sup>2)</sup> 2-pole motors above 11 kW can be operated at 3 x 660-690 YV. Smaller motor sizes cannot.

## Product range, 4-pole, PN 6, 10, 16

Pump type	Design						Shaft seal						Pressure stage				Materials						Mains-operated motor			Electronically speed-controlled motor			
	TPE Series 1000	TPE Series 2000	TP Series 100	TP Series 200	TP Series 300	TP Series 400	BUBE	AUUE	RUUE	BAQE	BQQE	GQQE	DBUE	PN 6	PN 10	PN 16	PN 25	Pump housing			Impeller			Voltage [V]			Voltage [V]		
																		Cast iron EN-GJL-250	Nodular cast iron EN-GJS-400-18	Bronze (1)	Stainless steel	Cast iron	Nodular cast iron EN-GJS-400-15	Bronze	1 x 220-230 ΔV/240 YV	P <sub>2</sub> [kW]	P <sub>2</sub> [kW]	P <sub>2</sub> [kW]	1 x 220-240 V
TP, TPD 32-30/4	●	●					●	●						●				●						0.12	0.12		0.37		
TP, TPD 32-40/4	●	●					●	●						●				●						0.18	0.25		0.37		
TP, TPD 32-60/4	●	●					●	●						●				●						0.18	0.25		0.37		
TP, TPD 32-80/4	●	●			●					●	●	●					●	●						0.25	0.25		0.37		
TP, TPD 32-100/4	●	●			●					●	●	●					●	●						0.37	0.37		0.37		
TP, TPD 32-120/4	●	●			●					●	●	●					●	●						0.55	0.55		0.55		
TP, TPD 40-30/4	●	●		●			●	●	●					●				●	●					0.12	0.12		0.37		
TP 40-60/4	●	●		●			●	●	●					●				●	●					0.25	0.25		0.37		
TP, TPD 40-90/4	●	●		●			●	●	●					●				●	●					0.18	0.25		0.37		
TP, TPD 40-100/4	●	●		●					●	●	●						●	●						0.55	0.55		0.55	0.55	
TP, TPD 40-130/4	●	●		●					●	●	●						●	●						0.75	0.75		0.75	0.75	
TP, TPD 40-160/4	●	●		●					●	●	●						●	●						1.1	1.1			1.1	
TP, TPD 50-30/4	●	●		●			●	●	●					●				●	●					0.18	0.25		0.37		
TP, TPD 50-60/4	●	●		●			●	●	●					●				●	●					0.37	0.37		0.37		
TP, TPD 50-90/4	●	●		●					●	●	●						●	●						0.55	0.55		0.55	0.55	
TP, TPD 50-110/4	●	●		●					●	●	●						●	●						0.75	0.75		0.75	0.75	
TP, TPD 50-130/4	●	●		●					●	●	●						●	●						1.1	1.1			1.1	
TP, TPD 50-160/4	●	●		●					●	●	●						●	●						1.5	1.5			1.5	
TP, TPD 50-190/4	●	●		●					●	●	●						●	●							2.2	2.2		2.2	
TP, TPD 50-230/4	●	●		●					●	●	●						●	●							3.0	3.0		3.0	
TP, TPD 65-30/4	●	●		●			●	●	●					●				●	●					0.25	0.25		0.37		
TP, TPD 65-60/4	●	●		●			●	●	●					●				●	●					0.55	0.55		0.55	0.55	
TP, TPD 65-90/4	●	●		●					●	●	●						●	●						0.75	0.75		0.75	0.75	
TP, TPD 65-110/4	●	●		●					●	●	●						●	●						1.1	1.1			1.1	
TP, TPD 65-130/4	●	●		●					●	●	●						●	●						1.5	1.5			1.5	
TP, TPD 65-150/4	●	●		●					●	●	●						●	●							2.2	2.2		2.2	
TP, TPD 65-170/4	●	●		●					●	●	●						●	●							3.0	3.0		3.0	
TP, TPD 65-240/4	●	●		●					●	●	●						●	●							4.0	4.0		4.0	
TP, TPD 80-30/4	●	●		●			●	●	●					●				●	●					0.37	0.37		0.37		
TP, TPD 80-60/4	●	●		●			●	●	●					●				●	●					0.75	0.75		0.75	0.75	
TP, TPD 80-70/4	●	●		●					●	●	●						●	●						1.1	1.1			1.1	
TP, TPD 80-90/4	●	●		●					●	●	●						●	●						1.5	1.5			1.5	
TP, TPD 80-110/4	●	●		●					●	●	●						●	●							2.2	2.2		2.2	
TP, TPD 80-150/4	●	●		●					●	●	●						●	●							3.0	3.0		3.0	
TP, TPD 80-170/4	●	●		●					●	●	●						●	●							4.0	4.0		4.0	
TP, TPD 80-240/4	●	●		●					●	●	●						●	●							5.5	5.5		5.5	
TP, TPD 80-270/4	●	●		●					●	●	●						●	●							7.5	7.5		7.5	
TP, TPD 80-340/4	●	●		●					●	●	●						●	●							11.0	11.0		11.0	
TP, TPD 100-30/4	●	●		●			●	●	●					●				●	●					0.55	0.55		0.55	0.55	
TP, TPD 100-60/4	●	●		●			●	●	●					●				●	●					1.1	1.1			1.1	
TP, TPD 100-70/4	●	●		●					●	●	●						●	●						1.5	1.5			1.5	
TP, TPD 100-90/4	●	●		●					●	●	●						●	●							2.2	2.2		2.2	
TP, TPD 100-110/4	●	●		●					●	●	●						●	●							3.0	3.0		3.0	
TP, TPD 100-130/4	●	●		●					●	●	●						●	●							4.0	4.0		4.0	
TP, TPD 100-170/4	●	●		●					●	●	●						●	●							5.5	5.5		5.5	
TP, TPD 100-200/4	●	●		●					●	●	●						●	●							7.5	7.5		7.5	
TP, TPD 100-250/4	●	●		●					●	●	●						●	●							11.0	11.0		11.0	
TP, TPD 100-330/4	●	●		●					●	●	●						●	●							15.0	15.0		15.0	
TP, TPD 100-370/4	●	●		●					●	●	●						●	●							18.5	18.5		18.5	



## Product range, 6-pole, PN 16

Pump type	Design				Shaft seal				Pressure stage				Materials				Mains-operated motor			Electronically speed-controlled motor																
													Pump housing		Impeller		Voltage [V]			Voltage [V]																
	TPE Series 1000	TPE Series 2000	TP Series 100	TP Series 200	TP Series 300	TP Series 400	BUBE	AUUE	RUUE	BAGQ	BQQE	GQQE	DBUE	PN 6	PN 10	PN 16	PN 25	Cast iron EN-GJL-250	Nodular cast iron EN-GJS-400-18	Bronze (1)	Stainless steel	Cast iron	Nodular cast iron EN-GJS-400-15	Bronze	1 x 220-230 ΔV/ 240 YV	P <sub>2</sub> [kW]	3 x 220-240 ΔV/ 380-415 YV	P <sub>2</sub> [kW]	3 x 380-415 ΔV/ 660-690 YV	P <sub>2</sub> [kW]	1 x 220-240 V	P <sub>2</sub> [kW]	3 x 380-480 V	P <sub>2</sub> [kW]	3 x 380-415 V	P <sub>2</sub> [kW]
TP, TPD 125-60/6				●					●	●	●						●				●					1.5										
TP, TPD 125-70/6				●					●	●	●						●				●						2.2	2.2								
TP, TPD 125-90/6				●					●	●	●						●				●						3.0	3.0								
TP, TPD 125-110/6				●					●	●	●						●				●						4.0	4.0								
TP, TPD 125-140/6				●					●	●	●						●				●						5.5	5.5								
TP, TPD 125-170/6				●					●	●	●						●				●						7.5	7.5								
TP, TPD 150-60/6				●					●	●	●						●				●						2.2	2.2								
TP, TPD 150-70/6				●					●	●	●						●				●						3.0	3.0								
TP, TPD 150-90/6				●					●	●	●						●				●						4.0	4.0								
TP, TPD 150-110/6				●					●	●	●						●				●						5.5	5.5								

● Standard.

<sup>1</sup> Bronze versions are only available as single-head pumps.

## Product range, 2-pole, PN 25

Pump type	Design				Shaft seal				Pressure stage				Materials				Mains-operated motor			Electronically speed-controlled motor																			
													Pump housing		Impeller		Voltage [V]			Voltage [V]																			
	TPE Series 1000	TPE Series 2000	TP Series 100	TP Series 200	TP Series 300	TP Series 400	BUBE	AUUE	RUUE	BAGQ	BQQE	GQQE	DBUE	PN 6	PN 10	PN 16	PN 25	Cast iron EN-GJL-250	Nodular cast iron EN-GJS-400-18	Bronze	Stainless steel	Cast iron	Nodular cast iron EN-GJS-400-15	Bronze	1 x 220-230 ΔV/ 240 YV	P <sub>2</sub> [kW]	3 x 220-240 ΔV/ 380-415 YV	P <sub>2</sub> [kW]	3 x 380-415 ΔV/ 660-690 YV	P <sub>2</sub> [kW]	1 x 220-240 V	P <sub>2</sub> [kW]	3 x 380-480 V	P <sub>2</sub> [kW]	3 x 380-415 V	P <sub>2</sub> [kW]			
TP 100-620/2				●								●						●				●																	37.0
TP 100-700/2				●								●						●				●																	45.0
TP 100-820/2				●								●						●				●																	55.0
TP 100-960/2				●								●						●				●																	75.0
TP 100-1050/2				●								●						●				●																	75.0
TP 100-1180/2				●								●						●				●																	90.0
TP 100-1400/2				●								●						●				●																	110.0
TP 100-1530/2				●								●						●				●																	132.0
TP 100-1680/2				●								●						●				●																	160.0

● Standard.



## System and test pressures

Pressure	System pressure		Test pressure	
	[bar]	[MPa]	[bar]	[MPa]
PN 6	6	0.6	10	1.0
PN 10	10	1.0	16	1.6
PN 16	16	1.6	24	2.4
PN 25	25	2.5	38	3.8

## Sound pressure level

Single-phase: Max. 70 dB(A).  
 Three-phase: See table below.

Motor [kW]	Maximum sound pressure level [dB(A)] - ISO 3743		
	Three-phase motors		
	2-pole	4-pole	6-pole
0.12	-	-	-
0.18	-	-	-
0.25	56	41	-
0.37	56	45	-
0.55	57	42	-
0.75	56	42	-
1.1	52	50	-
1.5	58	50	47
2.2	60	52	52
3.0	59	52	63
4.0	63	54	63
5.5	63	51	63
7.5	60	52	66
11.0	60	54	-
15.0	60	54	-
18.5	60	63	-
22.0	64	63	-
30.0	71	65	-
37.0	71	66	-
45.0	71	66	-
55.0	71	67	-
75.0	73	70	-
90.0	73	70	-
110.0	76	70	-
132.0	76	70	-
160.0	76	70	-
200.0	-	70	-
250.0	-	73	-
315.0	-	73	-
355.0	-	75	-
400.0	-	75	-
500.0	-	75	-
560.0	-	78	-
630.0	-	78	-

The values apply only to MG and Siemens motors.

The values have a tolerance of 3 dB according to EN ISO 4871; the tolerance is not added to the values in the table.

The audible noise from TP pumps is primarily noise from the motor fan. The selection of TPE pumps will reduce the noise at partial load, as the motor, and consequently, the motor fan runs at a lower speed. Possible flow noise from control valves is also reduced at partial load in the case of the TPE pump.

## Ambient temperature

MG – EFF1-motors: 1.1 - 22 kW motors, 2-pole 1.1 - 15 kW, 4-pole	-30 to +60 °C
Siemens – EFF1-motors: 30 - 90 kW motors, 2-pole 18.5 - 90 kW motors, 4-pole	-30 to +55 °C
MGE and other motor sizes:	-30 to +40 °C
Storage:	Down to -30 °C

If the ambient temperature exceeds above maximum values or if the motor is located more than 1000 metres above sea level, the motor output ( $P_2$ ) must be reduced due to the low density and consequent low cooling effect of the air. In such cases, it may be necessary to use an oversize motor with a higher rated output.

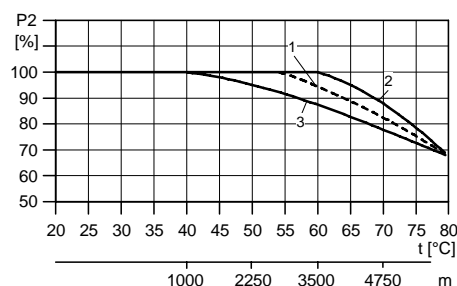

Fig. 1 Relationship between motor output ( $P_2$ ) and altitude

### Key

Pos	Description
1	Siemens – EFF1-motors: 30 - 90 kW motors, 2-pole 18.5 - 90 kW motors, 4-pole
2	MG – EFF1-motors: 1.1 - 22 kW motors, 2-pole 1.1 - 15 kW, 4-pole
3	MGE and other motor sizes

TM03 2479 4405

## Pumped liquids

Thin, clean, non-aggressive and non-explosive liquids, not containing solid particles or fibres that may mechanically or chemically attack the pump, please see "List of pumped liquids" on page 19.

### Examples of liquids:

- central heating system water (the water should meet the requirements of accepted standards on water quality in heating systems)
- cooling liquids
- domestic hot water
- industrial liquids
- softened water.

If glycol or another antifreeze agent is added to the pumped liquid, the pump must have a shaft seal of the type RUUE or GQQE.

The pumping of liquids with densities or kinematic viscosities higher than those of water can cause

- a considerable pressure drop
- a drop in the hydraulic performance
- a rise in the power consumption.

In these situations, equip the pump with an oversize motor. If in doubt, contact Grundfos.

If the water contains mineral oils or chemicals, or if other liquids than water are pumped, the O-rings should be chosen accordingly.

## Liquid temperature

Liquid temperature: -25 °C to +150 °C.

Please note that shaft seals operating close to their maximum temperature will require regular maintenance, i.e. replacement.

Pump type	Shaft seal	Temperature
TP Series 100	BUBE	0 °C to +110 °C
	BQQE	0 °C to +90 °C
	GQQE	-25 °C to +90 °C
TP Series 200	BUBE	0 °C to +140 °C
	AUUE	0 °C to +90 °C
	RUUE	-25 °C to +90 °C
TP Series 300	BAQE	0 °C to +120 °C (140 °C) <sup>1)</sup>
	BQQE	0 °C to +90 °C
	GQQE	-25 °C to +90 °C (60 °C) <sup>2)</sup>
TP Series 400, 10 bar version	BAQE	0 °C to +120 °C
	BQQE	0 °C to +90 °C
	GQQE	-25 °C to +90 °C
TP Series 400, 25 bar version	DBUE	0 °C to +150 °C <sup>3)</sup>

<sup>1)</sup> TP Series 300 pumps are designed for a maximum operating temperature of 140 °C. For operation above 120 °C, an alternative shaft seal is to be selected. Contact Grundfos.

<sup>2)</sup> The below listed TP Series 300 pumps with GQQE shaft seals are designed for a maximum operating temperature of 60 °C.

TP 150-260/4	TP 200-180/4
TP 150-280/4	TP 200-220/4
TP 150-340/4	TP 200-250/4
TP 150-390/4	TP 200-270/4
	TP 200-320/4
	TP 200-330/4
	TP 200-360/4
	TP 200-400/4
	TP 200-410/4
	TP 200-470/4
	TP 200-530/4
	TP 200-590/4
	TP 200-660/4

<sup>3)</sup> At +120 to +150 °C, the maximum operating pressure ≤ 23 bar.

Depending on the type of cast iron used and the pump application, the maximum liquid temperature may be limited by local regulations and laws.

## List of pumped liquids

Grundfos TP and TPD pumps are designed for circulation systems with constant flow; TPE and TPED pumps for systems with variable flow.

Thanks to their design, the pumps can be used in a wider liquid temperature range than pumps of the canned rotor type.

A number of typical liquids are listed below.

Other pump versions may be used, but we consider the ones stated in the list to be the best choices.

The list is intended as a general guide only, and it cannot replace actual testing of the pumped liquids and pump materials under specific working conditions. If in doubt, contact Grundfos.

Use the list with some caution, as factors such as concentration of the pumped liquid, liquid temperature or pressure may affect the chemical resistance of a specific pump version.

### Legend

<b>A</b>	May contain additives or impurities that may cause shaft seal problems.
<b>B</b>	The density and/or viscosity differ from those of water. Consider this when calculating motor and pump performance.
<b>C</b>	The liquid must be oxygen-free (anaerobic).
<b>D</b>	Risk of crystallisation/precipitation in the shaft seal.
<b>E</b>	Insoluble in water.
<b>F</b>	The shaft seal rubber parts must be replaced with FKM rubber.
<b>G</b>	Bronze housing/impeller required.
<b>H</b>	Risk of formation of ice on the standby pump. (The risk only applies to TP, TPE Series 200 pumps.)

Pumped liquids	Notes	Additional information	Shaft seal				
			TP Series 100	TP Series 200	TP Series 300	TP Series 400 PN 10	TP Series 400 PN 25
<b>Water</b>							
Groundwater		< +90 °C	BQQE	AUUE	BQQE		
		> +90 °C	BUBE	BUBE	BAQE <sup>1)</sup> BBQE <sup>3)</sup>	BAQE	DBUE
Boiler-feed water		< +120 °C	BUBE <sup>4)</sup>	BUBE	BAQE	BAQE	DBUE
		< +140 °C		BUBE	BQBE/DAQF <sup>3)</sup>		DBUE
		< +150 °C					DBUE
District heating water		< +120 °C	BUBE	BUBE	BAQE	BAQE	DBUE
Condensate		< +90 °C	BQQE	AUUE	BQQE		
		> +90 °C	BUBE	BUBE	BAQE	BAQE	DBUE
Softened water	C	< +90 °C	BQQE	AUUE	BQQE		
		> +90 °C	BUBE	BUBE	BAQE	BAQE	DBUE
Brackish water	G	pH > 6.5, +40 °C, 1000 ppm Cl <sup>-</sup>	BUBE	BUBE	BQQE	BQQE	DBUE
			BQQE	AUUE			
<b>Coolants</b>							
Ethylene glycol	B, D, H	< +50 °C, 50 %	BQQE GQQE	AUUE RUUE	BAQE <sup>2)</sup> BQQE GQQE	GQQE	DQQE <sup>3)</sup>
Glycerine (glycerol)	B, D, H	< +50 °C, 50 %	BQQE GQQE	AUUE RUUE	BQQE GQQE	GQQE	DQQE <sup>3)</sup>
Potassium acetate	B, D, C, H	< +50°C, 50%	BQQE GQQE	AUUE RUUE	BQQE GQQE	GQQE	DQQE <sup>3)</sup>
Potassium formate	B, D, C, H	< +50 °C, 50 %	BQQE GQQE	AUUE RUUE	BQQE GQQE	GQQE	DQQE <sup>3)</sup>
Propylene glycol	B, D, H		BQQE GQQE	AUUE RUUE	BAQE <sup>2)</sup> BQQE GQQE	GQQE	DQQE <sup>3)</sup>
Brine-sodium chloride	B, D, C, H	< +5 °C, 30 %	BQQE GQQE	AUUE RUUE	BQQE GQQE	GQQE	DQQE <sup>3)</sup>
<b>Synthetic oils</b>							
Silicone oil	B, E		BUBE BQQE	BUBE AUUE	BAQE BQQE	BAQE	DBUE

(To be continued)

Pumped liquids	Notes	Additional information	Shaft seal				
			TP Series 100	TP Series 200	TP Series 300	TP Series 400 PN 10	TP Series 400 PN 25
<b>Vegetable oils</b>							
Corn oil	B, F, E		BUBV <sup>3)</sup> BQQV <sup>3)</sup>	BUBV <sup>3)</sup> AUUV <sup>3)</sup>	BAQV <sup>3)</sup> BQQV <sup>3)</sup>	BAQV <sup>3)</sup>	DBUV <sup>3)</sup>
Olive oil	B, F, E	< +80 °C	BUBV <sup>3)</sup> BQQV <sup>3)</sup>	BUBV <sup>3)</sup> AUUV <sup>3)</sup>	BAQV <sup>3)</sup> BQQV <sup>3)</sup>	BAQV <sup>3)</sup>	DBUV <sup>3)</sup>
Peanut oil	B, F, E		BUBV <sup>3)</sup> BQQV <sup>3)</sup>	BUBV <sup>3)</sup> AUUV <sup>3)</sup>	BAQV <sup>3)</sup> BQQV <sup>3)</sup>	BAQV <sup>3)</sup>	DBUV <sup>3)</sup>
Rape seed oil	D, B, F, E		BUBV <sup>3)</sup> BQQV <sup>3)</sup>	BUBV <sup>3)</sup> AUUV <sup>3)</sup>	BAQV <sup>3)</sup> BQQV <sup>3)</sup>	BAQV <sup>3)</sup>	DBUV <sup>3)</sup>
Soya bean oil	B, F, E		BUBV <sup>3)</sup> BQQV <sup>3)</sup>	BUBV <sup>3)</sup> AUUV <sup>3)</sup>	BAQV <sup>3)</sup> BQQV <sup>3)</sup>	BAQV <sup>3)</sup>	DBUV <sup>3)</sup>
<b>Cleaning agents</b>							
Soap (salts of fatty acids)	A, E, (F)	< +80 °C	BQQE (BQQV) <sup>3)</sup>	AUUE (AUUV) <sup>3)</sup>	BQQE (BQQV) <sup>3)</sup>	GQQE	DQQE <sup>3)</sup>
Alkaline degreasing agent	A, E, (F)	< +80 °C	BQQE (BQQV) <sup>3)</sup>	AUUE (AUUV) <sup>3)</sup>	BQQE (BQQV) <sup>3)</sup>	GQQE	DQQE <sup>3)</sup>
<b>Oxidants</b>							
Hydrogen peroxide		< +40 °C, <2 %	BUBE BQQE	BUBE AUUE	BQQE	BQQV <sup>3)</sup>	DQQE <sup>3)</sup>
<b>Salts</b>							
Ammonium bicarbonate	A	< +20 °C, <15 %	BQQE	AUUE	BQQE	GQQE	DQQE <sup>3)</sup>
Calcium acetate	A, B	< +20 °C, <30 %	BQQE	AUUE	BQQE	GQQE	DQQE <sup>3)</sup>
Potassium bicarbonate	A	< +20 °C, <20 %	BQQE	AUUE	BQQE	GQQE	DQQE <sup>3)</sup>
Potassium carbonate	A	< +20 °C, <20 %	BQQE	AUUE	BQQE	GQQE	DQQE <sup>3)</sup>
Potassium permanganate	A	< +20 °C, <10 %	BQQE	AUUE	BQQE	GQQE	DQQE <sup>3)</sup>
Potassium sulphate	A	< +20 °C, <20 %	BQQE	AUUE	BQQE	GQQE	DQQE <sup>3)</sup>
Sodium acetate	A	< +20 °C, <100 %	BQQE	AUUE	BQQE	GQQE	DQQE <sup>3)</sup>
Sodium bicarbonate	A	< +20 °C, <2 %	BQQE	AUUE	BQQE	GQQE	DQQE <sup>3)</sup>
Sodium carbonate	A	< +20 °C, <20 %	BQQE	AUUE	BQQE	GQQE	DQQE <sup>3)</sup>
Sodium nitrate	A	< +20 °C, <40 %	BQQE	AUUE	BQQE	GQQE	DQQE <sup>3)</sup>
Sodium nitrite	A	< +20 °C, <40 %	BQQE	AUUE	BQQE	GQQE	DQQE <sup>3)</sup>
Sodium phosphate (di)	A	< +100 °C, <30 %	BQQE	AUUE	BQQE	GQQE	DQQE <sup>3)</sup>
Sodium phosphate (tri)	A	< +90 °C, <20 %	BQQE	AUUE	BQQE	GQQE	DQQE <sup>3)</sup>
Sodium sulphate	A	< +20 °C, <20 %	BQQE	AUUE	BQQE	GQQE	DQQE <sup>3)</sup>
Sodium sulphite	A	< +20 °C, <1 %	BQQE	AUUE	BQQE	GQQE	DQQE <sup>3)</sup>
<b>Alkalis</b>							
Ammonium hydroxide		< +100 °C, <30 %	BQQE	AUUE	BQQE	GQQE	DQQE <sup>3)</sup>
Calcium hydroxide	A	< +100 °C, <10 %	BQQE	AUUE	BQQE	GQQE	DQQE <sup>3)</sup>
Potassium hydroxide	A	< +20 °C, <20 %	BQQE	AUUE	BQQE	GQQE	DQQE <sup>3)</sup>
Sodium hydroxide	A	< +40 °C, <20 %	BQQE	AUUE	BQQE	GQQE	DQQE <sup>3)</sup>

<sup>1)</sup> BAQE must **not** be used for potable water. For potable water, Grundfos recommends a BBQE shaft seal.

<sup>2)</sup> BAQE can be used in air-condition applications at temperatures above 0 °C.

<sup>3)</sup> The shaft seal is not standard, but available on request.

<sup>4)</sup> Maximum +110 °C.



GR8262 - GR8261

Fig. 2 TP Series 100 and TP Series 200

## Technical data

Flow rate: Up to 90 m<sup>3</sup>/h  
 Head: Up to 27 m  
 Liquid temperature (TP Series 100): -25 to +110 °C  
 Liquid temperature (TP Series 200): -25 to +140 °C  
 Maximum operating pressure: Up to 16 bar  
 Direction of rotation: Counter-clockwise

## Construction

Grundfos TP Series 100 and Series 200 pumps are single-stage, close-coupled pumps with in-line suction and discharge ports of identical diameter.

The pumps are equipped with a fan-cooled asynchronous motor. Motor and pump shafts are connected via a rigid two-part coupling.

TP Series 100 pumps with union connection are available as single-head (TP) pumps.

TP Series 200 pumps are available as single-head (TP) and twin-head (TPD) pumps.

TP Series 200 pumps have PN 6 or PN 10 flanges.

The pumps are equipped with an unbalanced mechanical shaft seal.

The pumps are of the top-pull-out design, i.e. the power head (motor, pump head and impeller) can be removed for maintenance or service while the pump housing remains in the pipework.

The twin-head pumps are designed with two parallel power heads. A non-return flap valve in the common discharge port is opened by the flow of the pumped liquid and prevents backflow of liquid into the idle pump head.

As radial and axial forces are absorbed by the fixed bearing in the motor drive-end, the pump requires no bearing.

TP, TPD Series 100 and 200 pumps are equipped with high-efficiency motors.

Pumps with bronze pump housing (version B) are suitable for circulation of domestic hot water.

## Materials

### TP Series 100

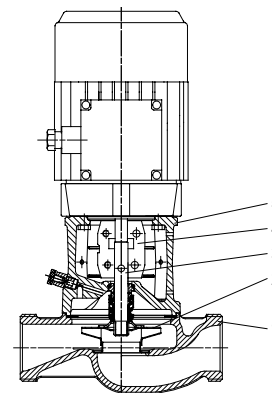

TM03 1210 1405

Fig. 3 Sectional drawing of TP Series 100 (with union connection)

### Material specification of Series 100

Pos.	Component	Material	EN/DIN
1	Pump housing	Cast iron EN-GJL-200, bronze CuSn10	EN-JL 1030 2.1093
2	Impeller	Stainless steel	1.4301
3	Shaft	Stainless steel	1.4057
4	Coupling	Cast iron EN-GJL-400	0.7040
5	Pump head	Cast iron EN-GJL-250, bronze	0.6025 2.1093
	Secondary seals	EPDM	
	Rotating seal face	Tungsten carbide Silicon carbide	
	Stationary seat	Carbon (resin-impregnated) Silicon carbide	

### TP, TPE Series 200

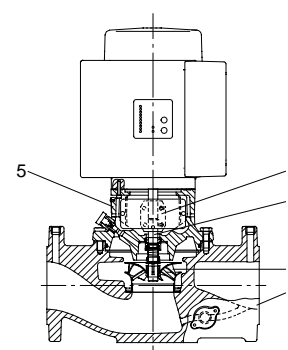

TM03 1211 1405

Fig. 4 Sectional drawing of TP Series 200 (with flange connection)

## Material specification of Series 200

Pos.	Component	Material	EN/DIN
1	Pump housing	Cast iron EN-GJL-250, bronze CuSn10	EN-JL 1040 2.1093
2	Impeller	Stainless steel	1.4301
3	Shaft	Stainless steel	1.4305
4	Coupling	Cast iron EN-GJL-400	0.7040
5	Pump head	Cast iron EN-GJL-250, bronze	0.6025 2.1093
	Secondary seals	EPDM	
	Rotating seal face	Tungsten carbide	
	Stationary seat	Carbon (resin-impregnated) Tungsten carbide	

## Mechanical shaft seal

Three types of unbalanced mechanical shaft seal are available as standard:

### • BUBE

The BUBE shaft seal is a Grundfos rubber bellows seal with tungsten carbide/carbon seal faces and secondary seals of EPDM.

### • RUUE/GQQE

The RUUE shaft seal is a Grundfos O-ring seal with reduced tungsten carbide/tungsten carbide seal faces and secondary seals of EPDM.

The GQQE shaft seal is a Grundfos rubber bellows seal with reduced silicon carbide/silicon carbide seal faces and secondary seals of EPDM.

### • AUUE/BQQE

The AUUE shaft seal is a Grundfos O-ring seal with fixed seal driver, tungsten carbide/tungsten carbide seal faces and secondary seals of EPDM.

The BQQE shaft seal is a Grundfos rubber bellows seal with silicon carbide/silicon carbide seal faces and secondary seals of EPDM.

Information on a selection of common pumped liquids with recommended shaft seals is shown on page 19.

## Shaft seal specification

Unbalanced shaft seal	TP Series 100	Version KU according to EN 12756
	TP, TPD Series 200	Version NU according to EN 12756
Shaft diameter	12 and 16 mm	
Rubber bellows	EPDM	
Seal faces	Tungsten carbide/carbon	
	Tungsten carbide/tungsten carbide	
	Silicon carbide/silicon carbide	

Special shaft seals are available for partly conditioned water or other liquids containing abrasive or crystallising particles. See page 19.

## Connections

TP Series 100 pumps with union connection have suction and discharge union threads to ISO 228-1.

TP Series 200 pumps up to DN 65 are equipped with combination flanges PN 6/PN 10. DN 80 or DN 100 pumps have either PN 6 or PN 10 flanges. All flanges can be connected to flanges in accordance with EN 1092-2 and ISO 7005-2.

## Features and benefits

TP Series 100 and Series 200 pumps have these features and benefits:

### Optimised hydraulics for high efficiency

- Reduced power consumption.

### High-efficiency motors

- TP pumps are fitted with high-efficiency motors. High-efficiency motors offer reduced energy consumption. 2-pole and 4-pole TP pumps from 1.1 kW have EFF1 motors.

### Top-pull-out design

- Easy dismantling in case of service.

### In-line design

- Contrary to end-suction pumps, in-line pumps allow a straight pipework and thus often reduced installation costs.

### Pump housing and pump head are electrocoated to improve the corrosion resistance

- Electrocoating includes:

1. Alkaline cleaning.
2. Pretreatment with zinc phosphate coating.
3. Cathodic electrocoating (epoxy).
4. Curing of paint film at 200-250 °C.

For low-temperature applications at a high humidity, Grundfos offers TP pumps with extra surface treatment to avoid corrosion. These pumps are available on request.

### Stainless steel impeller and neck ring

- Wear-free operation with high efficiency.

### TPE, TPED - pumps with built-in frequency converter

- 2-pole and 4-pole TP pumps from 0.37 and upwards are available as TPE pumps with built-in frequency converter. For further information, see pages 4 and 11-14.



Fig. 5 TP Series 300

GR8259

## Technical data

Flow rate:	Up to 825 m <sup>3</sup> /h
Head:	Up to 93 m
Liquid temperature:	-25 to +140 °C
Maximum operating pressure:	16 bar
Direction of rotation:	Clockwise

## Construction

Grundfos TP, TPD Series 300 pumps are single-stage, close-coupled pumps with in-line suction and discharge ports of identical diameter.

The pumps are equipped with a fan-cooled asynchronous motor. Motor and pump shafts are connected via a rigid sleeve coupling.

Most TP Series 300 pumps are available as single-head (TP) and twin-head (TPD) pumps.

TP Series 300 pumps have PN 16 flanges.

The pumps are equipped with an unbalanced mechanical shaft seal.

The pumps are of the top-pull-out design, i.e. the power head (motor, pump head and/or motor stool and impeller) can be removed for maintenance or service while the pump housing remains in the pipework.

The twin-head pumps are designed with two parallel power heads. A non-return flap valve in the common discharge port is opened by the flow of the pumped liquid and prevents backflow of liquid into the idle pump head.

As radial and axial forces are absorbed by the fixed bearing in the motor drive-end, the pump requires no bearing.

The impeller is hydraulically balanced to minimize axial forces.

TP, TPD Series 300 pumps are equipped with high-efficiency motors.

TP Series 300 pumps with bronze impeller are suitable for pumping brine.

## Materials

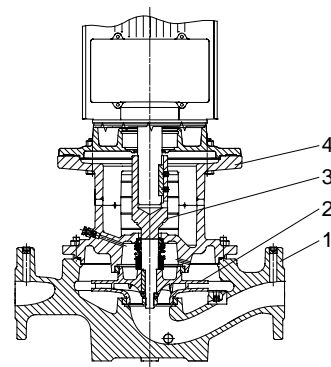

Fig. 6 Sectional drawing of TP Series 300

TM03 1212 1405

## Material specification

Pos.	Component	Material	EN/DIN
1	Pump housing	Cast iron EN-GJL-250	EN-JL 1040
2	Impeller	Cast iron EN-GJL-200, bronze CuSn5Zn5Pb	EN-JL 1030 2.1096.01
3	Stub shaft 2 part stub shaft	Stainless steel Stainless steel/steel	1.4301 1.4301/1.0301
4	Pump head/ motor stool	Cast iron EN-GJL-250	EN-JL 1040
	Secondary seals	EPDM	
	Rotating seal face	Metal-impregnated carbon Silicon carbide	
	Stationary seat	Silicon carbide	

## Mechanical shaft seal

Three types of unbalanced mechanical shaft seal are available as standard:

- BAQE**  
 The BAQE shaft seal is a Grundfos rubber bellows seal with carbon/silicon carbide seal faces and secondary seals of EPDM.
- GQQE**  
 The GQQE shaft seal is a Grundfos rubber bellows seal with reduced silicon carbide/silicon carbide seal faces and secondary seals of EPDM.
- BQQE**  
 The BQQE shaft seal is a Grundfos rubber bellows seal with silicon carbide/silicon carbide seal faces and secondary seals of EPDM.

Information on a selection of common pumped liquids with recommended shaft seals is shown on page 19.

## Shaft seal specification

Unbalanced shaft seal	Version NU according to EN 12756
Shaft diameter	28, 38, 48 and 55 mm
Rubber bellows	EPDM
Seal faces	Carbon/silicon carbide Silicon carbide/silicon carbide

Special shaft seals are available for partly conditioned water or other liquids containing abrasive or crystallising particles. See page 19.

## Connections

TP Series 300 pumps have PN 16 flanges.  
All dimensions are according to ISO 7005-2 or EN 1092-2.

## Features and benefits

TP Series 300 pumps have these features and benefits:

### Optimised hydraulics for high efficiency

- Reduced power consumption.

### High-efficiency motors

- TP pumps are fitted with high-efficiency motors. High-efficiency motors offer reduced energy consumption. 2-pole and 4-pole TP pumps from 1.1 kW to 90 kW have EFF1 motors.

### Top-pull-out design

- Easy dismantling in case of service.

### In-line design

- Contrary to end-suction pumps, in-line pumps allow a straight pipework and thus often reduced installation costs.

### Motor-pump shaft with sleeve coupling

- Stable and quiet operation.
- Easy dismantling in case of service.

### Hydraulically and mechanically balanced impeller

- The impeller is hydraulically and mechanically balanced to increase the life of motor bearings and shaft seal.

### Pump housing and pump head/motor stool are electrocoated to improve the corrosion resistance

- Electrocoating includes:
  1. Alkaline cleaning.
  2. Pretreatment with zinc phosphate coating.
  3. Cathodic electrocoating (epoxy).
  4. Curing of paint film at 200-250 °C.

For low-temperature applications at a high humidity, Grundfos offers TP pumps with extra surface treatment to avoid corrosion. These pumps are available on request.

### TPE, TPED - pumps with built-in frequency converter

- 2 pole TP pumps from 0.37 to 22 kW and 4 pole TP pumps from 0.37 to 18.5 kW are available as TPE pumps with built-in frequency converter.  
For further information, see page 4 and 11-14.



Fig. 7 TP Series 400

GR7539

## Technical data

Flow rate:	PN 10 version:	Up to 950 m <sup>3</sup> /h
	PN 25 version:	Up to 4500 m <sup>3</sup> /h
Head:	PN 10 version:	Up to 38 m
	PN 25 version:	Up to 170 m
Liquid temperature:	PN 10 version:	-25 to +120 °C
	PN 25 version:	0 to +150 °C *
	* From +120 to +150 °C, max. 23 bar	
Maximum operating pressure:	10 bar version:	10 bar
	25 bar version:	25 bar
Direction of rotation:	Clockwise	

## Construction

Grundfos TP Series 400 pumps are single-stage, close-coupled pumps with in-line suction and discharge ports.

The pumps are equipped with a fan-cooled asynchronous motor. Motor and pump shafts are connected via a rigid flange coupling.

TP Series 400 pumps are available as single-head (TP) pumps.

All TP Series 400 pumps have PN 10 or PN 25 flanges. The largest pumps have DN 400, PN 40 discharge flanges and a maximum operating pressure of 25 bar.

The pumps are equipped with an unbalanced mechanical shaft seal.

The pumps are of the top-pull-out design, i.e. the power head (motor, motor stool and impeller) can be removed for maintenance or service while the pump housing remains in the pipework.

As radial and axial forces are absorbed by the fixed bearing in the motor drive-end, the pump requires no bearing.

TP Series 400 pumps are equipped with high-efficiency motors.

## Materials

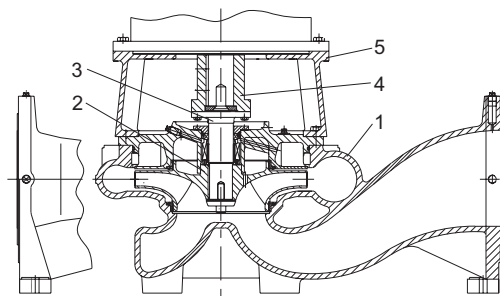

TM02 8492 0204

Fig. 8 Sectional drawing of TP Series 400

## Material specification

### TP Series 400, PN 10

Pos.	Component	Material	EN/DIN
1	Pump housing	Cast iron EN-GJL-250	EN-JL1040
2	Impeller	Ductile cast iron EN-GJS-400	EN-JL1030
		Bronze	2.1096.01
3	Pump shaft	Stainless steel	1.4436
4	Coupling	Cast iron EN-GJL-250	EN-JL1040
5	Motor stool	Cast iron EN-GJL-250	EN-JL1040
	Secondary seals	EPDM rubber	
	Rotating seal face	Metal-impregnated carbon Silicon carbide	
	Stationary seat	Silicon carbide	

### TP Series 400, PN 25

Pos.	Component	Material	EN/DIN
1	Pump housing	Ductile cast iron EN-GJS-400-18 (A-LT)	EN-JS1020
2	Impeller	Ductile cast iron EN-GJS-400	EN-JS1030
		Bronze	2.1096.01
3	Pump shaft	Stainless steel	1.4436
4	Coupling	Cast iron EN-GJL-250	EN-JL1040
5	Motor stool	Cast iron EN-GJL-250	EN-JL1040
	Secondary seals	EPDM rubber	
	Rotating seal face	Resin-impregnated carbon	
	Stationary seat	Tungsten carbide	

## Mechanical shaft seal

For 10 bar versions, the following three types of unbalanced mechanical shaft seal are available as standard:

- **BAQE**  
The BAQE shaft seal is a Grundfos rubber bellows seal with carbon/silicon carbide seal faces and secondary seals of EPDM.
- **GQQE**  
The GQQE shaft seal is a Grundfos rubber bellows seal with reduced silicon carbide/silicon carbide seal faces and secondary seals of EPDM.
- **BQQE**  
The BQQE shaft seal is a Grundfos rubber bellows seal with silicon carbide/silicon carbide seal faces and secondary seals of EPDM.

For 25 bar versions, the following mechanical shaft seal is available as standard:

- **DBUE**  
The DBUE shaft seal is a Grundfos balanced O-ring seal with carbon/tungsten carbide seal faces and secondary seals of EPDM.

Information on a selection of common pumped liquids with recommended shaft seals is shown on page 19.

Special shaft seals are available for partly conditioned water or other liquids containing abrasive or crystallising particles. See page 19.

## Connections

TP Series 400 pumps are the only TP pumps with suction and discharge ports of different diameters. The suction port is one dimension larger than the discharge port in order to obtain a low inlet velocity. This reduces risk of cavitation and noise.

From DN 100 to DN 300 TP Series 400 pumps have flanges according to ISO 7005-2 or EN 1092-2.

## Features and benefits

TP Series 400 pumps have the following features and benefits:

### Optimised hydraulics for high efficiency

- Reduced power consumption.

### High-efficiency motors

- TP pumps are fitted with high-efficiency motors. High-efficiency motors offer reduced energy consumption. 2-pole and 4-pole TP pumps from 1.1 to 90 kW have EFF1 motors.

### Top-pull-out design

- Easy dismantling in case of service.

### In-line design

- Contrary to end-suction pumps, in-line pumps allow a straight pipework and thus often reduced installation costs.

### Motor-pump shaft with flange coupling

- Stable and quiet operation.
- Easy dismantling in case of service.

### Supported flange connection

- Pump housing flanges have integrated feet in order to stabilise the pump.

### Surface treatment

TP Series 400 pumps are given the following surface treatment:

Pump type	Electrocoating	Spray painting
TP Series 400 (from DN 100 to DN 300)	x	x
TP Series 400 (DN 400)		2x

Electrocoating includes:

1. Alkaline cleaning
2. Pretreatment with zinc phosphate coating
3. Cathodic electrocoating (epoxy)
4. Curing of paint film at 200-250 °C.

For low-temperature applications at a high humidity, Grundfos offers TP pumps with extra surface treatment to avoid corrosion. These pumps are available on request.



TM03 0347 4904

**Fig. 9** TPE and TPED Series 1000

## Technical data

Flow rate:	Up to 340 m <sup>3</sup> /h
Head:	Up to 90 m
Liquid temperature:	-25 to +140 °C
Max. operating pressure:	16 bar
Motor sizes (single-phase):	0.37 to 1.1 kW
Motor sizes (three-phase):	0.55 to 22 kW

## Construction

TPE, TPED Series 1000 pumps are based on TP, TPD Series 100, 200 and 300 pumps.

The main difference between the TP and the TPE Series 1000 pump range is the motor. The motor of TPE Series 1000 pumps has a built-in frequency converter for continuous adjustment of the pressure to the flow rate.

TPE Series 1000 pumps are suitable for applications where the pressure, temperature, flow rate or another parameter is to be controlled on the basis of signals from a sensor at some point in the system.

**Note:** TPE Series 1000 pumps are **not** fitted with a sensor from factory.

For further information on construction and materials of TPE Series 1000 pumps, see pages 21 to 24.

## Applications

TPE Series 1000 pumps have integrated speed control for automatic adaptation of performance to current conditions.

This ensures that the energy consumption is kept at a minimum.

TPE Series 1000 pumps can operate in any duty point within the range between 25 % and 100 % speed.

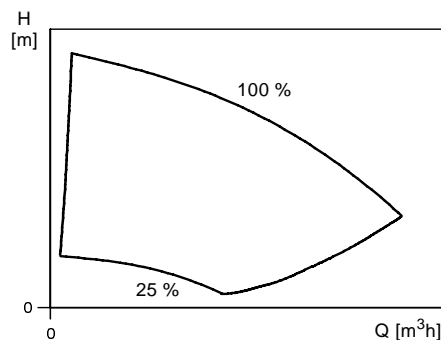

TM01 4916 1099

**Fig. 10** Duty range of TPE Series 1000 pumps

The 100 % curve corresponds to the curve of a pump with a mains-operated motor.

Depending on the application, TPE Series 1000 pumps offer energy-savings, increased comfort or improved processing.

The pumps can be fitted with sensor types meeting the requirements mentioned in the data booklet titled 'Grundfos E-pumps'.

The charts below show possible control modes of TPE Series 1000 pumps in different applications.

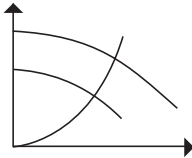
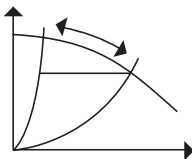
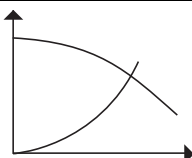
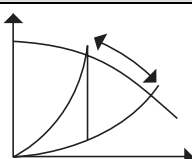
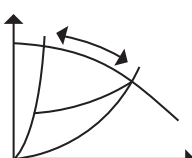
Control mode	Application
<b>Constant curve</b>	
	Single-pipe heating systems. Systems with three-way valves. Heating and cooling surfaces. Chiller pumps.
<b>Constant differential pressure</b>	
	Systems with two-way valves. (Sensor is needed.)
<b>Temperature control</b>	
	Single-pipe heating systems. Systems with three-way valves. Cooling towers. Chiller pumps. Domestic hot water recirculation systems. (Sensor is needed.)
<b>Constant flow rate</b>	
	Heating and cooling surfaces. Cooling towers. Flow filters. (Sensor is needed.)
<b>Proportional differential pressure (measured)</b>	
	System with two-way valves. (The differential pressure sensor is located in the system.)

## Operating modes of twin-head pumps

The following operating modes are available for twin-head pumps:

### Alternating operation

The two pumps run alternately for 24 operating hours. In case of fault in the operating pump, the other pump will start.

### Standby operation

One pump is in constant operation. Every 24 operating hours the standby pump will start and run for a short period to prevent it from seizing up. In case of fault in the operating pump, the standby pump will start.

The operating mode is selected by means of a selector switch in each terminal box.

In case of sensor fault, the operating pump will switch to maximum operation.

## Control options

Communication with TPE, TPED Series 1000 pumps is possible via

- a central building management system
- a remote control (Grundfos R100) or
- a control panel.

The purpose of controlling a TPE, TPED Series 1000 pump is to monitor and control the pressure, temperature, flow rate and liquid level of the system.

For further information on control options of TPE pumps, see page 31.



TM03 0348 4904

Fig. 11 TPE Series 2000

## Technical data

Flow rate:	Up to 340 m <sup>3</sup> /h
Head:	Up to 90 m
Liquid temperature:	-25 to +140 °C
Max. operating pressure:	16 bar
Motor sizes (single-phase):	0.37 to 1.1 kW
Motor sizes (three-phase):	0.55 to 22 kW

## Construction

TPE, TPED Series 2000 pumps are based on TP, TPD Series 200 and 300 pumps.

The main differences between the TP and the TPE Series 2000 pumps are the motor and the factory-fitted differential pressure sensor.

The motor of TPE Series 2000 pumps has built-in frequency converter for continuous adjustment of the pressure to the flow rate.

The TPE Series 2000 range is a preset solution for quick and safe installation.

For further information on construction and materials of TPE Series 2000 pumps, see pages 21 to 24.

## Applications

TPE Series 2000 pumps have integrated speed control for automatic adaptation of performance to current conditions.

This ensures that the energy consumption is kept at a minimum.

TPE Series 2000 pumps can operate in any duty point within the range between 25 % and 100 % speed.

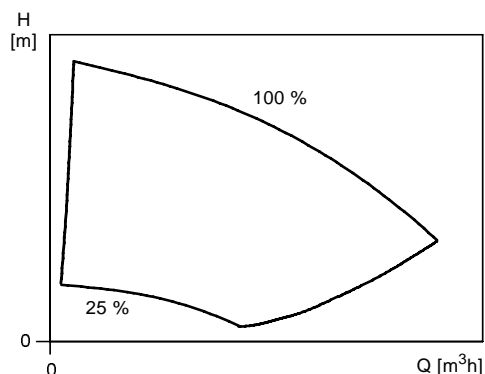

TM01 4916 1099

Fig. 12 Duty range of TPE Series 2000 pumps

The 100 % curve corresponds to the curve of a pump with a mains-operated motor.

Depending on the application, TPE Series 2000 pumps offer energy-savings, increased comfort or improved processing.

TPE Series 2000 pumps are suitable for applications requiring pressure control.

## Proportional pressure

TPE Series 2000 pumps are factory-set to proportional pressure control. We recommend proportional pressure control in systems with relatively large pressure losses, as it is the most economical control mode.

TPE Series 2000 pumps set to proportional pressure control continuously adjust the pump head to the water requirement of the system. The setpoint is factory-set to 50 % of the maximum pump head.

The pumps can be retrofitted with sensor types meeting the requirements mentioned in the data booklet titled 'Grundfos E-pumps'.

The charts below show possible control modes of TPE Series 2000 pumps in different applications.

Control mode	Application
<b>Proportional pressure</b>	Systems with two-way valves. – The head against a closed valve is 50 % of the setpoint.
<b>Constant pressure</b>	Systems with two-way valves.
<b>Constant curve</b>	Single-pipe heating system. Systems with three-way valves. Heating and cooling surfaces. Chiller pumps.

## Operating modes of twin-head pumps

The following operating modes are available for twin-head pumps:

### Alternating operation

The two pumps run alternately for 24 operating hours. In case of fault in the operating pump, the other pump will start.

### Standby operation

One pump is in constant operation. Every 24 operating hours the standby pump will start and run for a short period to prevent it from seizing up. In case of fault in the operating pump, the standby pump will start.

The operating mode is selected by means of a selector switch in each terminal box.

In case of sensor fault, the operating pump will switch to maximum operation.

### Control options

Communication with TPE, TPED Series 2000 pumps is possible via

- a central building management system
- a remote control (Grundfos R100) or
- a control panel.

The purpose of controlling TPE, TPED Series 2000 pumps is to monitor and control the pressure, temperature, flow rate and liquid level of the system.

For further information on control options of TPE pumps, see page 31.

## Communication with TPE, TPED pumps

Communication with TPE, TPED pumps is possible via a central building management system, remote control (Grundfos R100) or control panel.

### Central building management system

The operator can communicate with a TPE, TPED pump at a distance. Communication can take place via a central building management system allowing the operator to monitor and change control modes and setpoint settings.

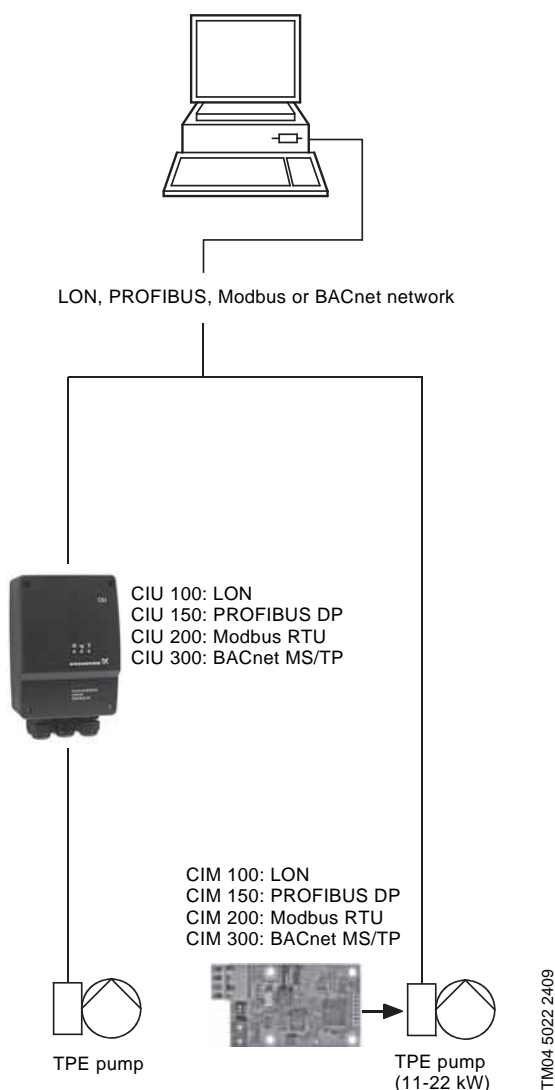

**Fig. 13** Structure of a central building management system

TM04 5022 2409

### Remote control

The R100 remote control produced by Grundfos is available as an accessory.

The operator can communicate with the TPE, TPED pump by pointing the IR-signal transmitter at the control panel of the terminal box.

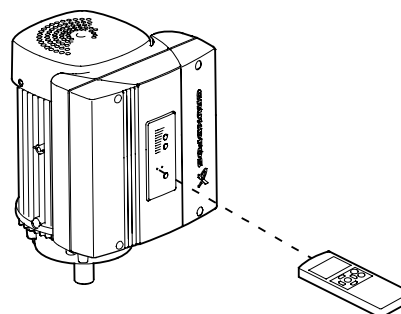

TM03 0141 4104

**Fig. 14** R100 remote control

The operator can monitor and change control modes and settings of the TPE, TPED pump via the R100 display.

### Control panel

The operator can change the setpoint settings manually on the control panel of the TPE, TPED pump terminal box.



TM00 7600 0404

**Fig. 15** Control panel of a TPE pump

## Affinity equations

Normally, TPE, TPED pumps are used in applications characterised by a **variable** flow. Consequently, it is not possible to select a pump that is constantly operating at its optimum efficiency.

In order to achieve optimum operating economy, the duty point should be close to the optimum efficiency ( $\eta$ ) for most operating hours.

Between the min. and max. performance curves, TPE, TPED pumps have an infinite number of performance curves each representing a specific speed. It may therefore not be possible to select a duty point close to the max. curve.

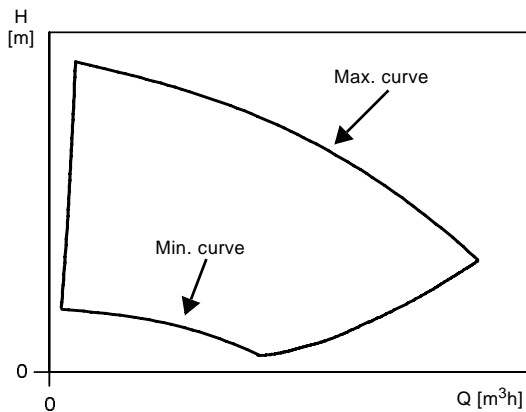

Fig. 16 Min. and max. performance curves

In situations where it is not possible to select a duty point close to the max. curve, use the affinity equations below. The head (H), the flow rate (Q) and the input power (P) are the appropriate variables you need for calculating the motor speed (n).

**Note:** The approximated formulas apply on condition that the system characteristic remains unchanged for  $n_n$  and  $n_x$ , and that it is based on the formula  $H = k \times Q^2$  where k is a constant.

The power equation implies that the pump efficiency is unchanged at the two speeds. In practice this is **not** quite correct.

Finally, it is worth noting that the efficiency of the frequency converter and the motor **must** be taken into account if a precise calculation of the power saving resulting from a reduction of the pump speed is wanted.

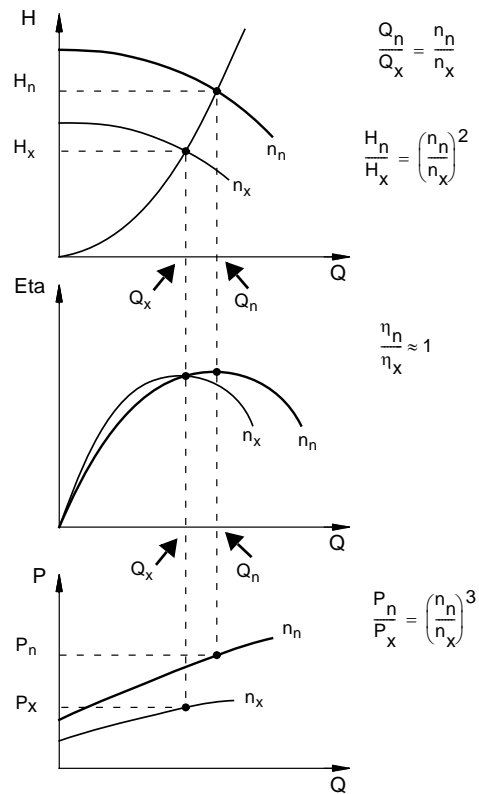

Fig. 17 Affinity equations

### Legend

- $H_n$  Rated head in metres
- $H_x$  Current head in metres
- $Q_n$  Rated flow rate in  $m^3/h$
- $Q_x$  Current flow rate in  $m^3/h$
- $n_n$  Rated motor speed in  $min^{-1}$
- $n_x$  Current motor speed in  $min^{-1}$
- $\eta_n$  Rated efficiency in %
- $\eta_x$  Current efficiency in %

### WinCAPS and WebCAPS

WinCAPS and WebCAPS are selection programs offered by Grundfos.

The two programs make it possible to calculate the specific duty point and energy consumption of a TPE pump.



When you enter the dimensions of the pump, WinCAPS and WebCAPS can calculate the exact duty point and energy consumption. For further information, see page 141.

## Control of TP, TPE pumps connected in parallel

In some applications parallel pump operation is required for one or more of the following reasons:

- One pump cannot achieve the required performance (flow).
- Standby capacity is required to ensure reliability of supply.
- Overall efficiency needs to be improved in case of big variations in the flow demand.

The table below lists the different possibilities of controlling TP, TPE-pumps connected in parallel.

Parallel operation control possibilities	TP, TPE	TPE Series 2000
<b>Built-in alternating/standby function</b>		
	• <sup>1)</sup>	• <sup>1)</sup>
<b>Control MPC</b>		
	•	
<b>Control MPC Series 2000</b>		
		•

• Available

<sup>1)</sup> Applies only to TPED pumps

## Alternation / standby function for TPED pumps

All TPED pumps have built-in alternation/standby function. The pumps are supplied with a special cable for the communication between the two power heads. The function is activated from factory and "alternating" mode is selected as default, see page 28 and page 30.

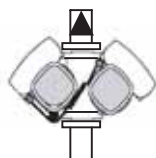

Fig. 18 TPED Series 2000

TM03 0413 5004

## TP, TPE pumps connected to Control MPC

TP, TPE-pumps can be connected directly to Grundfos Control MPC.

Control MPC incorporates among others a CU 351 controller that can control up to 6 pumps.

By means of an external sensor Control MPC can ensure optimum adaptation of the performance to the demand by closed-loop control of:

- proportional differential pressure
- constant differential pressure.
- differential pressure (remote)
- flow
- temperature.

CU 351 incorporates features such as:

### Start-up wizard

Correct installation and commissioning is a prerequisite for attaining optimum performance of the system and trouble-free operation year in and year out.

During commissioning of the system a start-up wizard is shown on the display of the CU 351. The wizard will guide the operator through the various steps via a series of dialogue boxes to ensure that all settings are done in the correct sequence.

### Application optimized software

CU 351 incorporates application optimized software which helps you set up your system to the application in question.

Furthermore, navigating through the menus of the controller is done in a user friendly way - you do not need any training to be able to set and monitor the system.

### Ethernet connection

CU 351 incorporates an Ethernet connection which makes it possible to get full and unlimited access to the setting and monitoring of the system via a remote PC.

### Service port (GENI TTL)

The service port of the CU 351 enables easy access to updating software and data logging in service situations.

### External communication

Control MPC enables communication with other fieldbus protocols. In order to communicate with other fieldbus protocols a GENIbus module and a gateway is needed.

Control MPC can communicate with PROFIBUS, Interbus-S, radio/modem/PLC via G100 gateway and LON bus via G10 LON gateway.

## **TPE Series 2000 pumps connected to Control MPC Series 2000**

TPE Series 2000 pumps are connected directly to Grundfos Control MPC Series 2000 via GENIbus.

Control MPC Series 2000 incorporates among others a CU 351 controller that can control up to 6 pumps.

All pumps must be of the same pump type and size.

Control MPC Series 2000 is used for controlling circulator pumps in heating and air-conditioning applications.

Control MPC Series 2000 ensures optimal adaptation of the performance to the demand by closed-loop control of:

- proportional differential pressure
- constant differential pressure.

By means of an external sensor Control MPC Series 2000 can also ensure optimum adaptation of the performance to the demand by closed-loop control of:

- differential pressure (remote)
- flow
- temperature.

**Note:** For further information about Control MPC and Control MPC Series 2000, see the data booklet titled Control MPC. The data booklet is available in WebCAPS, on [www.grundfos.com](http://www.grundfos.com). For further information on WebCAPS, see page 141.

## TP pumps connected to Grundfos CUE, external frequency converters



GrA 4404

**Fig. 19** Grundfos CUE product range

Grundfos CUE is a complete range of wall-mounted frequency converters for pump control in a wide range of applications.

Grundfos CUE provides a variety of benefits to the end-user.

The benefits include:

- Grundfos E-pump functionality and user interface.
- Application- and pump family-related functions.
- Increased comfort compared to fixed-speed pump solutions.
- Simple installation and commissioning compared to standard frequency converters.
- Enables speed control of pumps up to 250 kW.

## Functions

### Intuitive start-up guide

The start-up guide enables easy installation and commissioning as well as plug-and-pump convenience. Few settings need to be made by the installer as the rest is done automatically or preset from the factory.

### Smart user interface



TM04 3283 4108

**Fig. 20** Grundfos CUE user interface

Grundfos CUE features a unique user-friendly control panel with graphic display and easy-to-use buttons. Panel layout resembles the well-known Grundfos R100 remote control, which is used with Grundfos E-pumps.

### Controlling the value you choose

Grundfos CUE has a built-in PI controller offering closed-loop control of a desired value.

The values include:

- constant differential pressure
- proportional pressure
- constant temperature
- constant differential pressure
- constant flow.

### Wide product range

The CUE product range is quite comprehensive, covering five different voltage ranges, enclosure classes IP20/21 (Nema 1) and IP54/55 (Nema 12), and a wide range of output powers.

The table below provides a general overview.

Input voltage [V]	Output voltage [V]	Motor [kW]
1 x 200-240	3 x 200-240	1.1 - 7.5
3 x 200-240	3 x 200-240	0.75 - 45
3 x 380-500	3 x 380-500	0.55 - 250
3 x 525-600	3 x 525-600	0.75 - 7.5
3 x 525-690	3 x 525-690	11 - 250

## Motors

Motors fitted on TP pumps are totally enclosed, fan-cooled motors with main dimensions to IEC and DIN standards. Electrical tolerances to IEC 34.

### Mounting designation

Pump type	Mounting designation - IEC 34-7
TP Series 100 TP Series 200	IM 3601 (IM B 14) / IM 3611 (IM V 18)
TP Series 300	IM 3001 (IM B 5) / IM 3011 (IM V 1)
TP Series 400	IM 3001 (IM B 5) / IM 3011 (IM V 1)

Relative humidity:	Max. 95 %
Enclosure class:	IP 55
Insulation class:	F, to IEC 85
Ambient temperature:	Max. +55 °C (EFF1 Siemens motors) Max +60 °C (EFF1 MG motors) Max. +40 °C (other motors) Min. -30 °C

If the pump is installed in humid locations, open the lowest drain hole in the motor. This will reduce the motor enclosure class to IP 44.

## Motor range

kW	Mains-operated motors			Electronically speed-controlled motors	
	2-pole	4-pole	6-pole	2-pole	4-pole
0.12	MEZ	MEZ			
0.18					
0.25					
0.37	MG	MG		MGE	MGE
0.55					
0.75					
1.1					
1.5					
2.2					
3.0					
4.0					
5.5					
7.5					
11.0	Siemens	Siemens			
15.0					
18.5					
22.0					
30.0					
37.0					
45.0					
55.0					
75.0					
90.0					
110.0	Siemens	Siemens			
132.0					
160.0					
200.0					
250.0					
315.0					
355.0					
400.0					
500.0					
560.0					
630.0					

MG and MGE are Grundfos motor brands.  
Siemens is a sourced high-quality motor brand.  
The grey-shaded areas indicate non-available motors.

### High-efficiency motors

TP pumps are fitted with high-efficiency motors.

TP, TPD pumps with 2- and 4-pole three-phase motors from 1.1 to 90 kW are equipped with EFF1 motors.

TPE, TPED pumps with three-phase motors, 2-pole from 1.1 to 22 kW and 4-pole from 1.1 to 15 kW, are equipped with motors equivalent to EFF1.

EFF1 is the highest efficiency class defined by CEMEP (European Committee of Manufacturers of Electrical Machines and Power Electronics).

## Motor protection

### MG, Siemens

**Single-phase** motors have integrated, interconnected thermal switches.

**Three-phase** motors must be connected to a motor-protective circuit breaker.

All three-phase mains-operated motors can be connected to an external frequency converter.

If you connect a frequency converter, the motor insulation system will often be overloaded, and the motor will be more noisy than in normal operation. In addition, large motors will be exposed to bearing currents caused by the frequency converter.

If you operate the motor via a frequency converter, consider the following:

- In 2-, 4- and 6-pole motors of 45 kW (frame size 225) and upwards, isolate one of the motor bearings electrically to prevent damaging currents from passing through the motor bearings.
- If you have noise-sensitive applications, you can reduce the motor noise by fitting a dU/dt filter between the motor and the frequency converter. For particularly noise-sensitive applications, we recommend a sinusoidal filter.
- The length of the cable between motor and frequency converter affects the motor load. Therefore, check that the cable length meets the specifications laid down by the frequency converter supplier.
- For supply voltages between 500 and 690 V, fit either a dU/dt filter to reduce voltage peaks, or use a motor with reinforced insulation.
- For supply voltages of 690 V, use a motor with reinforced insulation, and fit a dU/dt filter.

### MGE

MGE motors with built-in frequency converter do not require protection by a motor-protective circuit breaker.

## Electrical data, mains-operated motors

### Electrical data, 2-pole 1 x 220-230/240 V

Motor [kW]	I <sub>1/1</sub> [A]	Cos φ 1/1	η [%]	n [min <sup>-1</sup> ]	I <sub>Start</sub> /I <sub>1/1</sub>
0.12	1.05	1.0	65	2800-2840	3.2-3.6
0.25	2.05/2	0.99	58	2800	-
0.37	2.95/2.7	0.99	60	2770	2.8
0.55	4/3.65	0.99	66	2750	2.8
0.75	5.1/4.75	0.99	69	2780	3.0
1.1	7.4/6.7	0.98-0.99	-	2770	3.9/3.9
1.5	9.9/8.9	0.98-0.99	72-74	2750-2740	3.9/3.9

### Electrical data, 2-pole 3 x 220-240/380-415 V

Motor [kW]	I <sub>1/1</sub> [A]	Cos φ 1/1	η [%]	n [min <sup>-1</sup> ]	I <sub>Start</sub> /I <sub>1/1</sub>
0.12	0.59/0.34	0.8-0.72	71	2800-2850	4.2-4.6
0.18	0.9/0.52	0.79-0.71	67	2800-2850	4.5
0.25	1.18/0.68	0.81-0.72	73	2800-2850	4.0-4.4
0.37	1.74/1	0.8-0.7	77.5-77.5	2850-2880	-
0.55	2.5/1.44	0.8-0.7	79-79	2830-2850	-
0.75	3.3/1.9	0.81-0.71	80-80	2840-2870	-
1.1	4.5/2.6	0.81-0.75	81-81	2820-2850	5.8-6.3
1.5	5.45/3.15	0.87-0.82	85.5	2890-2910	8.5-9.3
2.2	7.70/4.45	0.89-0.87	87.5	2890-2910	8.5-9.5
3.0	10.4/5.95	0.88-0.85	88-88	2910-2930	-
4.0	13.8/8	0.88-0.84	89	2910-2930	11.2-12.3
5.5	19.4/11.2	0.88-0.84	90	2910-2930	10.7-11.7
7.5	25.5-23.4/ 14.8-13.6	0.89-0.88	89.5-90.5	2920-2930	7.8-9.1
11.0	36.5-34.0/ 21.2-19.6	0.90-0.88	90.7-91.7	2930-2940	6.6-7.8
15.0	49.0-45.0/ 28.5-26.0	0.91-0.90	91.2-92.3	2920-2940	6.6-7.8
18.5	60.5-55.5/ 35.0-32.0	0.91-0.90	91.6-92.6	2920-2940	7.1-8.5
22.0	71.5-66.5/ 41.5-38.5	0.91-0.89	91.9-92.8	2920-2940	7.5-8.9
30.0	90.1/52	0.89	93.5	2950	7.0

### Electrical data, 2-pole 3 x 380-415/660-690 V

Motor [kW]	I <sub>1/1</sub> [A]	Cos φ 1/1	η [%]	n [min <sup>-1</sup> ]	I <sub>Start</sub> /I <sub>1/1</sub>
2.2	4.45	0.89-0.87	87.5-87.5	2890-2910	-
3.0	5.95	0.88-0.85	88-88	2910-2930	-
4.0	8	0.88-0.84	89-89	2910-2930	-
5.5	11.2	0.88-0.84	90-90	2910-2930	-
7.5	14.8-13.6/ 8.5-8.1	0.89-0.88	89.5-90.5	2920-2930	7.8-9.1
11.0	21.2-19.6/ 12.2-11.6	0.90-0.88	90.7-91.7	2930-2940	6.6-7.8
15.0	28.5-26.0/ 16.2-15.6	0.91-0.90	91.2-92.3	2920-2940	6.6-7.8
18.5	35.0-32.0/ 20.0-19.2	0.91-0.90	91.6-92.6	2920-2940	7.1-8.5

Motor [kW]	I <sub>1/1</sub> [A]	Cos φ 1/1	η [%]	n [min <sup>-1</sup> ]	I <sub>Start</sub> /I <sub>1/1</sub>
22.0	41.5-38.5/ 23.8-22.8	0.91-0.89	91.9-92.8	2930-2940	7.5-8.9
30.0	52/30	0.89	93.5	2950	7.0
37.0	64/37	0.89	94	2950	7.0
45.0	77/44.5	0.89	94.9	2970	7.3
55.0	93/53.7	0.9	95.3	2980	6.8
75.0	128/73.9	0.89	95.2	2980	7.0
90.0	150/86.6	0.9	95.6	2980	7.6
110.0	182/105	0.91	95.8	2980	6.9
132.0	220/127	0.91	96.0	2980	7.1
160.0	260/150	0.92	96.4	2980	7.1

### Electrical data, 4-pole 1 x 220-230/240 V

Motor [kW]	I <sub>1/1</sub> [A]	Cos φ 1/1	η [%]	n [min <sup>-1</sup> ]	I <sub>Start</sub> /I <sub>1/1</sub>
0.12	0.99	0.99	53.1	1434	2.58
0.18	1.62	0.97	54	1350-1370	2.0
0.25	2.14	0.97	57	1350-1370	2.2
0.37	2.85	0.97	62	1350-1370	2.4
0.55	4	0.97	66	1350-1370	2.6
0.75	5.45	0.96	71	1390-1410	3.2
1.1	7	0.96	75	1420-1430	3.9

### Electrical data, 4-pole 3 x 220-240/380-415 V

Motor [kW]	I <sub>1/1</sub> [A]	Cos φ 1/1	η [%]	n [min <sup>-1</sup> ]	I <sub>Start</sub> /I <sub>1/1</sub>
0.12	0.78/0.45	0.67	54	1380	3.2
0.25	1.48/0.85	0.75-0.65	69	1400-1420	4.0-4.4
0.37	1.9/1.1	0.77-0.67	71	1400-1420	4.0-4.4
0.55	2.6/1.5	0.79-0.7	77	1390-1410	4.3-4.7
0.75	3.3/1.9	0.79-0.7	78	1390-1410	4.3-4.7
1.1	4.3/2.5	0.76	83.8	1430	6.1
1.5	5.9/3.4	0.76	85	1430	6.4
2.2	9/5.2	0.71	86.4	1450	6.0
3.0	11.8/6.75	0.81-0.73	87.5	1450-1460	6.7-7.3
4.0	14.7/8.5	0.77	88.3	1450	6.1
5.5	19.6-18.2/ 11.2-10.4	0.86-0.84	89.0-90.0	1440-1450	7.0-8.2
7.5	26.0-24.4/ 15.2-14.0	0.87-0.85	89.5-90.5	1440-1450	6.7-7.9
11.0	37.5-35.5/ 21.6-20.4	0.88-0.84	91.0-92.0	1460-1470	7.1-8.1
15.0	50.5-48.5/ 29.0-28.0	0.87-0.84	92.6-92.0	1460-1470	7.6-8.7
18.5	60/35.5	0.84	92.5	1470	7.0
22.0	70/40.5	0.84	93	1470	7.3
30.0	92/53	0.87	93.5	1470	7.0

**Electrical data, 4-pole**      **3 x 380-415/660-690 V**

Motor [kW]	$I_{1/1}$ [A]	$\cos \varphi_{1/1}$	$\eta$ [%]	$n$ [ $\text{min}^{-1}$ ]	$\frac{I_{\text{Start}}}{I_{1/1}}$
2.2	5.2/3.0	0.71	86.4	1450	6.0
3.0	6.5/3.8	0.77	87.4	1440	6.3
4.0	8.5/4.9	0.77	88.3	1450	6.1
5.5	11.2-10.4/ 6.50-6.25	0.86-0.84	89.0-90.0	1440-1450	7.0-8.2
7.5	15.2-14.0/ 8.70-8.40	0.87-0.85	89.5-90.5	1440-1450	6.7-7.9
11.0	21.6-20.4/ 12.4-12.0	0.88-0.84	91.0-92.0	1460-1470	7.1-8.1
15.0	29.0-28.0/ 16.8-16.4	0.87-0.84	92.6-92.0	1460-1470	7.6-8.7
18.5	34.5/20	0.84	92.5	1470	7.0
22.0	40.5/23.4	0.84	93	1470	7.3
30.0	53.0/30.5	0.87	93.5	1470	7.0
37.0	67.0/38.5	0.85	94	1480	6.8
45.0	81.0/47.0	0.85	94.5	1480	6.9
55.0	96.0/55.5	0.87	95.1	1490	7.5
75.0	130.0/75.0	0.87	95.1	1490	6.8
90.0	158.0/91.0	0.86	95.4	1490	7.5
110.0	190.0/110.0	0.87	95.9	1490	7.1
132.0	225.0/130.0	0.88	96.1	1490	7.3
160.0	275.0/160.0	0.88	96.3	1490	7.4
200.0	340.0/196.0	0.88	96.4	1490	7.6
250.0	425.0/245.0	0.88	-	1488	-
315.0	540.0/312.0	0.88	-	1488	-
355.0	610.0/350.0	0.87	-	1488	-
400.0	690.0/400.0	0.87	-	1488	-
500.0	850.0/490.0	0.88	-	1488	-
560.0	950.0/550.0	0.88	-	1492	-
630.0	1060.0/610.0	0.88	-	1492	-

**Electrical data, 6-pole**      **3 x 220-240/380-415 V**

Motor [kW]	$I_{1/1}$ [A]	$\cos \varphi_{1/1}$	$\eta$ [%]	$n$ [ $\text{min}^{-1}$ ]	$\frac{I_{\text{Start}}}{I_{1/1}}$
1.5	6.30/3.65	0.70	85	950	6.2
2.2	9.35/5.4	0.70	84	955	6.2
3.0	10.5/6.1	0.85	84	955	6.6
4.0	14.8/8.5	0.81	84	950	6.3
5.5	20.8/12.0	0.77	86	960	7.3
7.5	29.5/17.2	0.72	88	965	5.5

**Electrical data, 6-pole**      **3 x 380-415/660-690 V**

Motor [kW]	$I_{1/1}$ [A]	$\cos \varphi_{1/1}$	$\eta$ [%]	$n$ [ $\text{min}^{-1}$ ]	$\frac{I_{\text{Start}}}{I_{1/1}}$
2.2	5.40/3.10	0.70	84	955	6.2
3.0	6.10/3.50	0.84	84	955	6.9
4.0	8.50/4.90	0.81	84	950	6.3
5.5	12.0/6.95	0.77	96	960	7.3
7.5	17.2/9.85	0.72	88	965	5.5

**Electrical data, speed-controlled motors**
**Electrical data, 2-pole**      **1 x 220-240 V, 2900  $\text{min}^{-1}$** 

Motor [kW]	$I_{1/1}$ [A]
0.37	2.7-2.5
0.55	3.9-3.6
0.75	5.1-4.7
1.1	7.1-6.6

**Electrical data, 2-pole**      **3 x 380-480 V, 2900  $\text{min}^{-1}$** 

Motor [kW]	$I_{1/1}$ [A]
0.75	2.0-1.8
1.1	2.6-2.3
1.5	3.3-2.7
2.2	4.6-3.8
3.0	6.2-5.0
4.0	8.1-6.6
5.5	11.0-8.8
7.5	14.8-11.6
11.0	22.5-18.8
15.0	30-26.0
18.5	37-31.0
22.0	43.5-35.0

**Electrical data, 4-pole**      **1 x 220-240 V, 1450  $\text{min}^{-1}$** 

Motor [kW]	$I_{1/1}$ [A]
0.37	2.8-2.6
0.55	4.0-3.6
0.75	5.3-4.85

**Electrical data, 4-pole**      **3 x 380-480 V, 1450  $\text{min}^{-1}$** 

Motor [kW]	$I_{1/1}$ [A]
0.55	1.5-1.6
0.75	1.8-1.9
1.1	2.5-2.2
1.5	3.3-2.9
2.2	4.6-3.8
3.0	6.2-5.0
4.0	8.1-6.6
5.5	11-9.0
7.5	15.0-12.0
11.0	22.0-17.8
15.0	30.0-25.4
18.5	37.0-30.0

## Mechanical installation

TP, TPD, TPE, TPED pumps with motors smaller than 11 kW can be installed in horizontal or vertical pipework.

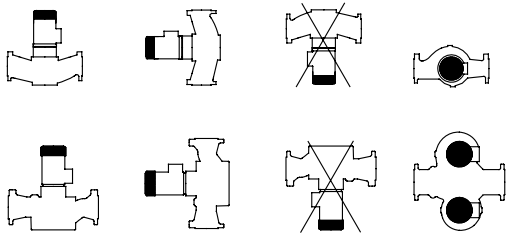

TM00 3734 0897

**Fig. 21** Installation of motor sizes smaller than 11 kW

TP, TPD, TPE, TPED pumps with motors of 11 kW and up may only be installed in horizontal pipes with the motor in vertical position.

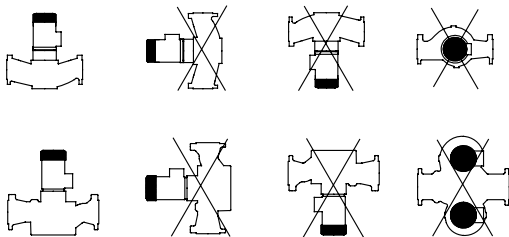

TM00 3735 0897

**Fig. 22** Installation of motor sizes of 11 kW and up

**Note:** The motor must never point downwards.

Install the pumps in such a way that strain from the pipework is not transferred to the pump housing.

Pumps with motors smaller than 11 kW may be suspended direct in the pipes, provided the pipework can support the pump. If not, install the pump on a mounting bracket or base plate.

Pumps with motors of 11 kW and up may only be installed in horizontal pipes with the motor placed in vertical position. Always install the pump on an even and rigid foundation.

When installing a twin-head pump in a horizontal pipe and with horizontal shaft, fit the upper pump housing with an automatic air vent.

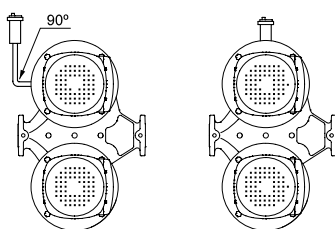

TM03 8127 0507

**Fig. 23** Twin-head pumps with automatic air vent

Twin-head pump housings have two Rp 1/4 tappings (TP Series 200) or four Rp 1/8 tappings (TP Series 300) for mounting of automatic air vents.

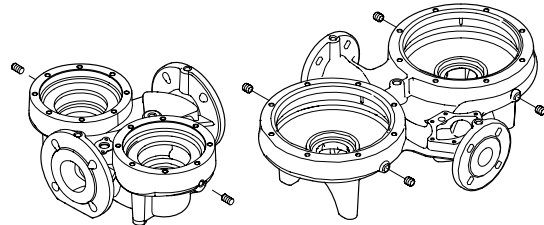

TM02 7533 3703

**Fig. 24** Tappings for mounting of automatic air vents in TP Series 200 and TP Series 300

For further information about identification of TP Series 200 and TP Series 300 models, see page 21 to 23.

If the liquid temperature falls below the ambient temperature, condensation may form in the motor during inactivity. In this case, the drain hole in the motor flange must be open and points downwards. See fig. 25.

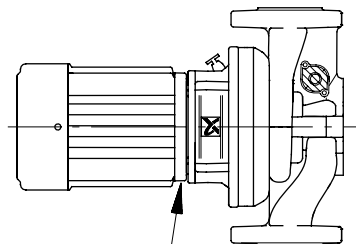

TM00 9831 3202

**Fig. 25** Drain hole

If twin-head pumps are used for pumping liquids with a temperature below 0 °C/32 °F, condensed water may freeze and cause the coupling to get stuck. The problem can be remedied by installing heating elements. Whenever possible, pumps with motors smaller than 11 kW should be installed with horizontal motor shaft. See fig. 23.

## Cooling

To ensure sufficient cooling of motor and electronics, observe the following:

- Place the pump in such a way that sufficient cooling is ensured.
- Make sure that the temperature of the cooling air does not exceed +40 °C.
- Keep the motor cooling fins, holes in fan cover and fan blades clean.
- Make sure the frequency for the motor is at least 6 Hz (12 % of maximum speed). The shaft seal could make noise at speeds below 25 % of maximum speed.

## Condensation cover for TPE pumps

When installing TPE pumps outdoors, provide the motor with a suitable cover to avoid condensation on the electronic components and to protect the pump and motor against the direct effects of the elements.

When mounting the condensation cover on top of the motor, make sure to leave enough space for the air to cool the motor.

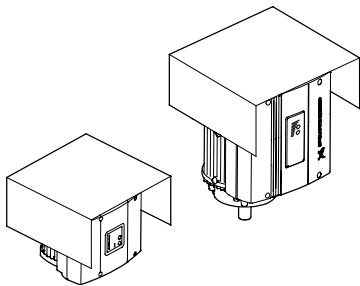

Fig. 26 Speed-controlled motors with condensation cover

TM02 8514 0304

## Elimination of noise and vibrations

In order to achieve optimum operation and minimum noise and vibration, consider vibration dampening of the pump. Generally, always consider this for pumps with motors of 11 kW and up, but for motors of 90 kW and up vibration dampening should be considered as mandatory. Smaller motor sizes, however, may also cause undesirable noise and vibration.

Noise and vibration are generated by the revolutions of the motor and pump and by the flow in pipes and fittings. The effect on the environment is subjective and depends on correct installation and the state of the remaining system.

Elimination of noise and vibrations is best achieved by means of a concrete foundation, vibration dampers and expansion joints.

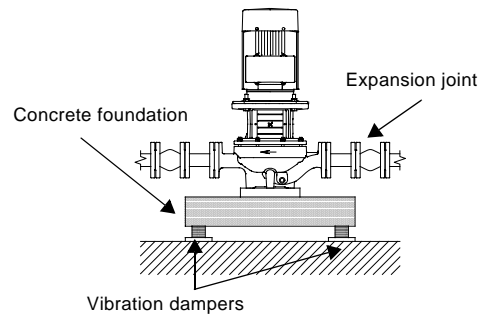

Fig. 27 Foundation of TP pump

## Concrete foundation

Install the pump on a plane and rigid concrete foundation. This is the optimum solution for vibration dampening. As a rule of thumb, the weight of a concrete foundation should be 1.5 times the pump weight.

TM02 4993 2102

## Recommended concrete foundations for TP(D) Series 300 pumps

For TP Series 300 pumps with weights of 150 kg or more, it is recommended to mount the pump on a concrete foundation with the dimensions stated in the table below. The same recommendation applies for TPD Series 300 pumps with weights of 300 kg or more.

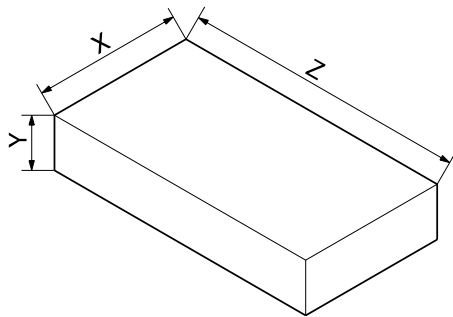

TM03 9190 3507

**Fig. 28** Foundation for TP(D) Series 300 pumps

Concrete foundation dimensions			
Pump mass [kg]	Y (Height) [mm]	Z (Length) [mm]	X (Width) [mm]
150	280	565	565
200	310	620	620
250	330	670	670
300	360	710	710
350	375	750	750
400	390	780	780
450	410	810	810
500	420	840	840
550	440	870	870
600	450	900	900
650	460	920	920
700	470	940	940
750	480	970	970
800	490	990	990
850	500	1010	1010
900	510	1030	1030
950	520	1050	1050
1000	530	1060	1060
1050	540	1080	1080
1100	550	1100	1100
1150	560	1100	1100
1200	560	1130	1130
1250	570	1150	1150
1300	580	1160	1160
1350	590	1180	1180
1400	600	1190	1190
1450	600	1200	1200
1500	610	1220	1220
1550	620	1230	1230
1600	620	1250	1250
1650	630	1250	1250
1700	635	1270	1270

## Vibration dampers

To prevent the transmission of vibrations to buildings, we recommend you to isolate the pump foundation from building parts by means of vibration dampers.

The selection of the right vibration damper requires the following data:

- forces transmitted through the damper
- motor speed considering speed control, if any
- required dampening in % (suggested value is 70 %).

Which is the right damper varies from installation to installation, and a wrong damper may increase the vibration level. Vibration dampers should therefore be sized by the supplier.

If you install the pump on a foundation with vibration dampers, always fit expansion joints on the pump flanges. This is important to prevent the pump from "hanging" in the flanges.

## Expansion joints

Install expansion joints to

- absorb expansions/contractions in the pipework caused by changing liquid temperature.
- reduce mechanical strains in connection with pressure surges in the pipework.
- isolate mechanical structure-borne noise in the pipework (only rubber bellows expansion joints).

**Note:** Do not install expansion joints to compensate for inaccuracies in the pipework such as centre displacement of flanges.

Fit expansion joints at a distance of minimum 1 to 11/2 times the nominal flange diameter away from the pump on the suction as well as on the discharge side. This will prevent the development of turbulence in the expansion joints, resulting in better suction conditions and a minimum pressure loss on the pressure side. At high water velocities (> 5 m/s) we recommend you to install larger expansion joints corresponding to the pipework.

The illustration below shows examples of rubber bellows expansion joints with or without limit rods.

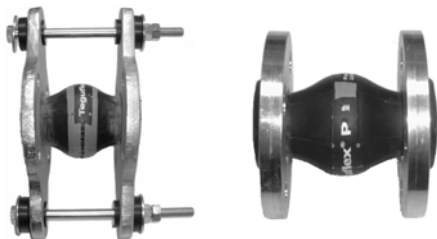

TM02 4979 1902 - TM02 4981 1902

**Fig. 29** Examples of rubber bellows expansion joints

Expansion joints with limit rods can be used to reduce the effects of the expansion/contraction forces on the pipework. We always recommend expansion joints with limit rods for flanges larger than DN 100.

Anchor the pipes in such a way that they do not stress the expansion joints and the pump. Follow the supplier's instructions and pass them on to advisers or pipe installers.

The illustration below shows an example of a metal bellows expansion joint with limit rods.

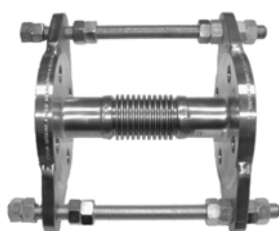

TM02 4980 1902

**Fig. 30** Example of metal expansion joint

Due to the risk of rupture of the rubber bellows, metal bellows expansion joints may be preferred at temperatures above +100 °C combined with high pressure.

## Terminal box positions

### TP single-head pumps

As standard, the terminal boxes of TP and TPE pumps are mounted in position 9 o'clock.

The possible terminal box positions are shown below.

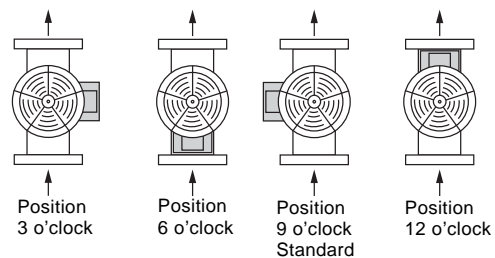

TM03 0565 2005

**Fig. 31** Possible terminal box positions

**Note:** Due to the motor construction the terminal boxes of some TP pumps with motor sizes above 250 kW are mounted in position 10:30.

## TPD twin-head pumps

As standard, the terminal boxes of all TPD and most TPED pumps are mounted in position 12 o'clock, see fig. 31. The TPED pumps with terminal boxes in position 10:30 and 13:30 are listed in the table.

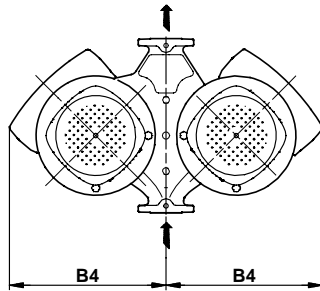

TM02 8630 0604

**Fig. 32** Terminal box positions of TPED pumps

**Note:** The B4 dimension can be seen in the tables of technical data of the individual pump. See the sections on performance curves and technical data.

TPED pumps with terminal boxes in position 10:30 and 13:30			
Single-phase	[kW]	Three-phase	[kW]
TPED 32-60/2	0.37	TPED 32-230/2	0.75
TPED 32-120/2	0.37	TPED 32-200/2	1.1
TPED 40-60/2	0.37	TPED 32-250/2	1.5
TPED 40-120/2	0.37	TPED 32-320/2	2.2
TPED 50-60/2	0.37	TPED 32-380/2	3.0
TPED 32-30/4	0.37	TPED 32-460/2	4.0
TPED 40-30/4	0.37	TPED 32-580/2	5.5
TPED 50-30/4	0.37	TPED 40-190/2	0.75
		TPED 40-230/2	1.1
		TPED 40-270/2	1.5
		TPED 40-240/2	2.2
		TPED 40-300/2	3.0
		TPED 40-360/2	4.0
		TPED 40-470/2	5.5
		TPED 40-580/2	7.5
		TPED 50-120/2	0.75
		TPED 50-160/2	1.1
		TPED 50-180/2	0.75
		TPED 50-190/2	1.5
		TPED 50-240/2	2.2
		TPED 50-290/2	3.0
		TPED 50-360/2	4.0
		TPED 50-430/2	5.5
		TPED 50-570/2	11
		TPED 50-710/2	15
		TPED 50-830/2	18.5
		TPED 50-900/2	22
		TPED 65-120/2	1.1
		TPED 65-180/2	1.5
		TPED 65-190/2	2.2
		TPED 65-230/2	3.0
		TPED 65-260/2	4.0
		TPED 65-340/2	5.5
		TPED 65-410/2	7.5
		TPED 65-460/2	11
		TPED 65-550/2	15
		TPED 65-660/2	18.5
		TPED 65-720/2	22
		TPED 80-120/2	1.5
		TPED 80-210/2	4.0
		TPED 80-240/2	5.5
		TPED 80-330/2	11
		TPED 80-400/2	15
		TPED 80-520/2	18.5
		TPED 80-570/2	22
		TPED 100-120/2	2.2
		TPED 65-60/4	0.55
		TPED 65-90/4	0.75
		TPED 80-60/4	0.75
		TPED 100-30/4	0.55
		TPED 100-60/4	1.1

## Electrical installation

### Electrical connection

Carry out electrical connection and protection in accordance with local regulations.

- The pump must be connected to an external mains switch with a minimum contact gap of 3 mm in all poles.
- Electronically speed-controlled pumps must always be correctly earthed.  
**Note:** The 4.0 - 22 kW motors must be connected to especially reliable/sturdy earth connections to avoid earth leakage currents above 3.5 mA.
- Single-phase motors incorporate thermal protection and require no additional motor protection.
- Three-phase mains-operated motors must be connected to a motor-protective circuit breaker.
- Motors as from 3 kW incorporate thermistors (PTC). The thermistors are designed according to DIN 44082.
- When the pump is switched on via the mains, the pump will start after approx. 5 seconds.

**Note:** Carry out the mains connection of the pump as shown in the diagram inside the terminal box cover.

Do not start the pump until it has been filled with liquid and vented.

### Protection

#### Protection against fault currents

If the pump is connected to an electric installation where an earth leakage circuit breaker (ELCB) is used as additional protection, the earth leakage circuit breaker must be marked with the following symbols.

- Single-phase:



The earth leakage circuit breaker **must** trip out when earth fault currents with DC content (pulsating DC) occur.

- Three-phase:



The earth leakage circuit breaker **must** trip out when earth fault currents with DC content (pulsating DC) and smooth DC earth fault currents occur.

#### Protection against voltage peaks

If you use speed controllers or frequency converters of other makes than Grundfos, you may have the following problems:

- increased motor noise
- detrimental voltage peaks
- additional motor losses.

Pumps with voltage peaks exceeding 650 V (maximum value) must therefore be protected. The voltage increase rate  $dU/dt$  must not exceed  $500 \text{ V}\mu\text{s}$ . Noise and detrimental voltage peaks can be prevented by fitting an LC filter between the speed controller and the motor.

#### Communication cables for TPE, TPED

Use screened cables (min.  $0.5 \text{ mm}^2$ ) for external on/off switch, digital input, sensor and setpoint signals. The screens of the cables should be connected to frame at both ends.

The screen of the cable must have good frame connection which must be as close as possible to the terminals.

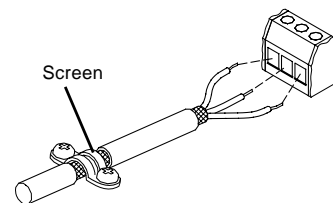

TM02 1325 0901

**Fig. 33** External start/stop cable connection of TPE, TPED

Use a screened 2-core cable for the bus connection. Connect the screen to terminal Y at both ends.

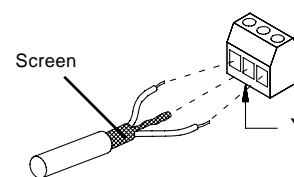

TM02 1343 1001

**Fig. 34** Bus connection of TPE, TPED

## Other connections, TPE, TPED

See the wiring diagrams for instructions on how to connect external potential-free contacts for start/stop and digital function, external setpoint signal and fault signal.

Connect the wires to the following terminal groups:

**Group 1:** Inputs (external start/stop, digital function, setpoint and sensor signals, terminals 1-9 and bus connection, A, Y, B).

All inputs are separated from the mains conducting parts by reinforced insulation.

**Group 2:** Output (signal relay).

The output, terminals C, NO and NC, are galvanically separated from other circuits. Therefore, the supply voltage or protective extra-low voltage can be connected to the output as desired.

**Group 3:** Mains supply.

### Note:

- As a precaution, separate the wires from each other by reinforced insulation in their entire lengths.
- If no external on/off switch is connected, maintain the connection across terminals 2 and 3.

### Wiring diagram, single-phase

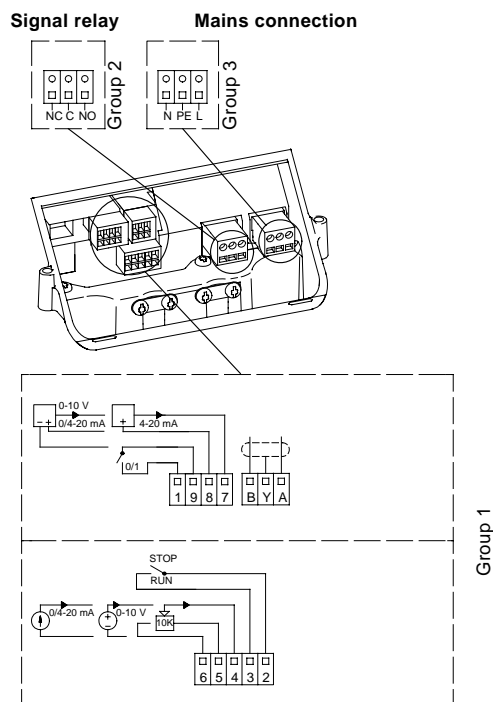

Fig. 35 Wiring diagram, single-phase TPE pumps

TM02 0795 0101

### Wiring diagram, three-phase, 0.75 - 7.5 kW

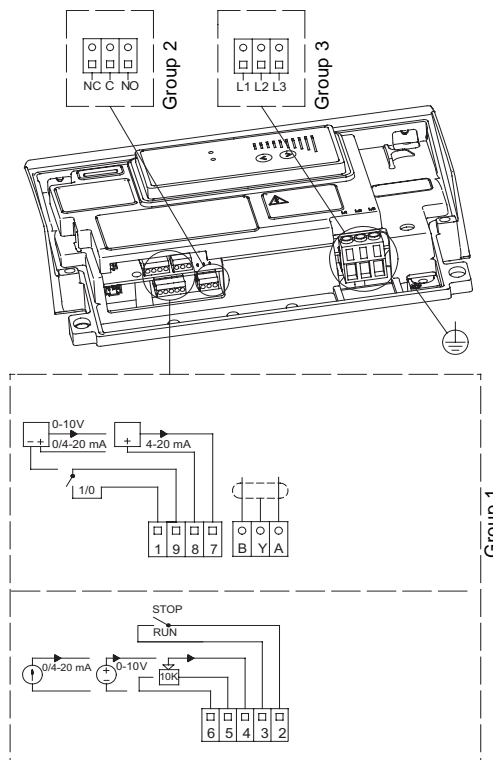

Fig. 36 Wiring diagram, three-phase TPE pumps

TM02 8414 5103

### Wiring diagram, three-phase, 11 - 22 kW

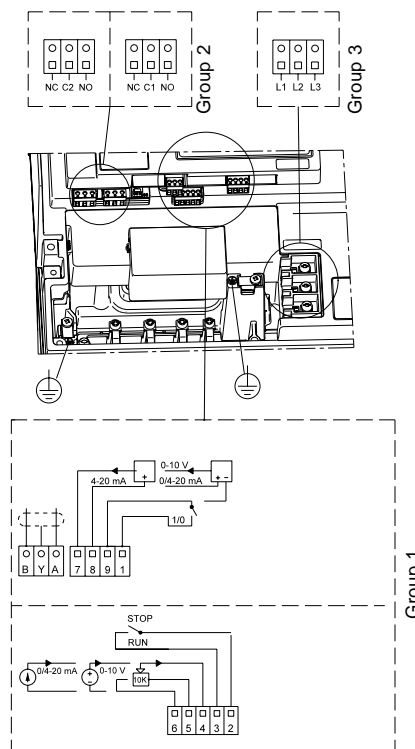
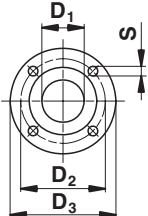

Fig. 37 Wiring diagram, three-phase TPE pumps

TM03 8608 2007

## Flange dimensions

### PN 6 and PN 10 flanges



	EN 1092-2 PN 6 (0.6 MPa)						EN 1092-2 PN 10 (1.0 MPa)									
	Nominal diameter (DN)						Nominal diameter (DN)									
	32	40	50	65	80	100	32	40	50	65	80	100	125	150	200	250
<b>D<sub>1</sub></b>	32	40	50	65	80	100	32	40	50	65	80	100	125	150	200	250
<b>D<sub>2</sub></b>	90	100	110	130	150	170	100	110	125	145	160	180	210	240	295	350
<b>D<sub>3</sub></b>	120	130	140	160	190	210	140	150	165	185	200	220	250	285	340	395
<b>S</b>	4x14	4x14	4x14	4x14	4x19	4x19	4x19	4x19	4x19	4x19	8x19	8x19	8x19	8x23	8x23	12x23

### PN 16 and PN 25 flanges

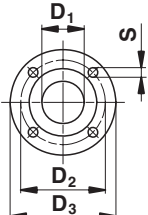

	EN 1092-2 PN 16 (1.6 MPa)						EN 1092-2 PN 25 (2.5 MPa)									
	Nominal diameter (DN)						Nominal diameter (DN)									
	32	40	50	65	80	100	125	150	200	100	125	150	200	250	300	350
<b>D<sub>1</sub></b>	32	40	50	65	80	100	125	150	200	100	125	150	200	250	300	350
<b>D<sub>2</sub></b>	100	110	125	145	160	180	210	240	295	190	220	250	310	370	430	490
<b>D<sub>3</sub></b>	140	150	165	185	200	220	250	285	340	235	270	300	360	425	485	555
<b>S</b>	4x19	4x19	4x19	4x19	8x19	8x19	8x19	8x23	12x23	8x23	8x28	8x28	12x28	12x31	16x31	16x34

### PN 40 flanges

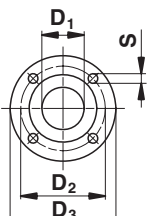

	EN/DIN 2635 PN 40 (4.0 MPa)	
	Nominal diameter (DN)	
	400	500
<b>D<sub>1</sub></b>	400	500
<b>D<sub>2</sub></b>	585	585
<b>D<sub>3</sub></b>	660	660
<b>S</b>	16x42	20x42

## How to read the curve charts

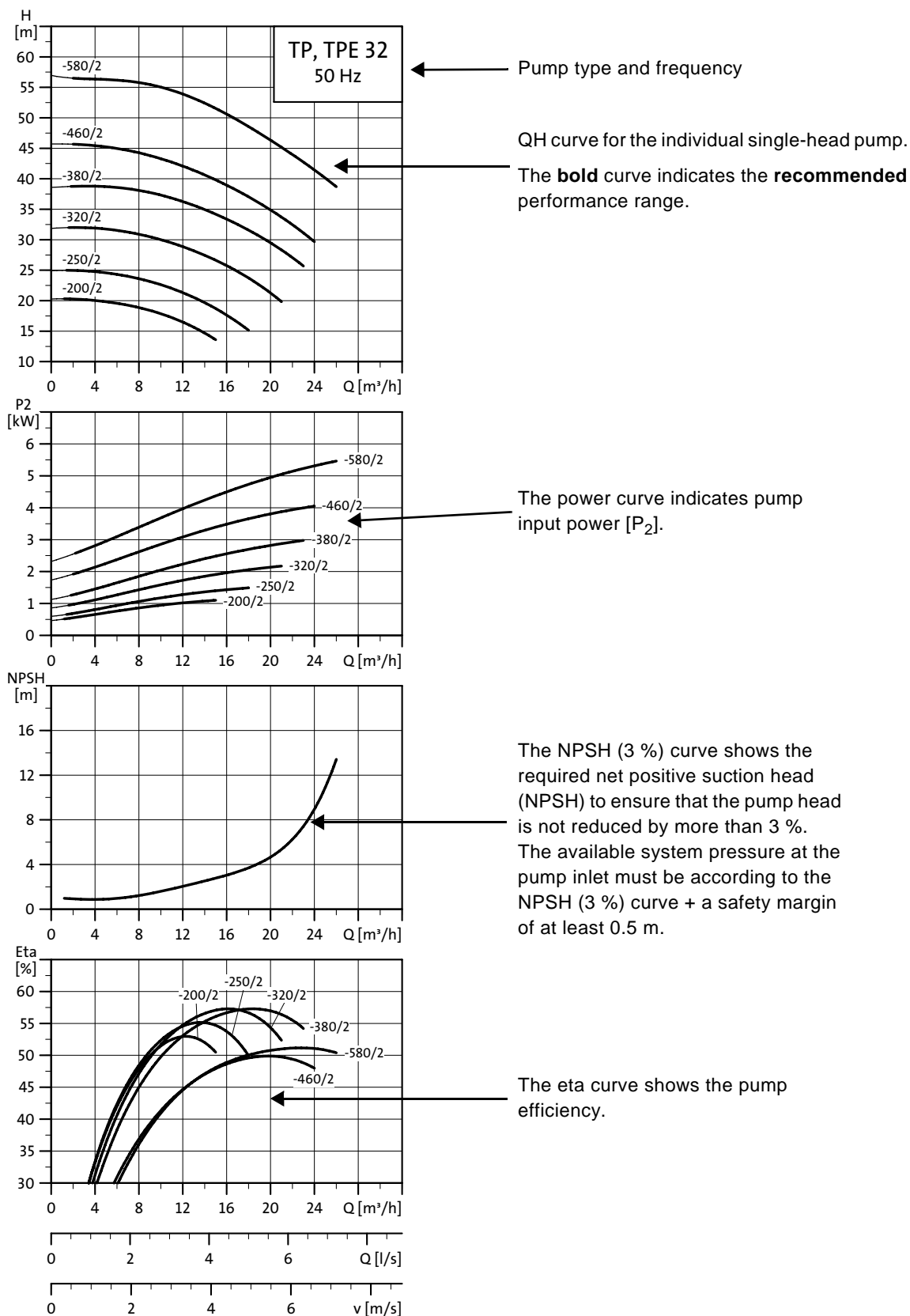

TM02 5017 2102

## Curve conditions

The guidelines below apply to the curves shown on the following pages:

1. Tolerances to ISO 9906, Annex A.
2. The curves apply to the **performance of single-head three-phase pumps**. For other pump versions, please see the exact curves in WinCAPS or WebCAPS. For other pump versions, the performance may differ for the following reasons:
  - The valve in twin-head pumps may cause losses.
  - Single-phase motors run at lower speed.**Note:** Grundfos does not recommend continuous parallel operation of twin-head pumps due to the increased flow in the pump. A too high flow results in noisy operation, increased wear of the impeller due to cavitation, etc.
3. QH curves of the individual single-head pumps are shown with expected speed of a three-phase mains-operated motor. For further information, see the tables of technical data on the following pages. The performance of the single-phase motor is slightly reduced. Please refer to WinCAPS or WebCAPS for the exact single-phase curves.
4. Curves of TPE Series 1000 pumps and TPE Series 2000 pumps are shown as max. curves (100 % curves) only. Please refer to WinCAPS for the exact curves.
5. Measurements have been made with airless water at a temperature of +20 °C.
6. The curves apply to a kinematic viscosity of  $\nu = 1 \text{ mm}^2/\text{s}$  (1 cSt).
7. Due to the risk overheating, the pump must not run constantly below the minimum flow rate indicated by the bold curves.
8. If the pumped liquid density and/or viscosity are higher than those of water, it may be necessary to use a motor with a higher performance.

# Technical data/ performance curves

G 1 1/2  
2-pole, PN 6, 10, 16

TP, TPD, TPE, TPED, 2-pole, PN 6, 10, 16

TP, TPE 25-XX /2 R

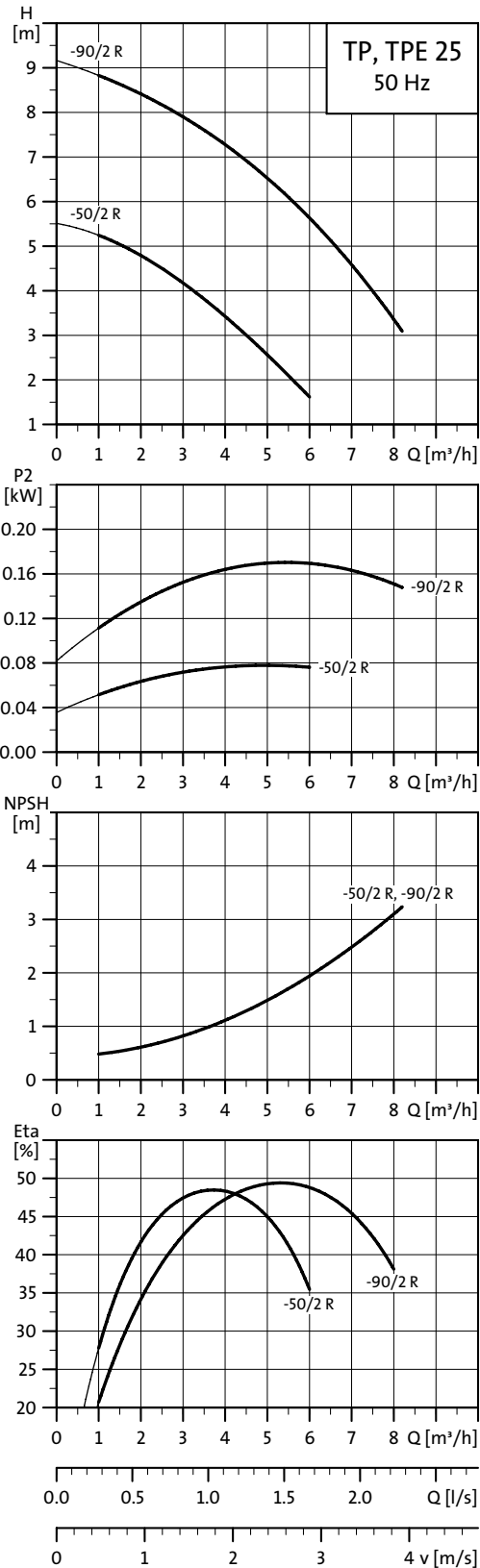

TM02 5014 0504

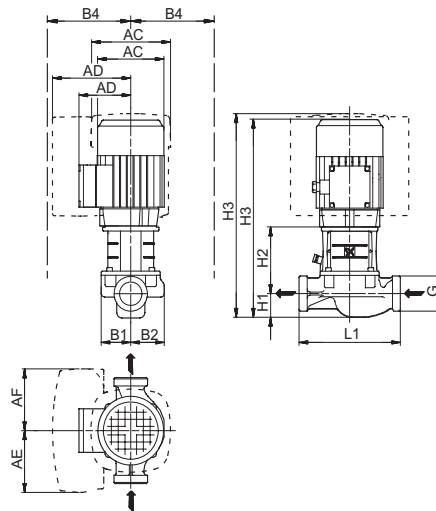

TM02 8348 3307

## Technical data

TP 25		-50/2 R	-90/2 R
TPD		-	-
TPE		●	●
TPED		-	-
Series		100	100
IEC size	1-phase TP	63	71
	3-phase TP	63	63
	1-phase TPE	71	71
	3-phase TPE	-	-
P2	1-/3-phase TP [kW]	0.12/0.12	0.25/0.25
	1-/3-phase TPE [kW]	0.37/-	0.37/-
PN		10	10
T <sub>min</sub> ; T <sub>max</sub>	[°C]	[-25;110]	[-25;110]
G		G 1 ½	G 1 ½
AC	1-/3-phase TP [mm]	118/118	139/118
	1-/3-phase TPE [mm]	141/-	141/-
AD	1-/3-phase TP [mm]	101/101	111/101
	1-/3-phase TPE [mm]	140/-	140/-
AE	1-/3-phase TPE [mm]	105/-	105/-
AF	1-/3-phase TPE [mm]	105/-	105/-
B1	[mm]	54	54
B2	[mm]	52	52
B4	1-/3-phase TP [mm]	101/-	111/-
	1-/3-phase TPE [mm]	140/-	140/-
L1	[mm]	180	180
H1	[mm]	25	25
H2	[mm]	118	118
H3	1-/3-phase TP [mm]	323/323	353/323
	1-/3-phase TPE [mm]	334/-	334/-

## TP, TPE 32-XX/2

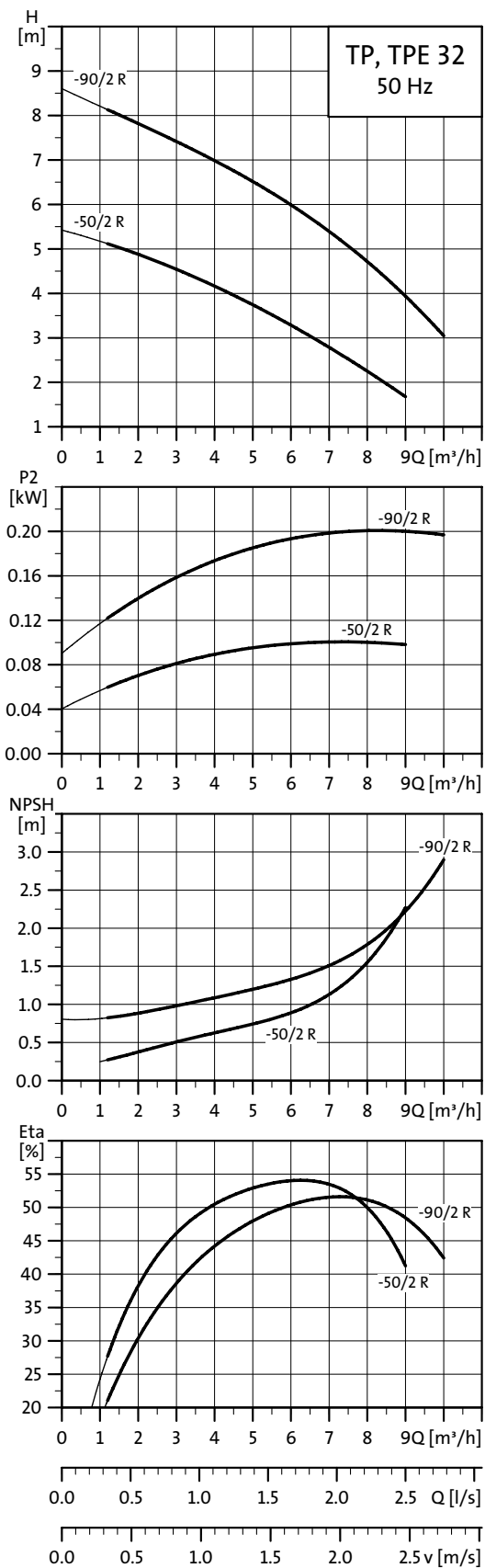

TM02 5015 0504

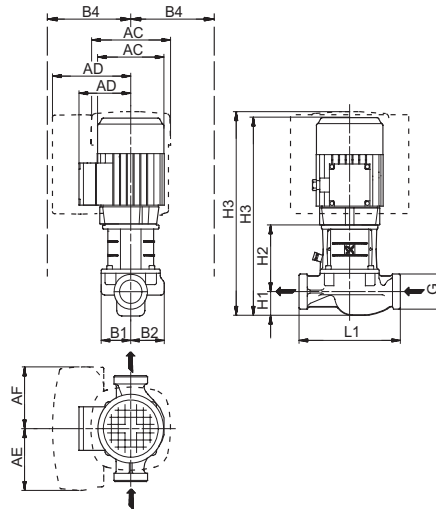

TM02 8348 5004

## Technical data

TP 32		-50/2 R	-90/2 R
TPD		-	-
TPE		●	●
TPED		-	-
Series		100	100
IEC size	1-phase TP	63	71
	3-phase TP	63	63
	1-phase TPE	71	71
	3-phase TPE	-	-
P2	1-/3-phase TP [kW]	0.12/0.12	0.25/0.25
	1-/3-phase TPE [kW]	0.37/-	0.37/-
PN		10	10
T <sub>min</sub> ; T <sub>max</sub>	[°C]	[-25;110]	[-25;110]
G		G 2	G 2
AC	1-/3-phase TP [mm]	118/118	139/118
	1-/3-phase TPE [mm]	141/-	141/-
AD	1-/3-phase TP [mm]	101/101	111/101
	1-/3-phase TPE [mm]	140/-	140/-
AE	1-/3-phase TPE [mm]	105/-	105/-
AF	1-/3-phase TPE [mm]	105/-	105/-
B1	[mm]	51	51
B2	[mm]	60	60
B4	1-/3-phase TP [mm]	101/-	111/-
	1-/3-phase TPE [mm]	140/-	140/-
L1	[mm]	180	180
H1	[mm]	40	40
H2	[mm]	118	118
H3	1-/3-phase TP [mm]	338/338	368/338
	1-/3-phase TPE [mm]	334/-	334/-

## TP, TPD, TPE, TPED 32-XX/2

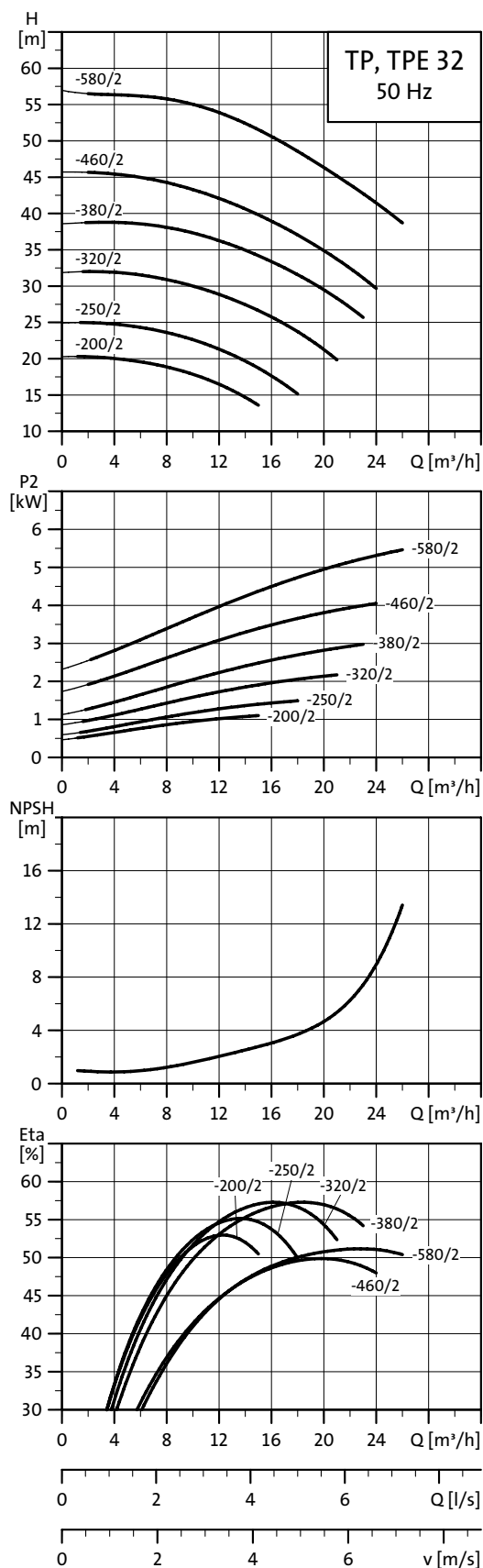
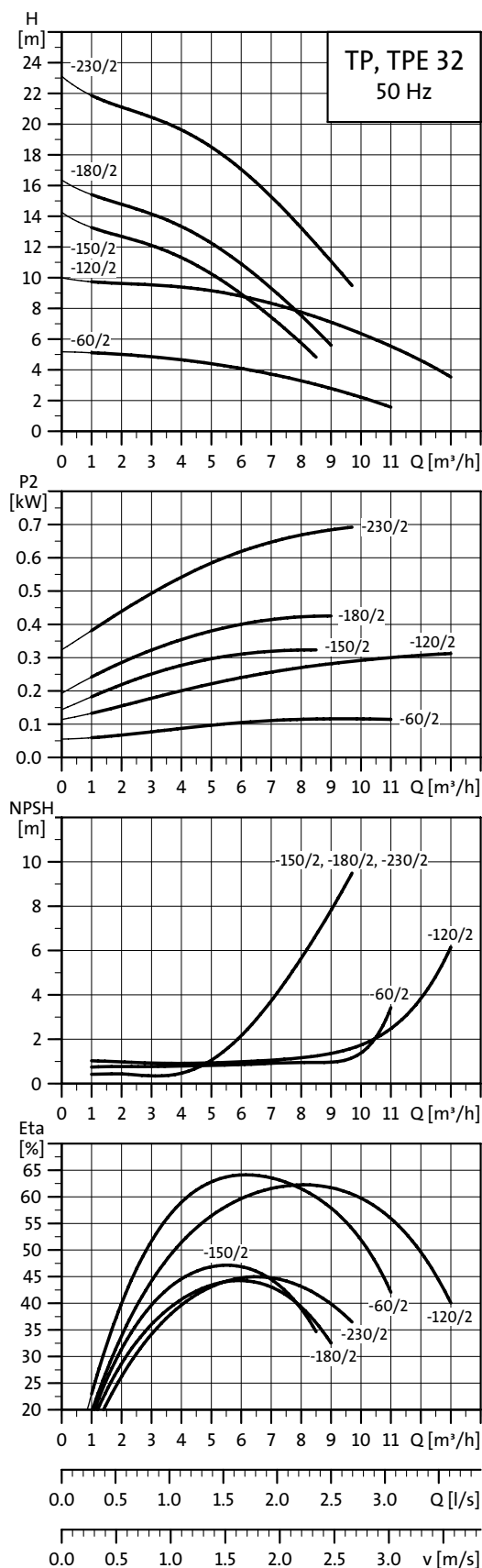

**Note:** All curves apply to single-head pumps. For further information, see page 49.

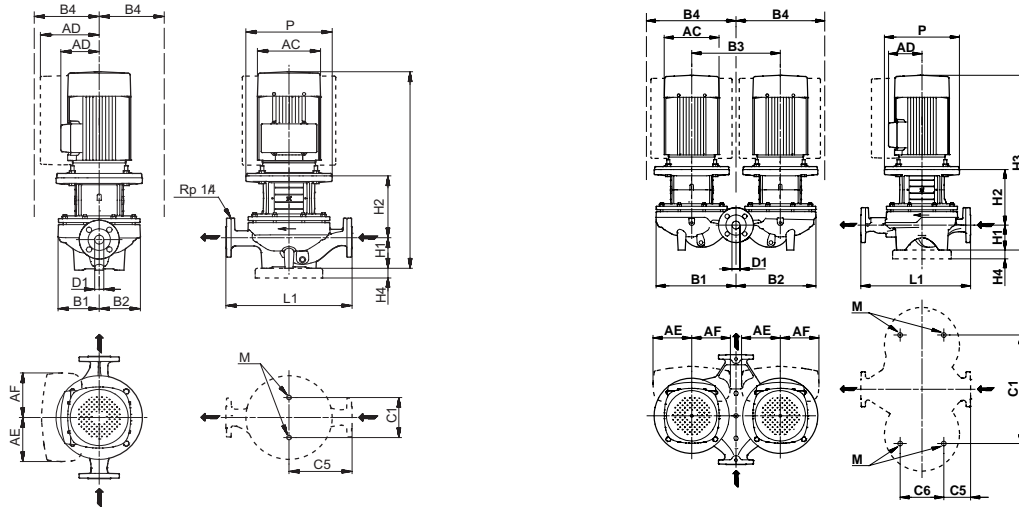

TM02 8632 3307 - TM02 8631 5004

## Technical data

TP 32		-60/2	-120/2	-150/2	-180/2	-230/2	-200/2	-250/2	-320/2	-380/2	-460/2	-580/2
TPD		●	●	●	●	●	●	●	●	●	●	●
TPE		●	●	●	●	●	●	●	●	●	●	●
TPED		●	●	●	●	●	●	●	●	●	●	●
Series		200	200	200	200	200	300	300	300	300	300	300
IEC size	1-phase TP	71	71	71	80	80	-	-	-	-	-	-
	3-phase TP	63	71	71	71	80	80	90	90	100	112	132
	1-phase TPE	71	71	71	71	80	80	-	-	-	-	-
	3-phase TPE	-	-	-	-	90	80	90	90	100	112	132
P2	1-/3-phase TP* [kW]	0.25/0.18	0.25/0.37	0.37/0.37	0.55/0.55	0.75/0.75	-1.1	-1.5	-2.2	-3	-4	-5.5
	1-/3-phase TPE [kW]	0.37/-	0.37/-	0.37/-	0.55/-	0.75/0.75	1.1/1.1	-1.5	-2.2	-3	-4	-5.5
PN		PN 6/10	PN 6/10	PN 6/10	PN 6/10	PN 6/10	PN 16	PN 16	PN 16	PN 16	PN 16	PN 16
T <sub>min</sub> ; T <sub>max</sub>	[°C]	[-25;140]	[-25;140]	[-25;140]	[-25;140]	[-25;140]	[-25;120]	[-25;120]	[-25;120]	[-25;120]	[-25;120]	[-25;120]
D1		32	32	32	32	32	32	32	32	32	32	32
AC	1-/3-phase TP [mm]	139/118	141/141	141/141	141/141	141/141	-141	-178	-178	-198	-220	-220
	1-/3-phase TPE [mm]	141/-	141/-	141/-	141/-	141/178	141/178	-178	-178	-198	-220	-220
AD	1-/3-phase TP [mm]	111/101	133/109	133/109	133/109	133/109	-109	-110	-110	-120	-134	-134
	1-/3-phase TPE [mm]	140/-	140/-	140/-	140/-	140/167	140/167	-167	-167	-177	-188	-188
AE	1-/3-phase TPE [mm]	105/-	105/-	105/-	105/-	105/132	105/105	-132	-132	-132	-145	-145
AF	1-/3-phase TPE [mm]	105/-	105/-	105/-	105/-	105/132	105/105	-132	-132	-132	-145	-145
P	[mm]	-	-	-	-	-	200	200	200	250	250	300
B1**	[mm]	75/180	75/180	102/222	102/222	102/222	125/260	125/260	125/260	125/260	144/321	144/321
B2**	[mm]	75/180	75/180	102/222	102/222	102/222	117/257	117/257	117/257	117/257	144/321	144/321
B3	[mm]	200	200	240	240	240	276	276	276	276	355	355
B4**	TP [mm]	111/180	133/180	133/222	133/222	133/222	125/260	125/260	125/260	125/263	144/321	150/328
	1-phase TPE [mm]	140/264	140/264	140/225	140/225	140/225	140/338	-	-	-	-	-
	3-phase TPE [mm]	-	-	-	-	167/320	140/338	167/338	167/338	177/344	188/403	188/403
C1**	[mm]	80/200	80/200	80/240	80/240	80/240	144/356	144/356	144/356	144/356	144/435	144/435
C5**	[mm]	110/52	110/52	140/82	140/82	140/82	170/45	170/45	170/45	170/45	220/46	220/46
C6	[mm]	103	103	103	103	103	175	175	175	175	175	175
L1	[mm]	220	220	280	280	280	340	340	340	340	440	440
H1	[mm]	68	68	79	79	79	100	100	100	100	100	100
H2	[mm]	140	126	125	125	137	154	154	154	183	184	223
H3	1-/3-phase TP [mm]	419/388	385/385	395/395	447/395	447/447	-485	-535	-575	-618	-656	-714
	1-/3-phase TPE [mm]	407/-	385/-	395/-	395/-	447/497	485/535	-535	-575	-618	-656	-714
H4	[mm]	-	-	-	-	-	-	-	-	-	-	-
M		M12	M12	M12	M12	M12	M16	M16	M16	M16	M16	M16

\* 2- and 4-pole TP and TPD pumps from 1.1 to 90 kW are fitted with **EFF1** motors as standard.

\*\* The dimension before the slash applies to the single-head pump and the dimension after the slash applies to the twin-head pump.

# Performance curves

DN 40  
2-pole, PN 6, 10, 16

## TP, TPE 40-XX/2

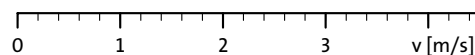
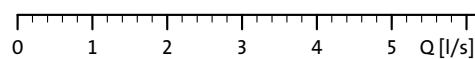
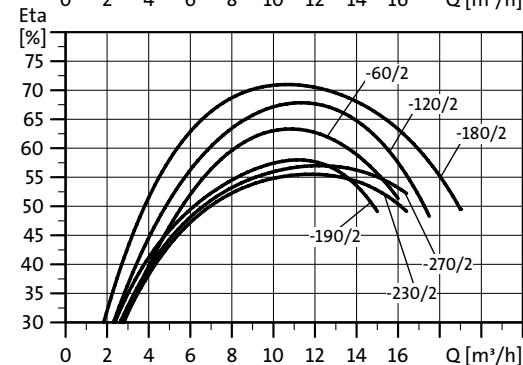
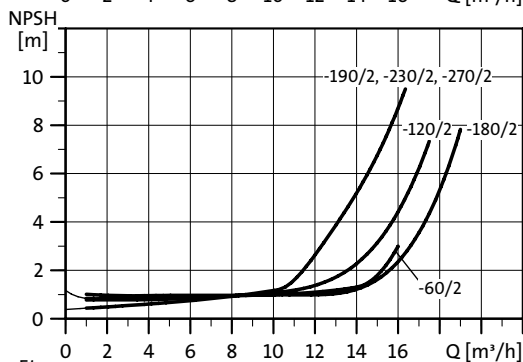
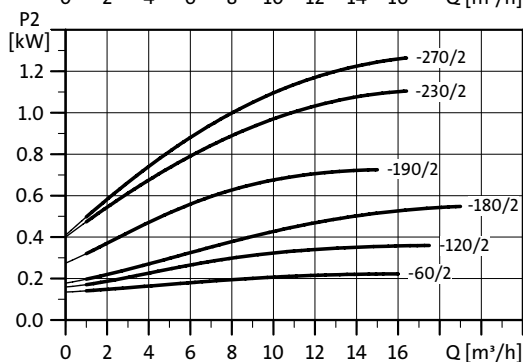
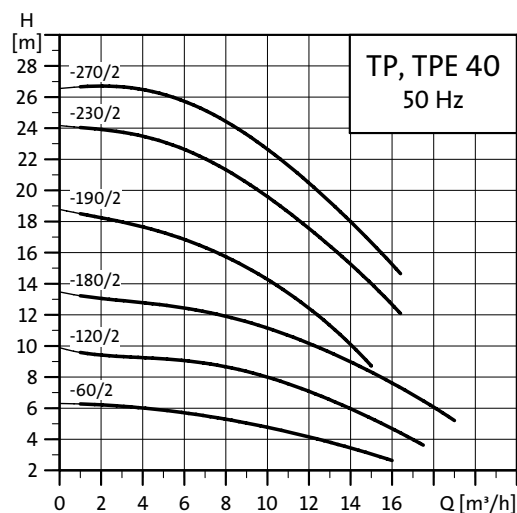
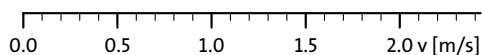
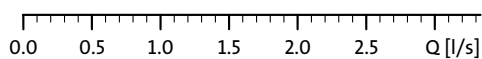
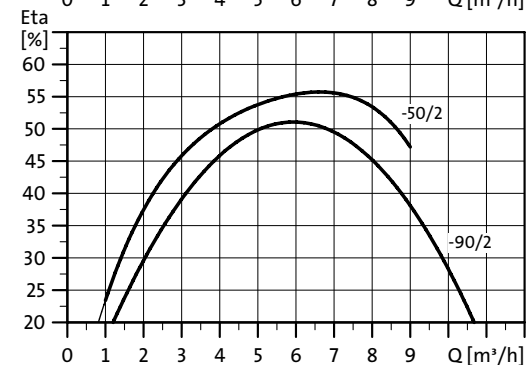
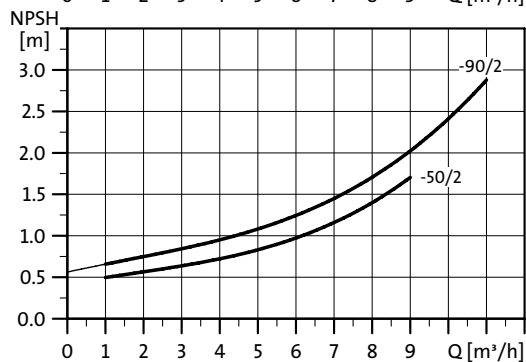
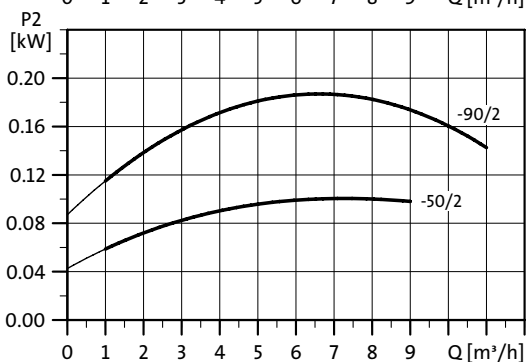
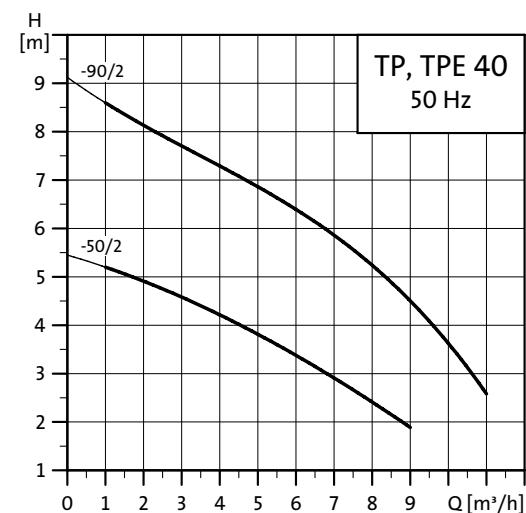

TM02 5018 0504

TM02 5019 0504

Note: All curves apply to single-head pumps. For further information, see page 49.

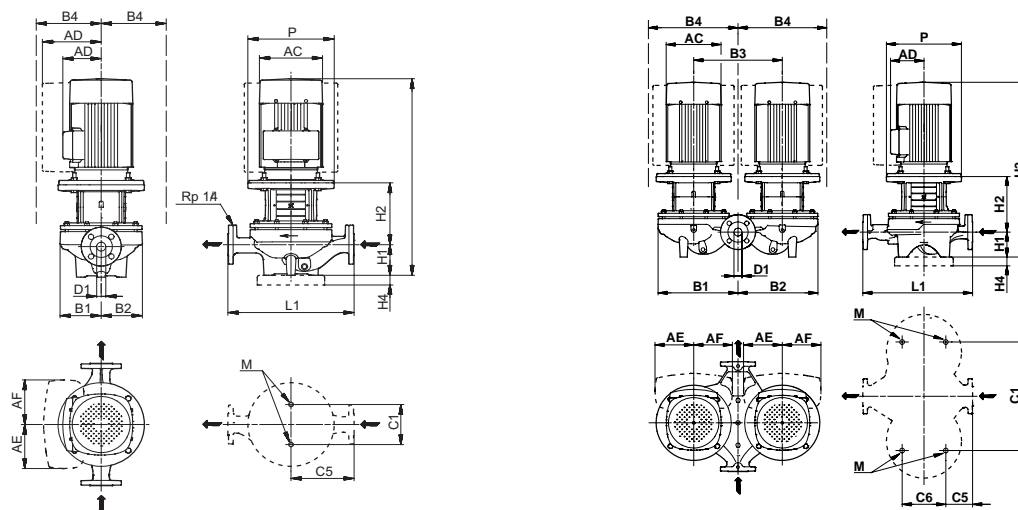

TM02 8632 5004 - TM02 8631 5004

## Technical data

TP 40		-50/2	-60/2	-90/2	-120/2	-180/2	-190/2	-230/2	-270/2
TPD		-	●	-	●	-	●	●	●
TPE		-	●	●	●	●	●	●	●
TPED		-	●	-	●	-	●	●	●
Series		100	200	100	200	200	200	200	200
IEC size	1-phase TP	63	71	71	71	80	80	90	90
	3-phase TP	63	71	63	71	71	80	80	90
	1-phase TPE	71	71	71	71	71	80	80	-
	3-phase TPE	-	-	-	-	-	90	90	90
P2	1-/3-phase TP* [kW]	0.12/0.12	0.25/0.25	0.25/0.25	0.37/0.37	0.55/0.55	0.75/0.75	1.1/1.1	1.5/1.5
	1-/3-phase TPE [kW]	0.37/-	0.37/-	0.37/-	0.37/-	0.55/-	0.75/0.75	1.1/1.1	-/1.5
PN		PN 6/10	PN 6/10	PN 6/10	PN 6/10	PN 6/10	PN 16	PN 16	PN 16
T <sub>min</sub> ; T <sub>max</sub>	[°C]	[-25;110]	[-25;140]	[-25;110]	[-25;140]	[-25;140]	[-25;140]	[-25;140]	[-25;140]
D1	[mm]	40	40	40	40	40	40	40	40
AC	1-/3-phase TP [mm]	118/118	141/141	139/118	141/141	141/141	141/141	178/141	178/178
	1-/3-phase TPE [mm]	141/-	141/-	141/-	141/-	141/-	141/178	141/178	-/178
AD	1-/3-phase TP [mm]	101/101	133/109	111/101	133/109	133/109	133/109	139/109	139/110
	1-/3-phase TPE [mm]	140/-	140/-	141/-	140/-	141/-	140/167	140/167	-/167
AE	1-/3-phase TPE [mm]	105/-	105/-	105/-	105/-	105/-	105/132	105/132	-/132
AF	1-/3-phase TPE [mm]	105/-	105/-	105/-	105/-	105/-	105/132	105/132	-/132
P	[mm]	-	-	-	-	-	-	-	-
B1**	[mm]	75/-	75/180	75/-	75/180	100/-	102/222	102/222	102/222
B2**	[mm]	75/-	75/180	75/-	75/180	100/-	102/222	102/222	102/222
B3	[mm]	-	200	-	200	-	240	240	240
	TP [mm]	101/-	133/180	111/-	133/180	133/-	133/222	139/222	139/222
B4**	1-phase TPE [mm]	140/275	140/264	141/275	140/264	141/225	140/225	140/225	-
	3-phase TPE [mm]	-	-	-	-	-	167/320	167/320	167/320
C1**	[mm]	-/-	80/200	-/-	80/200	80/-	120/240	120/240	120/240
C5**	[mm]	-/-	125/45	-/-	125/45	125/-	160/95	160/95	160/95
C6	[mm]	-	125	-	125	-	125	125	125
L1	[mm]	250	250	250	250	250	320	320	320
H1	[mm]	55	67	55	67	68	68	68	68
H2	[mm]	118	129	118	129	131	141	141	151
H3	1-/3-phase TP [mm]	353/353	387/366	383/353	387/387	442/390	439/439	499/490	539/500
	1-/3-phase TPE [mm]	364/-	395/-	364/-	388/-	390/-	320/490	439/490	-/500
H4	[mm]	-	-	-	-	-	-	-	-
M		-	M12	-	M12	M12	M12	M12	M12

\* 2- and 4-pole TP and TPD pumps from 1.1 to 90 kW are fitted with motors as standard.

\*\* The dimension before the slash applies to the single-head pump, and the dimension after the slash applies to the twin-head pump.

# Performance curves

DN 40  
2-pole, PN 6, 10, 16

TP, TPD, TPE, TPED 40-XX/2

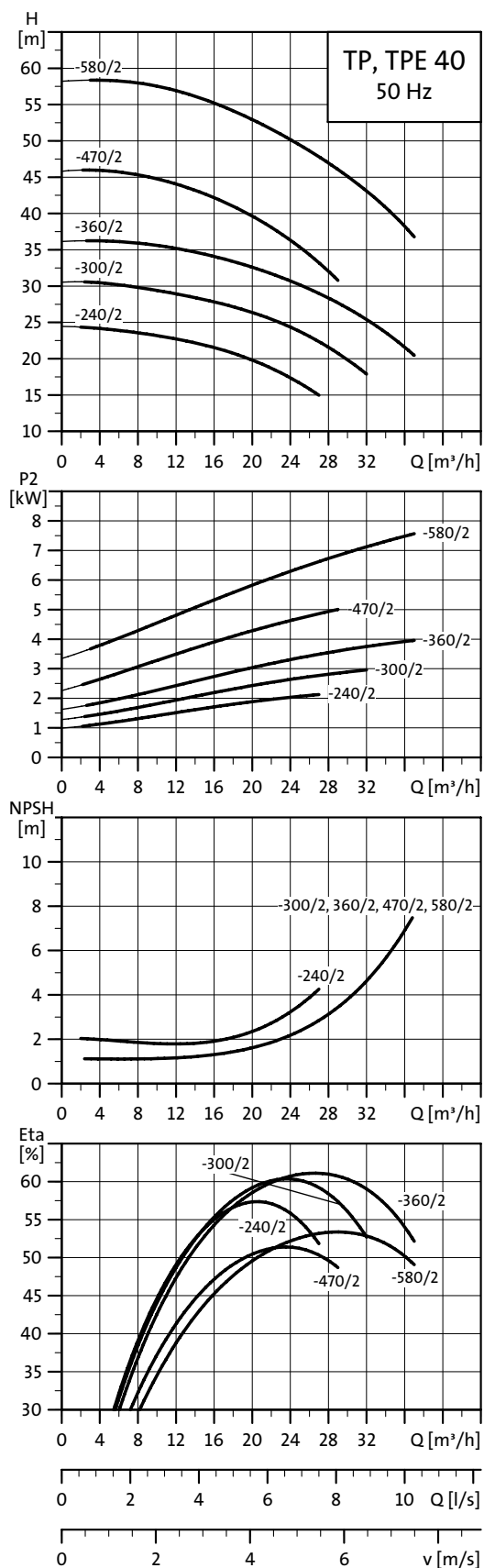

TM02 5020 0504

**Note:** All curves apply to single-head pumps. For further information, see page 49.

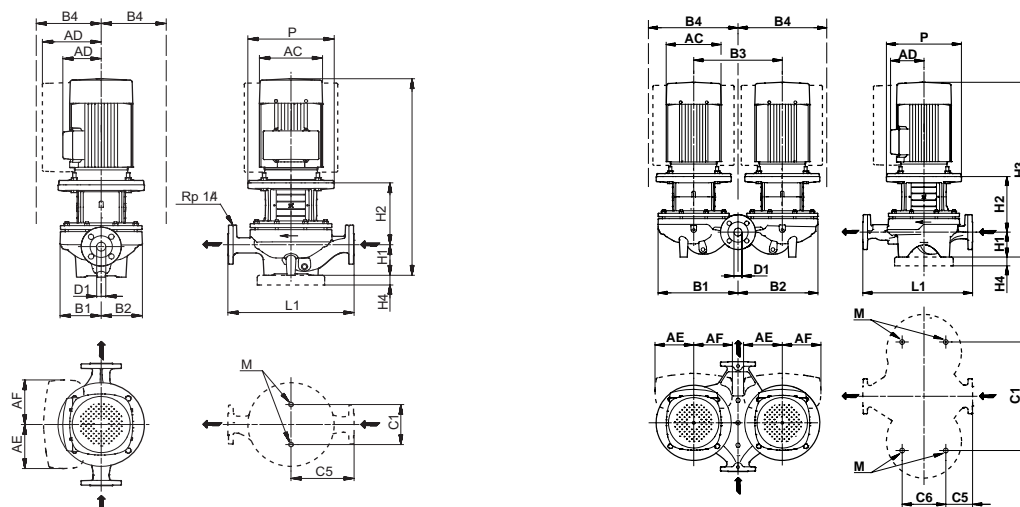

TM02 8632 5004 - TM02 8631 5004

## Technical data

TP 40		-240/2	-300/2	-360/2	-470/2	-580/2
TPD		●	●	●	●	●
TPE		●	●	●	●	●
TPED		●	●	●	●	●
Series		300	300	300	300	300
IEC size	1-phase TP	-	-	-	-	-
	3-phase TP	90	100	112	132	132
	1-phase TPE	-	-	-	-	-
	3-phase TPE	90	100	112	132	132
P2	1-/3-phase TP* [kW]	-/2.2	-/3	-/4	-/5.5	-/7.5
	1-/3-phase TPE [kW]	-/2.2	-/3	-/4	-/5.5	-/7.5
PN		PN 16	PN 16	PN 16	PN 16	PN 16
T <sub>min</sub> ; T <sub>max</sub>	[°C]	[-25;120]	[-25;120]	[-25;120]	[-25;120]	[-25;120]
D1	[mm]	40	40	40	40	40
AC	1-/3-phase TP [mm]	-/178	-/198	-/220	-/220	-/220
	1-/3-phase TPE [mm]	-/178	-/198	-/220	-/220	-/260
AD	1-/3-phase TP [mm]	-/110	-/120	-/134	-/134	-/134
	1-/3-phase TPE [mm]	-/167	-/177	-/188	-/188	-/213
AE	1-/3-phase TPE [mm]	-/132	-/132	-/145	-/145	-/145
AF	1-/3-phase TPE [mm]	-/132	-/132	-/145	-/145	-/145
P	[mm]	200	250	250	300	300
B1**	[mm]	130/273	130/273	130/273	149/325	149/325
B2**	[mm]	117/267	117/267	117/267	144/321	144/321
B3	[mm]	290	290	290	355	355
	TP [mm]	130/273	130/273	134/273	150/328	150/328
B4**	1-phase TPE [mm]	-	-	-	-	-
	3-phase TPE [mm]	167/345	177/351	188/370	188/403	213/414
C1**	[mm]	144/400	144/400	144/400	144/435	144/435
C5**	[mm]	170/45	170/45	170/45	220/108	220/108
C6	[mm]	175	175	175	175	175
L1	[mm]	340	340	340	440	440
H1	[mm]	100	100	100	110	110
H2	[mm]	166	194	194	225	225
H3	1-/3-phase TP [mm]	-/587	-/629	-/666	-/726	-/726
	1-/3-phase TPE [mm]	-/587	-/629	-/666	-/726	-/714
H4	[mm]	-	-	-	-	-
M		M16	M16	M16	M16	M16

\* 2- and 4-pole TP and TPD pumps from 1.1 to 90 kW are fitted with **EFF I** motors as standard.

\*\* The dimension before the slash applies to the single-head pump, and the dimension after the slash applies to the twin-head pump.

## TP, TPD, TPE, TPED 50-XX/2

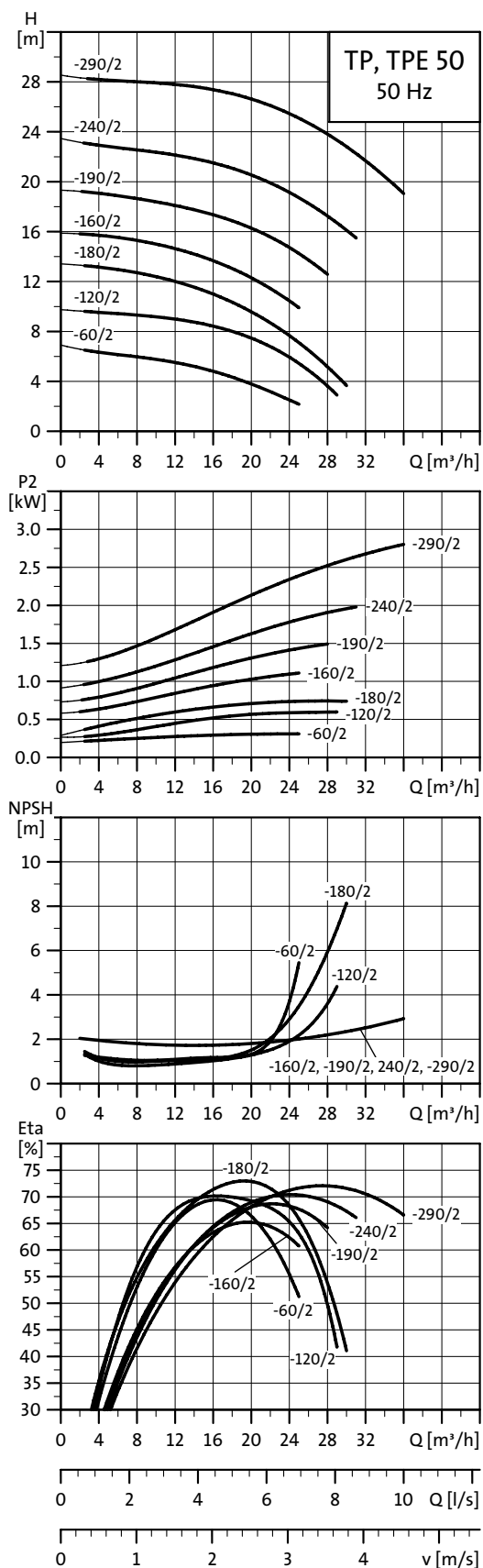

TM02 5021 0504

**Note:** All curves apply to single-head pumps. For further information, see page 49.

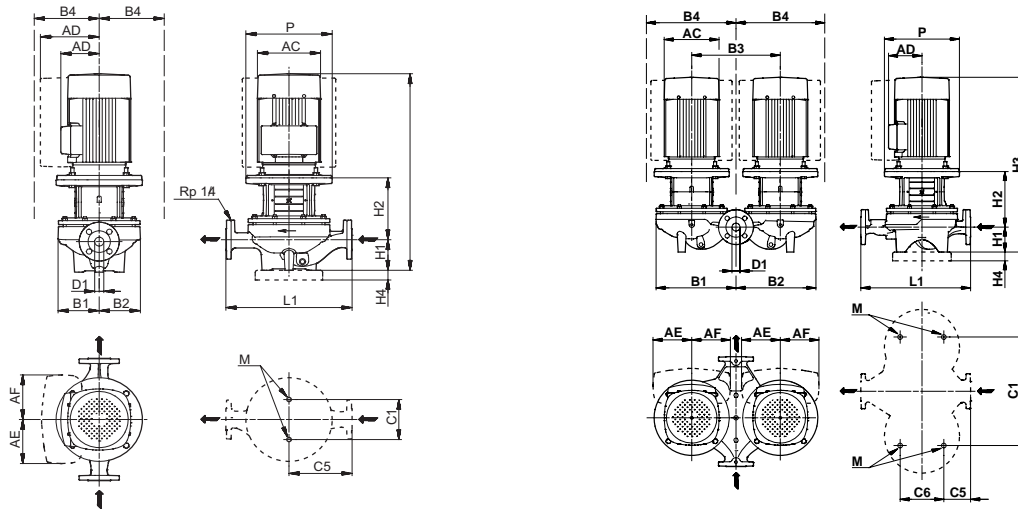

TM02 8632 5004 - TM02 8631 5004

## Technical data

TP 50		-60/2	-120/2	-180/2	-160/2	-190/2	-240/2	-290/2
TPD		●	●	●	●	●	●	●
TPE		●	●	●	●	●	●	●
TPED		●	●	●	●	●	●	●
Series		200	200	200	300	300	300	300
IEC size	1-phase TP	71	80	80	-	-	-	-
	3-phase TP	71	80	80	80	90	90	100
	1-phase TPE	71	80	80	80	-	-	-
	3-phase TPE	-	90	90	80	90	90	100
P2	1-/3-phase TP* [kW]	0.25/0.37	0.55/0.75	0.75/0.75	-/1.1	-/1.5	-/2.2	-/3
	1-/3-phase TPE [kW]	0.37/-	0.75/0.75	0.75/0.75	1.1/1.1	-/1.5	-/2.2	-/3
PN		PN 6/10	PN 6/10	PN 6/10	PN 16	PN 16	PN 16	PN 16
T <sub>min</sub> ; T <sub>max</sub>	[°C]	[-25;140]	[-25;140]	[-25;140]	[-25;120]	[-25;120]	[-25;120]	[-25;120]
D1	[mm]	50	50	50	50	50	50	50
AC	1-/3-phase TP [mm]	141/141	141/141	141/141	-/141	-/178	-/178	-/198
	1-/3-phase TPE [mm]	141/-	141/178	141/178	178/141	-/178	-/178	-/198
AD	1-/3-phase TP [mm]	133/109	133/109	133/109	-/109	-/110	-/110	-/120
	1-/3-phase TPE [mm]	140/-	140/167	140/167	140/167	-/167	-/167	-/177
AE	1-/3-phase TPE [mm]	105/-	105/132	105/132	105/132	-/132	-/132	-/132
AF	1-/3-phase TPE [mm]	105/-	105/132	105/132	105/132	-/132	-/132	-/132
P	[mm]	-	-	-	200	200	200	250
B1**	[mm]	95/180	100/225	100/225	117/252	117/252	117/252	117/252
B2**	[mm]	83/190	100/225	100/225	117/252	117/252	117/252	117/252
B3	[mm]	200	240	240	270	270	270	270
	TP [mm]	133/180	133/225	133/225	117/252	117/252	117/252	125/260
B4**	1-phase TPE [mm]	140/264	140/225	140/225	140/252	-	-	-
	3-phase TPE [mm]	-	167/320	167/320	140/335	167/335	167/335	177/335
C1**	[mm]	120/200	120/240	120/240	144/350	144/350	144/350	144/350
C5**	[mm]	140/60	140/60	140/60	170/60	170/60	170/60	170/60
C6	[mm]	125	126	126	175	175	175	175
L1	[mm]	280	280	280	340	340	340	340
H1	[mm]	75	75	75	115	115	115	115
H2	[mm]	137	135	135	152	152	152	180
H3	1-/3-phase TP [mm]	403/403	441/441	441/441	-/498	-/548	-/588	-/630
	1-/3-phase TPE [mm]	403/-	442/491	441/491	498/548	-/548	-/588	-/630
H4	[mm]	-	-	-	-	-	-	-
M		M12	M12	M12	M16	M16	M16	M16

\* 2- and 4-pole TP and TPD pumps from 1.1 to 90 kW are fitted with motors as standard.

\*\* The dimension before the slash applies to the single-head pump, and the dimension after the slash applies to the twin-head pump.

## TP, TPD, TPE, TPED 50-XX/2

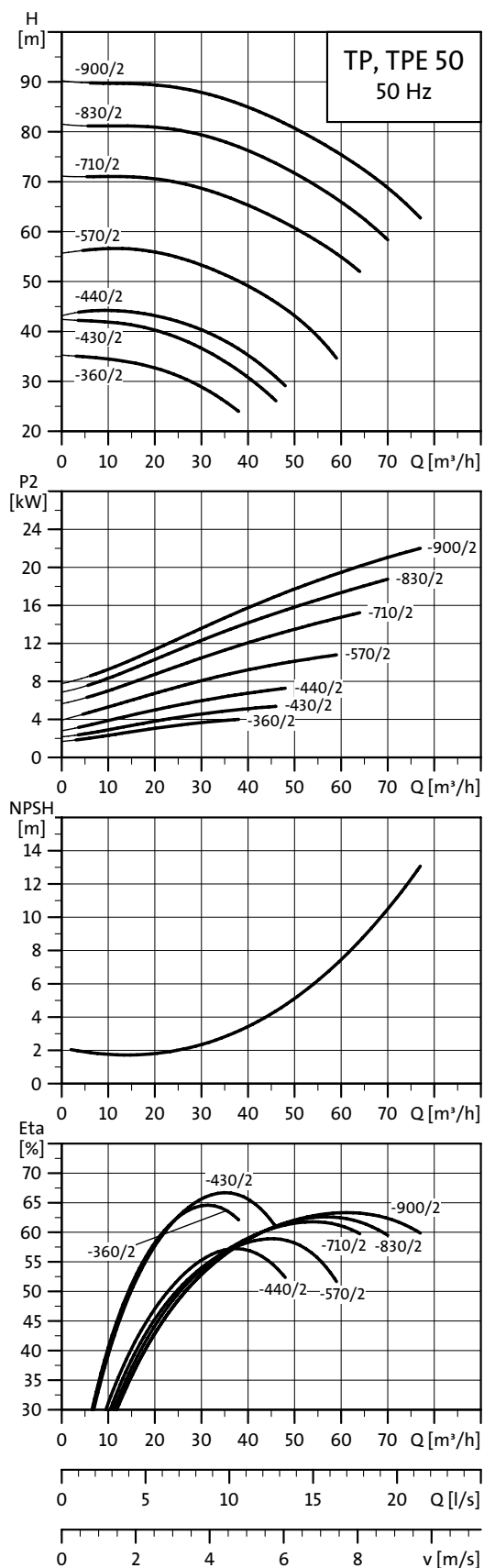

TM02 5022 0504

**Note:** All curves apply to single-head pumps. For further information, see page 49.

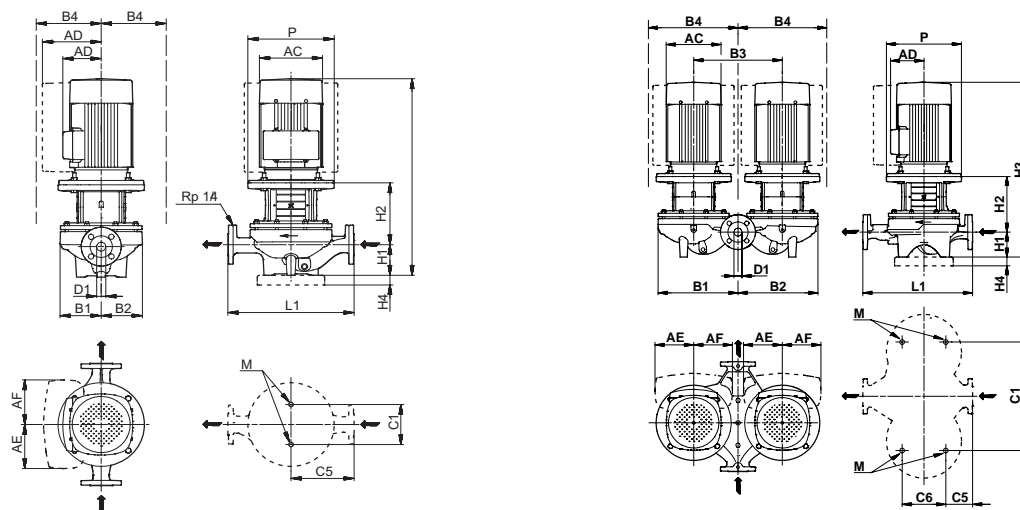

TM02 8632 5004 - TM02 8631 5004

## Technical data

TP 50		-360/2	-430/2	-440/2	-570/2	-710/2	-830/2	-900/2
TPD		●	●	●	●	●	●	●
TPE		●	●	●	●	●	●	●
TPED		●	●	●	●	●	●	●
Series		300	300	300	300	300	300	300
IEC size	1-phase TP	-	-	-	-	-	-	-
	3-phase TP	112	132	132	160	160	160	180
	1-phase TPE	-	-	-	-	-	-	-
	3-phase TPE	112	132	132	160	160	160	180
P2	1-/3-phase TP* [kW]	-/4	-/5.5	-/7.5	-/11	-/15	-/18.5	-/22
	1-/3-phase TPE [kW]	-/4	-/5.5	-/7.5	-/11	-/15	-/18.5	-/22
PN		PN 16	PN 16	PN 16	PN 16	PN 16	PN 16	PN 16
T <sub>min</sub> ; T <sub>max</sub>	[°C]	[-25;120]	[-25;120]	[-25;120]	[-25;120]	[-25;120]	[-25;120]	[-25;120]
D1	[mm]	50	50	50	50	50	50	50
AC	1-/3-phase TP [mm]	-/220	-/220	-/260	-/314	-/314	-/314	-/314
	1-/3-phase TPE [mm]	-/220	-/220	-/260	-/314	-/314	-/314	-/314
AD	1-/3-phase TP [mm]	-/134	-/134	-/159	-/204	-/204	-/204	-/204
	1-/3-phase TPE [mm]	-/188	-/188	-/213	-/308	-/308	-/308	-/308
AE	1-/3-phase TPE [mm]	-/145	-/145	-/145	-/210	-/210	-/210	-/210
AF	1-/3-phase TPE [mm]	-/145	-/145	-/145	-/210	-/210	-/210	-/210
P	[mm]	250	300	300	350	350	350	350
B1**	[mm]	133/290	133/290	180/386	180/386	180/386	180/386	180/386
B2**	[mm]	119/284	119/284	164/379	164/379	164/379	164/379	164/379
B3	[mm]	320	320	420	420	420	420	420
B4**	TP [mm]	134/290	150/310	180/386	204/386	204/386	204/386	204/386
	1-phase TPE [mm]	-	-	-	-	-	-	-
	3-phase TPE [mm]	188/385	188/385	213/386	308/548	308/548	308/548	308/548
C1**	[mm]	144/400	144/400	144/500	144/500	144/500	144/500	144/500
C5**	[mm]	170/52	170/52	220/123	220/123	220/123	220/123	220/123
C6	[mm]	175	175	175	175	175	175	175
L1	[mm]	340	340	440	440	440	440	440
H1	[mm]	115	115	115	115	115	115	115
H2	[mm]	189	228	234	264	264	264	264
H3	1-/3-phase TP [mm]	-/676	-/734	-/728	-/850	-/850	-/894	-/894
	1-/3-phase TPE [mm]	-/676	-/734	-/728	-/850	-/850	-/894	-/920
H4	[mm]	-	-	-	35	35	35	35
M		M16	M16	M16	M16	M16	M16	M16

\* 2- and 4-pole TP and TPD pumps from 1.1 to 90 kW are fitted with **EFF I** motors as standard.

\*\* The dimension before the slash applies to the single-head pump, and the dimension after the slash applies to the twin-head pump.

# Performance curves

DN 65  
2-pole, PN 6, 10, 16

TP, TPD, TPE, TPED 65-XX/2

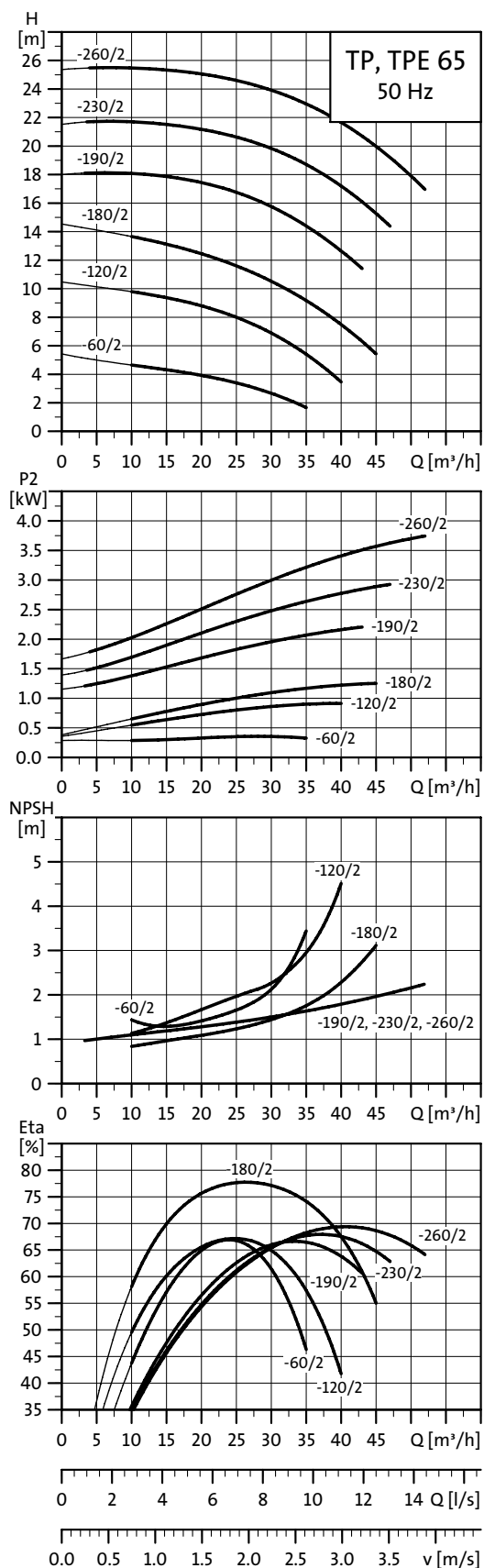

TM02 5023 0504

**Note:** All curves apply to single-head pumps. For further information, see page 49.

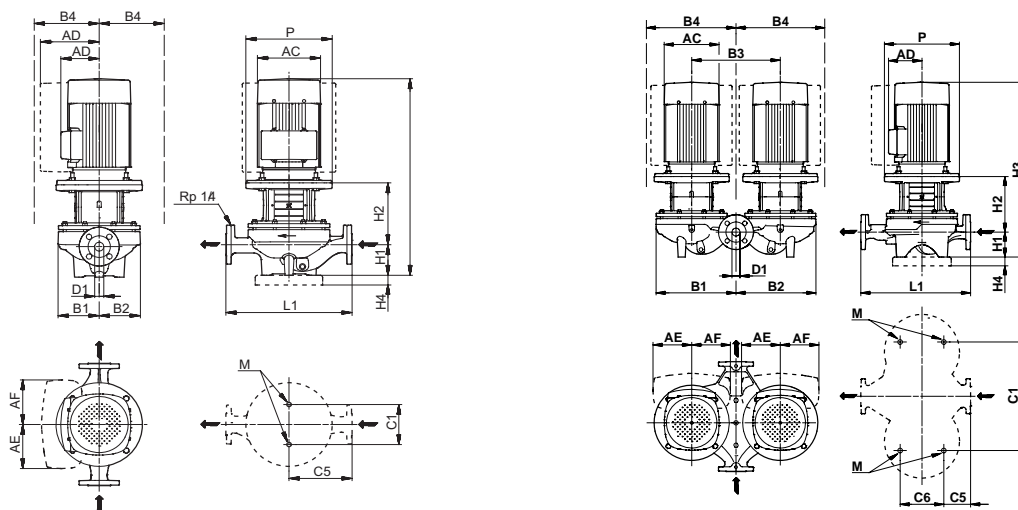

TM02 8632 5004 - TM02 8631 5004

## Technical data

TP 65		-60/2	-120/2	-180/2	-190/2	-230/2	-260/2
TPD		●	●	●	●	●	●
TPE		●	●	●	●	●	●
TPED		●	●	●	●	●	●
Series		200	200	200	300	300	300
IEC size	1-phase TP	80	90	90	-	-	-
	3-phase TP	71	80	90	90	100	112
	1-phase TPE	71	80	-	-	-	-
	3-phase TPE	-	90	90	90	100	112
P2	1-/3-phase TP* [kW]	0.55/0.55	1.1/1.1	1.5/1.5	-/2.2	-/3	-/4
	1-/3-phase TPE [kW]	0.55/-	1.1/1.1	-/1.5	-/2.2	-/3	-/4
PN		PN 6/10	PN 6/10	PN 6/10	PN 16	PN 16	PN 16
T <sub>min</sub> ; T <sub>max</sub>	[°C]	[-25;140]	[-25;140]	[-25;140]	[-25;120]	[-25;120]	[-25;120]
D1		65	65	65	65	65	65
AC	1-/3-phase TP [mm]	141/141	178/141	178/178	-/178	-/198	-/220
	1-/3-phase TPE [mm]	141/-	141/178	-/178	-/178	-/198	-/220
AD	1-/3-phase TP [mm]	133/109	139/109	139/110	-/110	-/120	-/134
	1-/3-phase TPE [mm]	140/-	140/167	-/167	-/167	-/177	-/188
AE	1-/3-phase TPE [mm]	105/-	105/132	-/132	-/132	-/132	-/145
AF	1-/3-phase TPE [mm]	105/-	105/132	-/132	-/132	-/132	-/145
P	[mm]	-	-	-	200	250	250
B1**	[mm]	93/195	100/225	100/225	142/298	142/298	142/298
B2**	[mm]	93/210	100/225	100/225	124/290	124/290	124/290
B3	[mm]	240	240	240	320	320	320
	TP [mm]	133/195	139/225	139/225	142/298	142/298	142/298
B4**	1-phase TPE [mm]	140/225	140/225	-	-	-	-
	3-phase TPE [mm]	-	167/320	167/320	167/360	177/366	188/385
C1**	[mm]	120/240	120/240	120/240	144/400	144/400	144/400
C5**	[mm]	170/63	170/63	170/63	180/65	180/65	180/65
C6	[mm]	153	153	153	175	175	175
L1	[mm]	340	340	340	360	360	360
H1	[mm]	82	82	82	105	105	105
H2	[mm]	145	144	154	172	201	201
H3	1-/3-phase TP [mm]	468/418	517/512	557/507	-/598	-/641	-/678
	1-/3-phase TPE [mm]	418/-	462/512	-/517	-/598	-/641	-/678
H4	[mm]	-	-	-	-	-	-
M		M12	M12	M12	M16	M16	M16

\* 2- and 4-pole TP and TPD pumps from 1.1 to 90 kW are fitted with **EFF I** motors as standard.

\*\* The dimension before the slash applies to the single-head pump, and the dimension after the slash applies to the twin-head pump.

## TP, TPD, TPE, TPED 65-XX/2

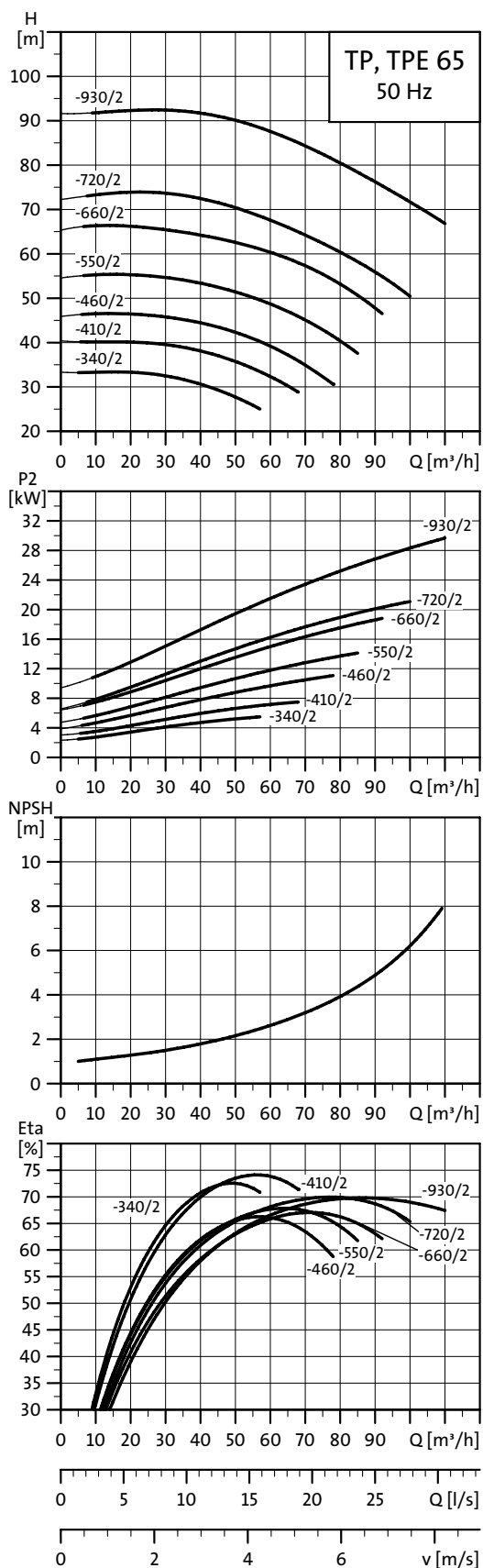

TM02 5024 0504

**Note:** All curves apply to single-head pumps. For further information, see page 49.

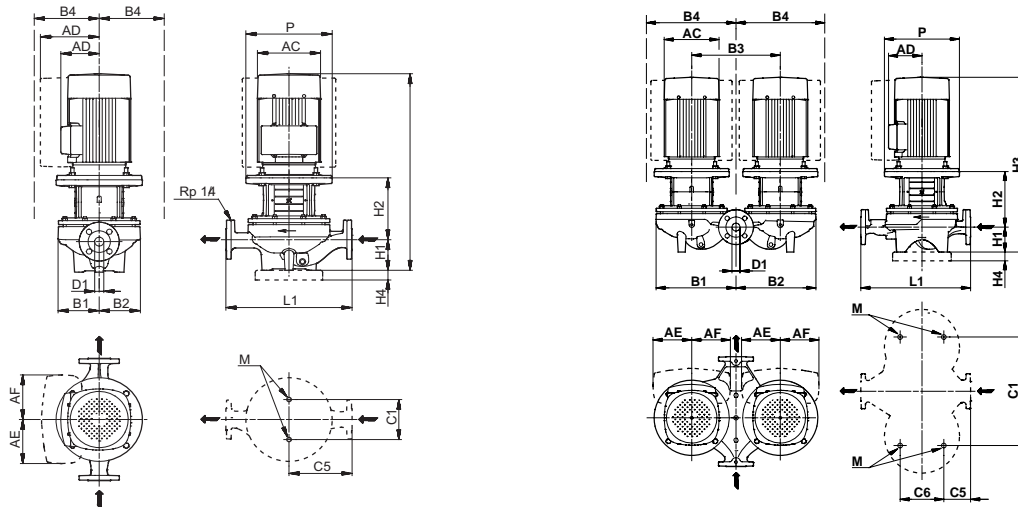

TM02 8632 5004 - TM02 8631 5004

## Technical data

TP 65		-340/2	-410/2	-460/2	-550/2	-660/2	-720/2	-930/2
TPD		●	●	●	●	●	●	●
TPE		●	●	●	●	●	●	-
TPED		●	●	●	●	●	●	-
Series		300	300	300	300	300	300	300
IEC size	1-phase TP	-	-	-	-	-	-	-
	3-phase TP	132	132	160	160	160	180	200
	1-phase TPE	-	-	-	-	-	-	-
	3-phase TPE	132	132	160	160	160	180	-
P2	1-/3-phase TP* [kW]	-/5.5	-/7.5	-/11	-/15	-/18.5	-/22	-/30
	1-/3-phase TPE [kW]	-/5.5	-/7.5	-/11	-/15	-/18.5	-/22	-/-
PN		PN 16	PN 16	PN 16	PN 16	PN 16	PN 16	PN 16
T <sub>min</sub> ; T <sub>max</sub>	[°C]	[-25;120]	[-25;120]	[-25;120]	[-25;120]	[-25;120]	[-25;120]	[-25;120]
D1		65	65	65	65	65	65	65
AC	1-/3-phase TP [mm]	-/220	-/220	-/260	-/320	-/320	-/363	-/402
	1-/3-phase TPE [mm]	-/220	-/260	-/314	-/314	-/314	-/314	-/-
AD	1-/3-phase TP [mm]	-/134	-/134	-/172	-/197	-/197	-/258	-/305
	1-/3-phase TPE [mm]	-/188	-/213	-/308	-/308	-/308	-/308	-/-
AE	1-/3-phase TPE [mm]	-/145	-/145	-/210	-/210	-/210	-/210	-
AF	1-/3-phase TPE [mm]	-/145	-/145	-/210	-/210	-/210	-/210	-
P	[mm]	300	300	350	350	350	350	400
B1**	[mm]	142/298	142/298	178/349	178/349	178/349	178/349	178/349
B2**	[mm]	124/290	124/290	164/383	164/383	164/383	164/383	164/383
B3	[mm]	320	320	440	440	440	440	440
	TP [mm]	150/310	150/310	178/395	197/395	197/395	258/402	305/421
B4**	1-phase TPE [mm]	-	-	-	-	-	-	-
	3-phase TPE [mm]	188/385	213/396	308/558	308/558	308/558	308/558	-
C1**	[mm]	144/400	144/400	144/520	144/520	144/520	144/520	144/520
C5**	[mm]	180/65	180/65	238/111	238/111	238/111	238/111	238/111
C6	[mm]	175	175	175	175	175	175	175
L1	[mm]	360	360	475	475	475	475	475
H1	[mm]	105	105	125	125	125	125	125
H2	[mm]	239	239	263	263	263	263	263
H3	1-/3-phase TP [mm]	-/735	-/735	-/852	-/866	-/906	-/990	-/1046
	1-/3-phase TPE [mm]	-/735	-/723	-/859	-/859	-/903	-/929	-/-
H4	[mm]	-	-	35	35	35	35	35
M		M16	M16	M16	M16	M16	M16	M16

\* 2- and 4-pole TP and TPD pumps from 1.1 to 90 kW are fitted with motors as standard.

\*\* The dimension before the slash applies to the single-head pump, and the dimension after the slash applies to the twin-head pump.

# Performance curves

DN 80  
2-pole, PN 6, 10, 16

## TP, TPD, TPE, TPED 80-XX/2

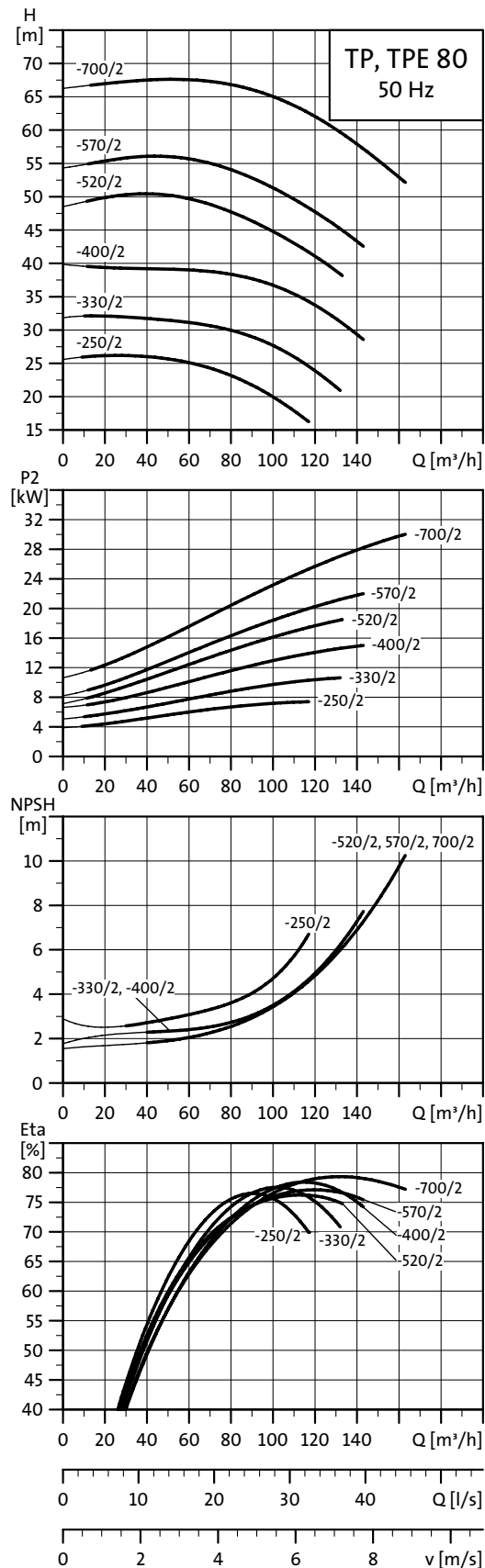
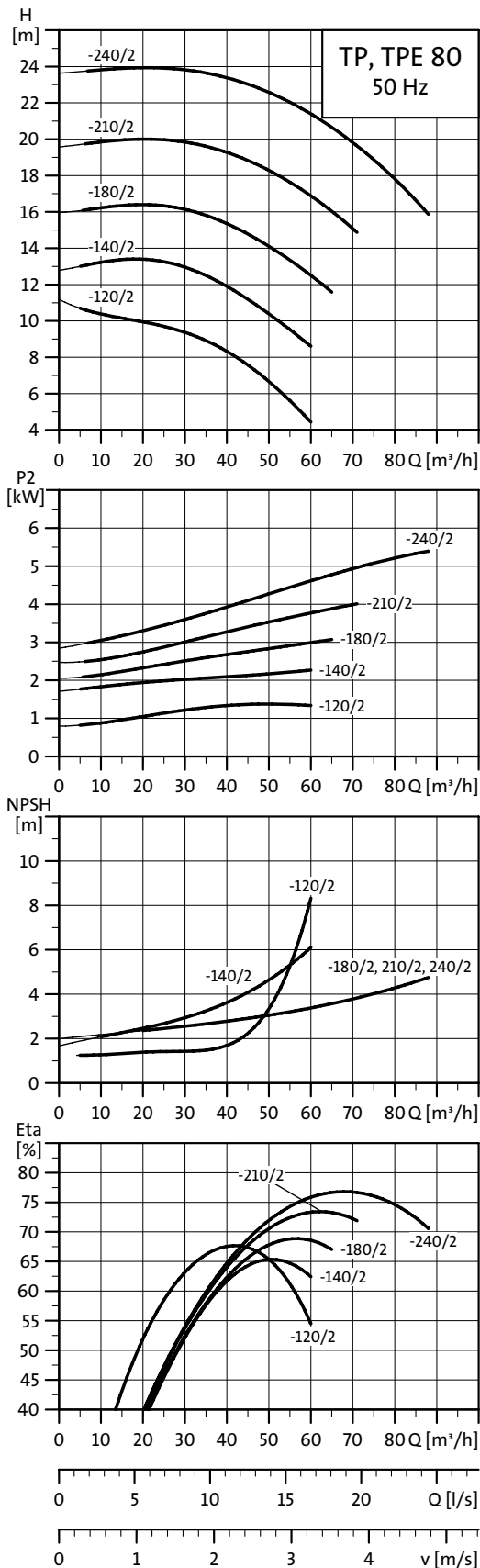

Note: All curves apply to single-head pumps. For further information, see page 49.

TM02 5025 0504

TM02 8750 0904

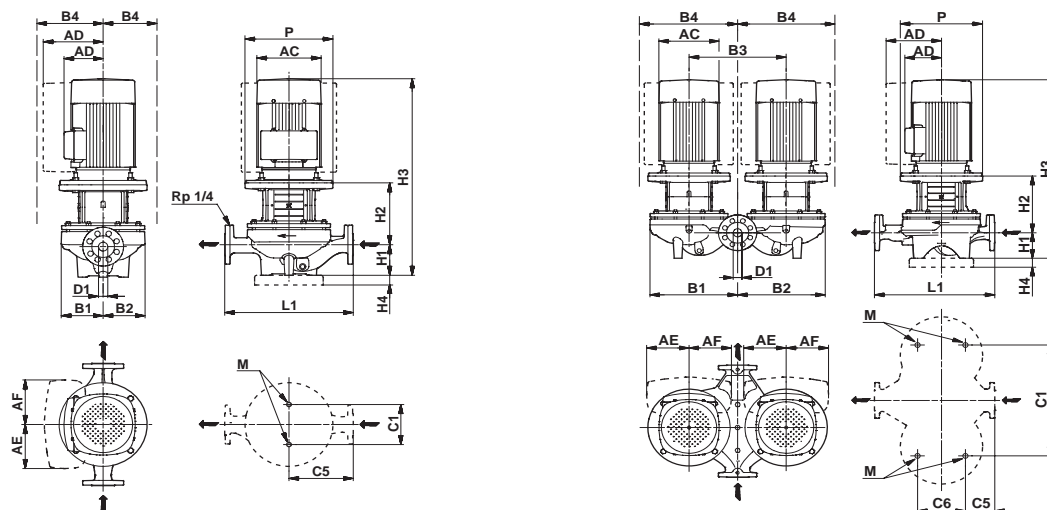

TM03 5348 3406 - TM03 5349 3406

## Technical data

TP 80		-120/2	-140/2	-180/2	-210/2	-240/2	-250/2	-330/2	-400/2	-520/2	-570/2	-700/2
TPD		●	●	●	●	●	●	●	●	●	●	●
TPE		●	●	●	●	●	●	●	●	●	●	-
TPED		●	●	●	●	●	●	●	●	●	●	-
Series		200	300	300	300	300	300	300	300	300	300	300
IEC size	1-phase TP	90	-	-	-	-	-	-	-	-	-	-
	3-phase TP	90	90	100	112	132	132	160	160	160	180	200
	1-phase TPE	-	-	-	-	-	-	-	-	-	-	-
	3-phase TPE	90	90	100	112	132	132	160	160	160	180	-
P2	1-/3-phase TP* [kW]	1.1/1.5	-/2.2	-/3	-/4	-/5.5	-/7.5	-/11	-/15	-/18.5	-/22	-/30
	1-/3-phase TPE [kW]	-/1.5	-/2.2	-/3	-/4	-/5.5	-/7.5	-/11	-/15	-/18.5	-/22	-/
PN		PN 6/PN10	PN 16	PN 16	PN 16	PN 16	PN 16	PN 16	PN 16	PN 16	PN 16	PN 16
T <sub>min</sub> ; T <sub>max</sub>	[°C]	[-25;140]	[-25;120]	[-25;120]	[-25;120]	[-25;120]	[-25;120]	[-25;120]	[-25;120]	[-25;120]	[-25;120]	[-25;120]
D1	[mm]	80	80	80	80	80	80	80	80	80	80	80
AC	1-/3-phase TP [mm]	178/178	-/178	-/198	-/220	-/220	-/220	-/260	-/320	-/320	-/363	-/402
	1-/3-phase TPE [mm]	-/178	-/178	-/198	-/220	-/220	-/260	-/314	-/314	-/314	-/314	-/
AD	1-/3-phase TP [mm]	139/110	-/110	-/120	-/134	-/134	-/134	-/172	-/197	-/197	-/258	-/305
	1-/3-phase TPE [mm]	-/167	-/167	-/177	-/188	-/188	-/213	-/308	-/308	-/308	-/308	-/
AE	1-/3-phase TPE [mm]	-/132	132	132	145	145	145	210	210	210	210	-
AF	1-/3-phase TPE [mm]	-/132	132	132	145	145	145	210	210	210	210	-
P	[mm]	-	200	250	250	300	300	350	350	350	350	400
B1**	[mm]	125/225	125/296	125/296	125/296	125/296	176/366	176/366	176/366	187/416	187/416	187/416
B2**	[mm]	100/235	119/290	119/290	119/290	119/290	144/354	144/354	144/354	162/405	162/405	162/405
B3	[mm]	240	340	340	340	340	400	400	400	470	470	470
	TP [mm]	139/225	125/296	125/296	134/296	150/320	176/366	176/375	197/375	197/416	258/417	305/436
B4**	1-phase TPE [mm]	-	-	-	-	-	-	-	-	-	-	-
	3-phase TPE [mm]	167/320	167/296	177/296	188/395	188/395	213/366	308/538	308/538	308/573	308/573	-
C1**	[mm]	160/240	144/420	144/420	144/420	144/420	144/480	144/480	144/480	144/550	144/550	144/550
C5**	[mm]	180/53	180/78	180/78	180/78	180/78	220/93	220/93	220/93	250/133	250/133	250/133
C6	[mm]	173	175	175	175	175	175	175	175	350	350	350
L1	[mm]	360	360	360	360	360	440	440	440	500	500	500
H1	[mm]	97	105	105	105	105	115	115	115	115	115	115
H2	[mm]	163	176	204	204	243	243	273	273	273	273	273
H3	1-/3-phase TP [mm]	541/541	-/602	-/644	-/681	-/739	-/749	-/852	-/866	-/906	-/990	-/1047
	1-/3-phase TPE [mm]	-/541	-/602	-/644	-/681	-/739	-/737	-/859	-/859	-/903	-/929	-/
H4	[mm]	-	-	-	-	-	-	35	35	35	35	35
M		M16	M16	M16	M16	M16	M16	M16	M16	M16	M16	M16

\* 2- and 4-pole TP and TPD pumps from 1.1 to 90 kW are fitted with motors as standard.

\*\* The dimension before the slash applies to the single-head pump, and the dimension after the slash applies to the twin-head pump.

# Performance curves

DN 100  
2-pole, PN 6, 10, 16

## TP, TPD, TPE, TPED 100-XX/2

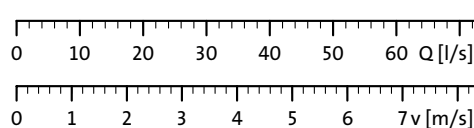
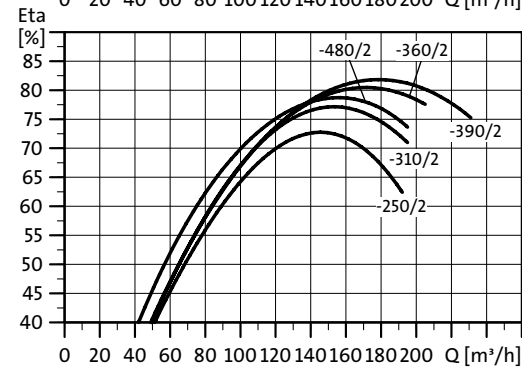
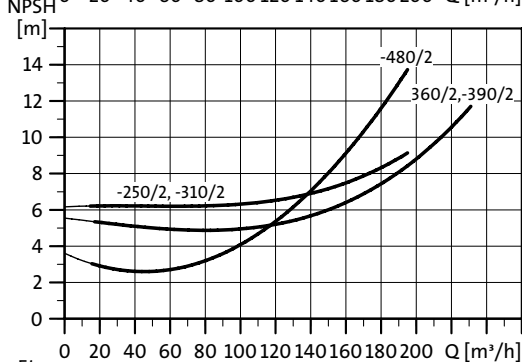
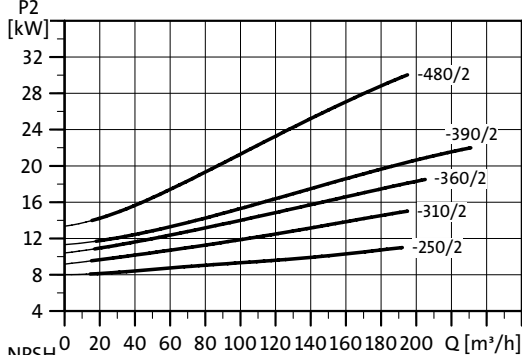
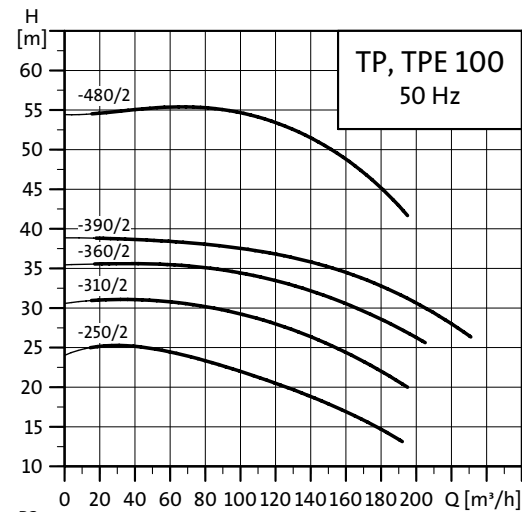
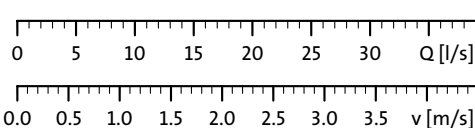
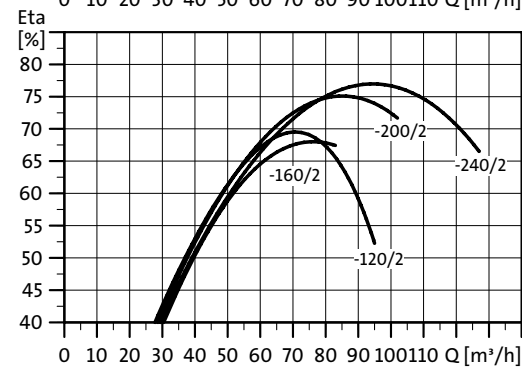
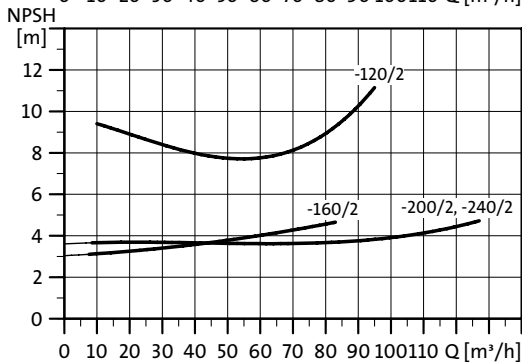
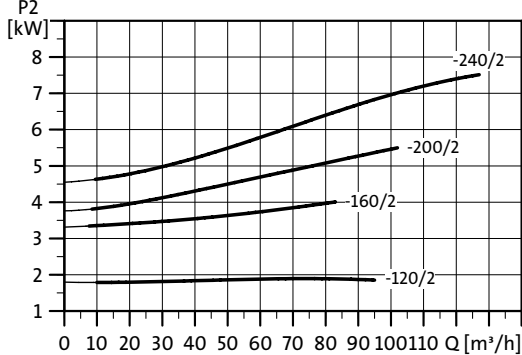
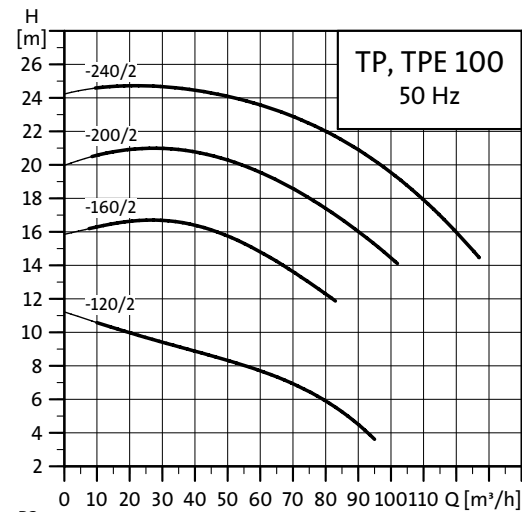

TM02 5026 0504

TM02 8751 0904

**Note:** All curves apply to single-head pumps. For further information, see page 49.

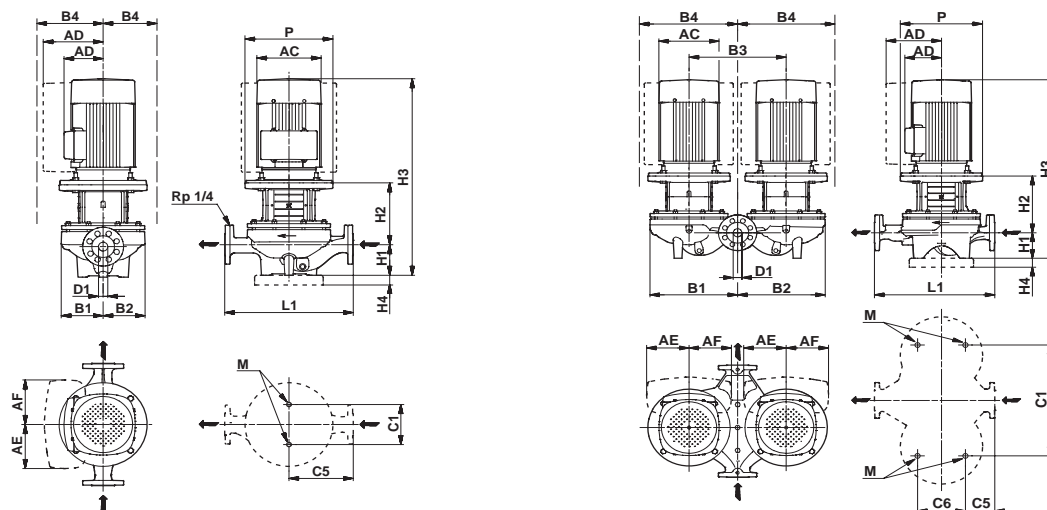

TM03 5348 3406 - TM03 5349 3406

## Technical data

TP 100		-120/2	-160/2	-200/2	-240/2	-250/2	-310/2	-360/2	-390/2	-480/2
TPD		●	●	●	●	●	●	●	●	●
TPE		●	●	●	●	●	●	●	●	-
TPED		●	●	●	●	●	●	●	●	-
Series		200	300	300	300	300	300	300	300	300
IEC size	1-phase TP	-	-	-	-	-	-	-	-	-
	3-phase TP	90	112	132	132	160	160	160	180	200
	1-phase TPE	-	-	-	-	-	-	-	-	-
	3-phase TPE	90	112	132	132	160	160	160	180	-
P2	1-/3-phase TP* [kW]	-/2.2	-/4	-/5.5	-/7.5	-/11	-/15	-/18.5	-/22	-/30
	1-/3-phase TPE [kW]	-/2.2	-/4	-/5.5	-/7.5	-/11	-/15	-/18.5	-/22	-/-
PN		PN 6/PN 10	PN 16	PN 16	PN 16	PN 16	PN 16	PN 16	PN 16	PN 16
T <sub>min</sub> ; T <sub>max</sub>	[°C]	[-25;140]	[-25;120]	[-25;120]	[-25;120]	[-25;120]	[-25;120]	[-25;120]	[-25;120]	[-25;120]
D1	[mm]	100	100	100	100	100	100	100	100	100
AC	1-/3-phase TP [mm]	-/178	-/220	-/220	-/220	-/260	-/320	-/320	-/363	-/402
	1-/3-phase TPE [mm]	-/178	-/220	-/220	-/260	-/314	-/314	-/314	-/314	-/-
AD	1-/3-phase TP [mm]	-/110	-/134	-/134	-/134	-/172	-/197	-/197	-/258	-/305
	1-/3-phase TPE [mm]	-/167	-/188	-/188	-/213	-/308	-/308	-/308	-/308	-/-
AE	1-/3-phase TPE [mm]	-/132	145	145	145	210	210	210	210	-
AF	1-/3-phase TPE [mm]	-/132	145	145	145	210	210	210	210	-
P	[mm]	-	250	300	300	350	350	350	350	400
B1**	[mm]	125/245	156/347	156/347	156/347	190/414	190/414	190/414	190/414	201/443
B2**	[mm]	100/265	124/332	124/332	124/332	151/395	151/395	151/395	151/395	173/429
B3	[mm]	280	470	470	470	500	500	500	500	500
	TP [mm]	125/265	156/360	156/385	156/385	190/425	197/425	197/425	258/432	305/451
B4**	1-phase TPE [mm]	-	-	-	-	-	-	-	-	-
	3-phase TPE [mm]	167/340	188/347	188/350	213/350	308/414	308/414	308/414	308/414	-
C1**	[mm]	160/280	144/480	144/480	144/480	230/550	230/550	230/550	230/550	230/550
C5**	[mm]	225/83	250/104	250/104	250/104	275/110	275/110	275/110	275/110	275/110
C6	[mm]	221	175	175	175	230	230	230	230	230
L1	[mm]	450	500	500	500	550	550	550	550	550
H1	[mm]	107	140	140	140	140	140	140	140	140
H2	[mm]	185	206	245	245	270	270	270	270	307
H3	1-/3-phase TP [mm]	-/613	-/718	-/776	-/776	-/874	-/888	-/928	-/1012	-/1106
	1-/3-phase TPE [mm]	-/613	-/718	-/776	-/764	-/881	-/881	-/925	-/951	-/-
H4	[mm]	-	-	-	-	35	35	35	35	35
M		M16	M16	M16	M16	M16	M16	M16	M16	M16

\* 2- and 4-pole TP and TPD pumps from 1.1 to 90 kW are fitted with  motors as standard.

\*\* The dimension before the slash applies to the single-head pump, and the dimension after the slash applies to the twin-head pump.

# Performance curves

DN 32  
4-pole, PN 6, 10, 16

TP, TPD, TPE, TPED, 4-pole, PN 6, 10, 16

TP, TPD, TPE, TPED 32-XXX/4

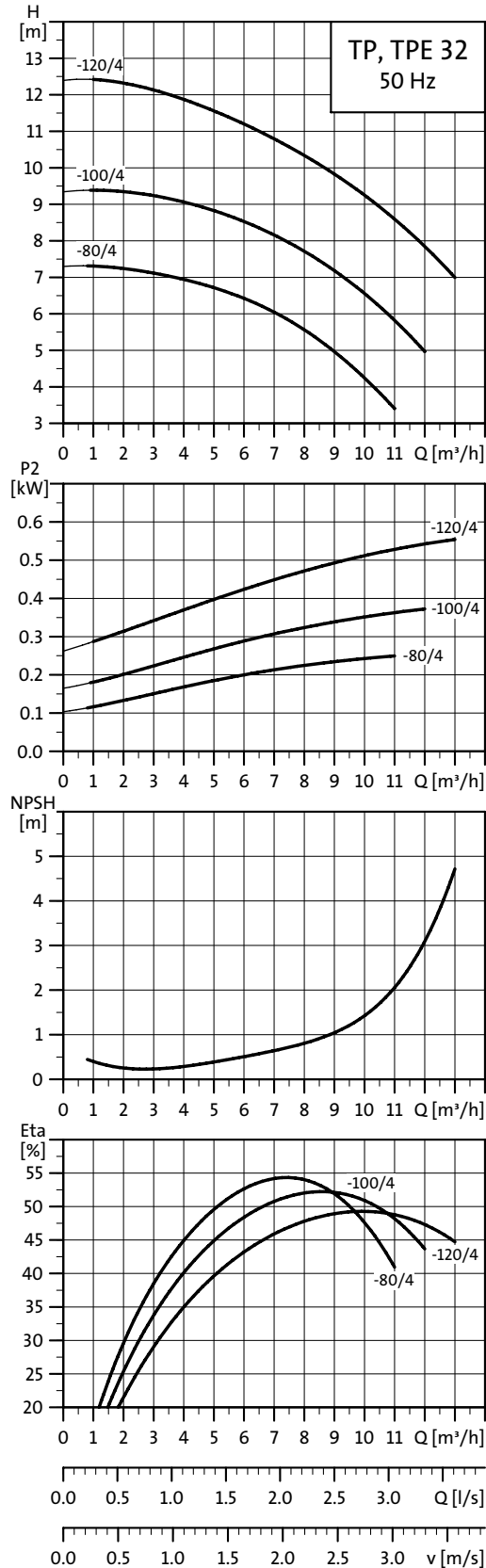
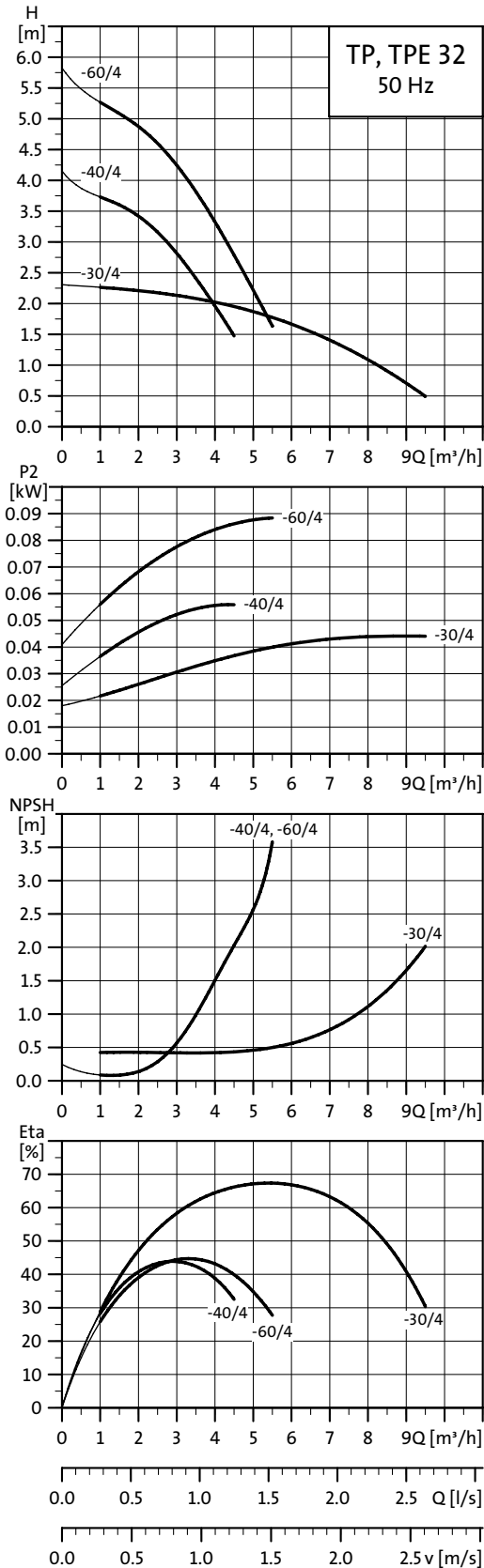

TM02 5027 0504

TM02 5028 0504

Note: All curves apply to single-head pumps. For further information, see page 49.

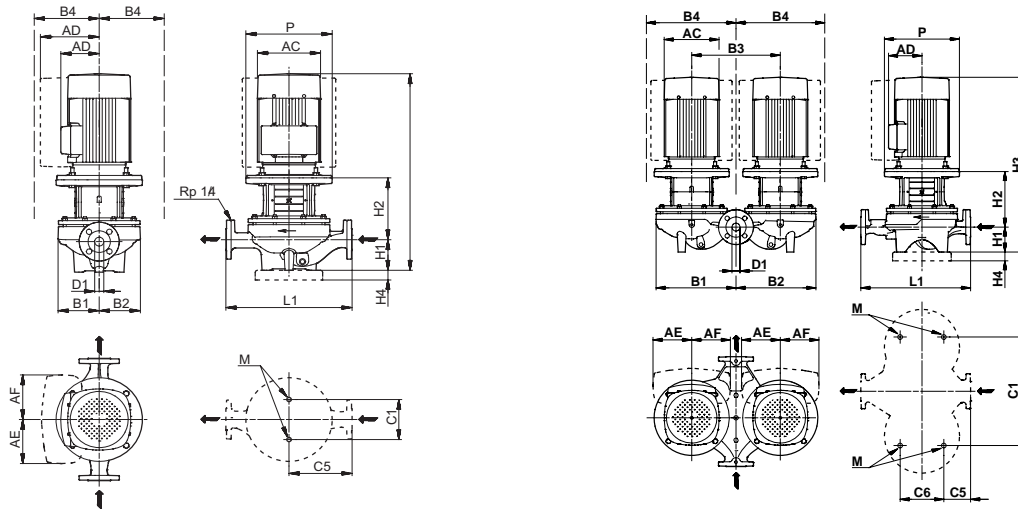

TM02 8632 5004 - TM02 8631 5004

## Technical data

TP 32		-30/4	-40/4	-60/4	-80/4	-100/4	-120/4
TPD		●	●	●	●	●	●
TPE		●	●	●	●	●	●
TPED		●	●	●	●	●	●
Series		200	200	200	300	300	300
IEC size	1-phase TP	63	71	71	-	-	-
	3-phase TP	63	71	71	71	71	80
	1-phase TPE	71	71	71	71	71	80
	3-phase TPE	-	-	-	-	-	80
P2	1-/3-phase TP* [kW]	0.12/0.12	0.18/0.25	0.18/0.25	-/0.25	-/0.37	-/0.55
	1-/3-phase TPE [kW]	0.37/-	0.37/-	0.37/-	0.25/-	0.37/-	0.55/0.55
PN		PN 6/10	PN 6/10	PN 6/10	PN 16	PN 16	PN 16
T <sub>min</sub> ; T <sub>max</sub>	[°C]	[-25;140]	[-25;140]	[-25;140]	[-25;120]	[-25;120]	[-25;120]
D1	[mm]	32	32	32	32	32	32
AC	1-/3-phase TP [mm]	118/118	142/141	142/141	-/141	-/141	-/141
	1-/3-phase TPE [mm]	141/-	141/-	141/-	141/-	141/-	141/178
AD	1-/3-phase TP [mm]	101/101	133/109	133/109	-/109	-/109	-/109
	1-/3-phase TPE [mm]	140/-	140/-	140/-	140/-	140/-	140/167
AE	1-/3-phase TPE [mm]	105/-	105/-	105/-	105/-	105/-	105/132
AF	1-/3-phase TPE [mm]	105/-	105/-	105/-	105/-	105/-	105/132
P	[mm]	-	-	-	170	170	200
B1**	[mm]	75/180	102/222	102/222	125/260	125/260	144/321
B2**	[mm]	75/180	102/222	102/222	117/257	117/257	144/321
B3	[mm]	200	240	240	276	276	355
	TP [mm]	101/180	133/222	133/222	125/260	125/260	144/321
B4**	1-phase TPE [mm]	140/264	140/225	140/225	140/260	140/260	144/321
	3-phase TPE [mm]	-	-	-	-	-	167/321
C1**	[mm]	80/200	80/240	80/240	144/356	144/356	144/435
C5**	[mm]	110/52	140/82	140/82	170/45	170/45	220/46
C6	[mm]	103	103	103	175	175	175
L1	[mm]	220	280	280	340	340	440
H1	[mm]	68	79	79	100	100	100
H2	[mm]	142	125	125	129	129	156
H3	1-/3-phase TP [mm]	416/390	395/395	395/395	-/420	-/420	-/487
	1-/3-phase TPE [mm]	408/-	395/-	395/-	420/-	420/-	487/537
H4	[mm]	-	-	-	-	-	-
M		M12	M12	M12	M16	M16	M16

\* 2- and 4-pole TP and TPD pumps from 1.1 to 90 kW are fitted with motors as standard.

\*\* The dimension before the slash applies to the single-head pump, and the dimension after the slash applies to the twin-head pump.

# Performance curves

DN 40  
4-pole, PN 6, 10, 16

TP, TPD, TPE, TPED 40-XXX/4

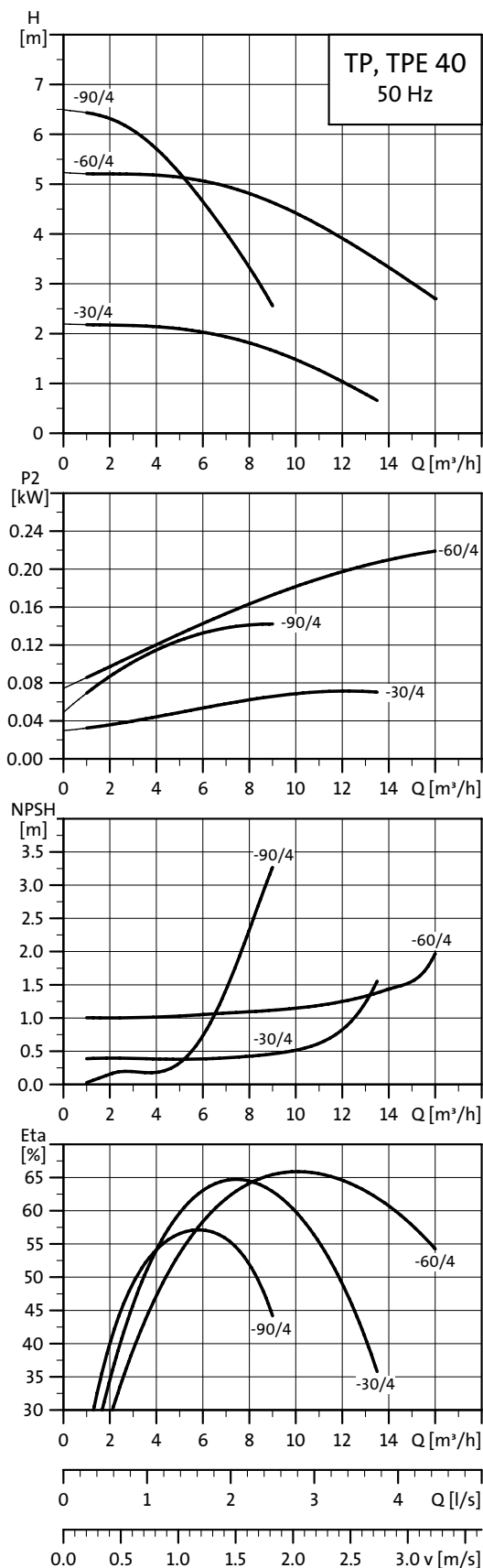

TM02 5029 0504

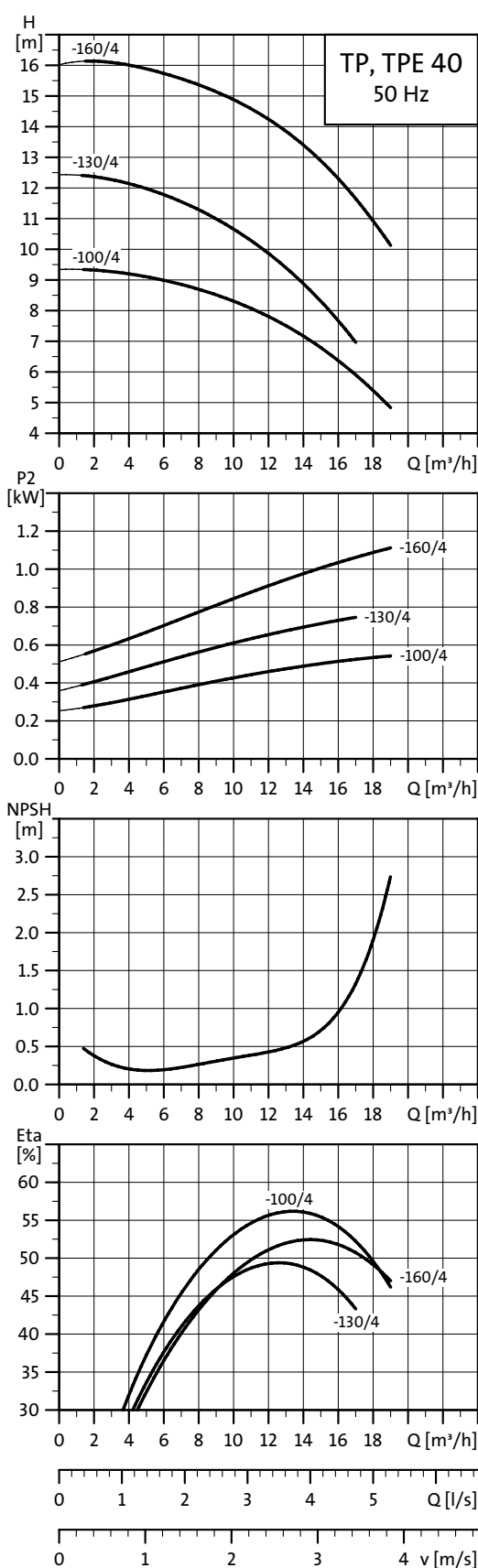

TM02 5030 0504

**Note:** All curves apply to single-head pumps. For further information, see page 49.

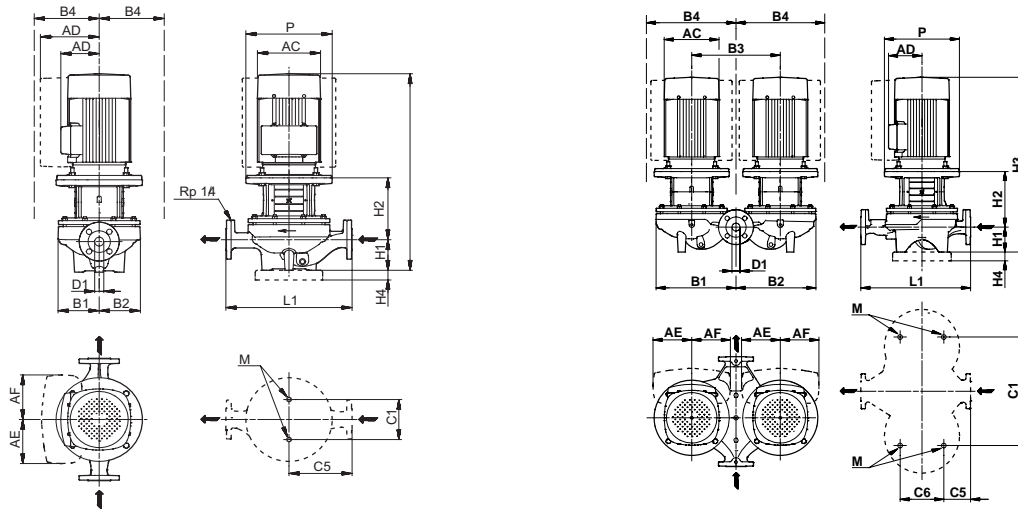

TM02 8632 5004 - TM02 8631 5004

## Technical data

TP 40		-30/4	-60/4	-90/4	-100/4	-130/4	-160/4
TPD		●	-	●	●	●	●
TPE		●	●	●	●	●	●
TPED		●	-	●	●	●	●
Series		200	200	200	300	300	300
IEC size	1-phase TP	63	71	71	-	-	-
	3-phase TP	63	71	71	80	80	90
	1-phase TPE	71	71	71	80	80	-
	3-phase TPE	-	-	-	90	90	90
P2	1-/3-phase TP* [kW]	0.12/0.12	0.25/0.25	0.18/0.25	-/0.55	-/0.75	-/1.1
	1-/3-phase TPE [kW]	0.37/-	0.37/-	0.37/-	0.55/0.55	0.75/0.75	-/1.1
PN		PN 6/10	PN 6/10	PN 16	PN 16	PN 16	PN 16
T <sub>min</sub> ; T <sub>max</sub>	[°C]	[-25;140]	[-25;140]	[-25;140]	[-25;120]	[-25;120]	[-25;120]
D1	[mm]	40	40	40	40	40	40
AC	1-/3-phase TP [mm]	118/118	141/141	141/141	-/141	-/141	-/178
	1-/3-phase TPE [mm]	141/-	141/-	141/-	141/178	141/178	-/178
AD	1-/3-phase TP [mm]	101/101	133/109	133/109	-/109	-/109	-/110
	1-/3-phase TPE [mm]	140/-	140/-	140/-	140/167	140/167	-/167
AE	1-/3-phase TPE [mm]	105/-	105/-	105/-	105/132	105/132	-/132
AF	1-/3-phase TPE [mm]	105/-	105/-	105/-	105/132	105/132	-/132
P	[mm]	-	-	-	200	200	200
B1**	[mm]	85/180	100/-	102/222	130/273	149/325	149/325
B2**	[mm]	75/180	100/-	102/222	117/267	144/321	144/321
B3	[mm]	200	-	240	290	355	355
	TP [mm]	101/180	133/-	133/222	130/273	149/325	149/325
B4**	1-phase TPE [mm]	140/264	140/225	140/225	140/273	149/325	-
	3-phase TPE [mm]	-	-	-	167/277	167/325	167/325
C1**	[mm]	120/200	120/-	120/240	144/400	144/435	144/435
C5**	[mm]	125/45	125/-	160/95	170/45	220/108	220/108
C6	[mm]	125	-	125	175	175	175
L1	[mm]	250	250	320	340	440	440
H1	[mm]	67	75	68	100	110	110
H2	[mm]	146	123	128	166	158	158
H3	1-/3-phase TP [mm]	419/393	389/389	388/388	-/497	-/499	-/549
	1-/3-phase TPE [mm]	411/-	389/-	388/-	507/547	499/549	-/549
H4	[mm]	-	-	-	-	-	-
M		M12	M12	M12	M16	M16	M16

\* 2- and 4-pole TP and TPD pumps from 1.1 to 90 kW are fitted with  motors as standard.

\*\* The dimension before the slash applies to the single-head pump, and the dimension after the slash applies to the twin-head pump.

# Performance curves

DN 50  
4-pole, PN 6, 10, 16

## TP, TPD, TPE, TPED 50-XXX/4

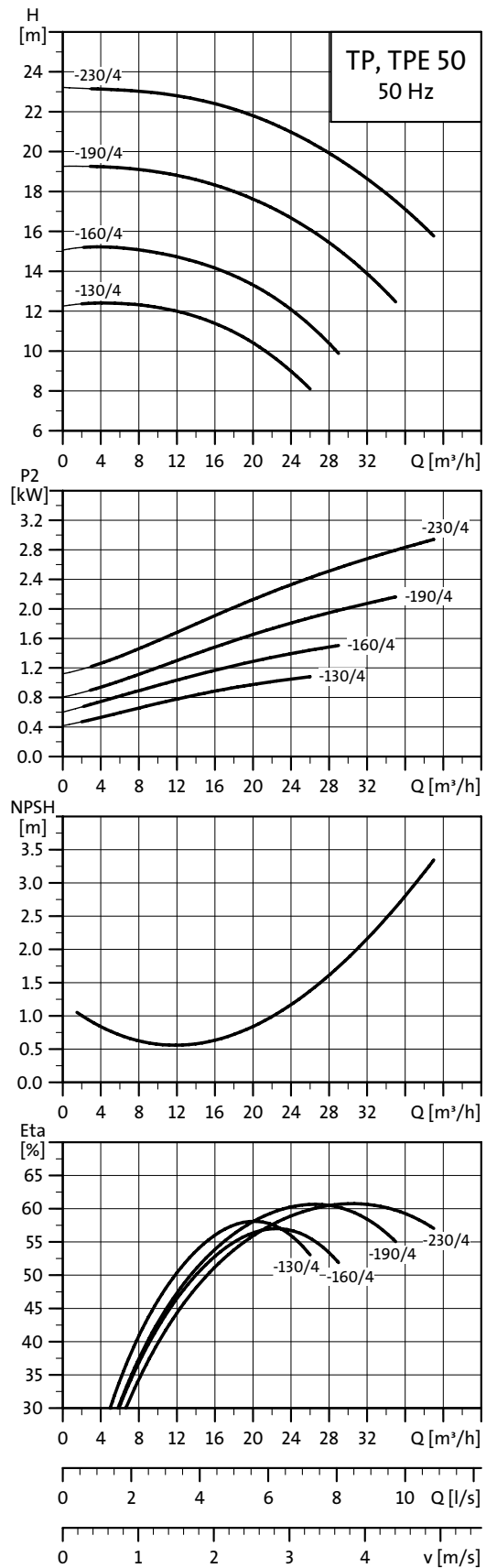
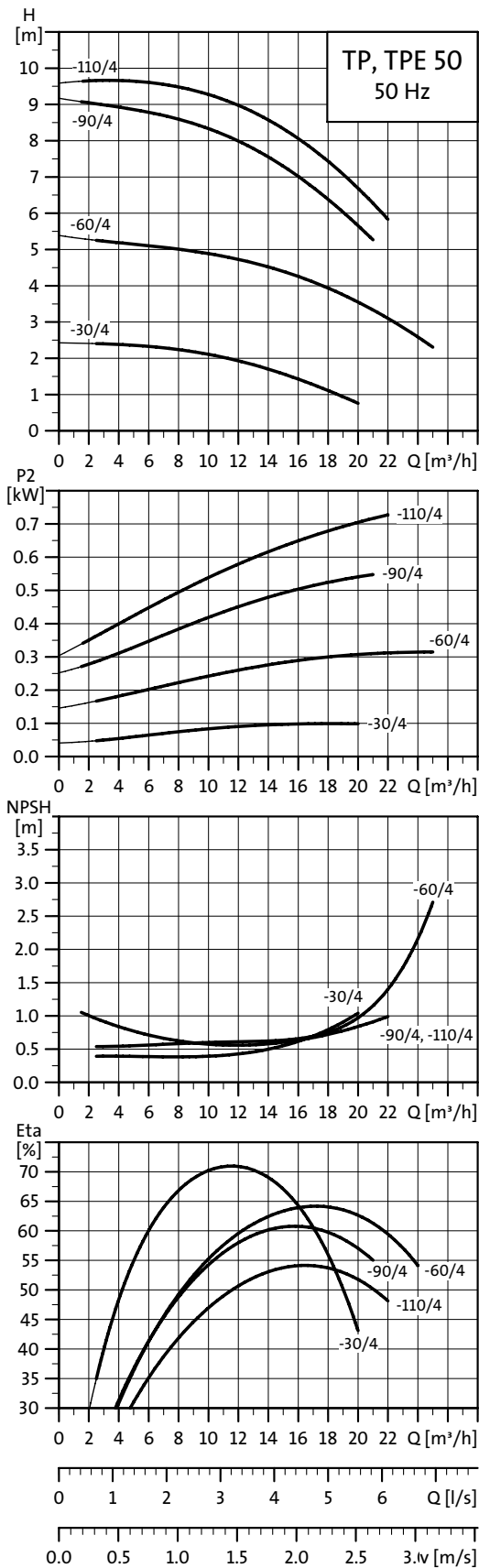

TM02 5031 0504

TM02 5032 0504

**Note:** All curves apply to single-head pumps. For further information, see page 49.

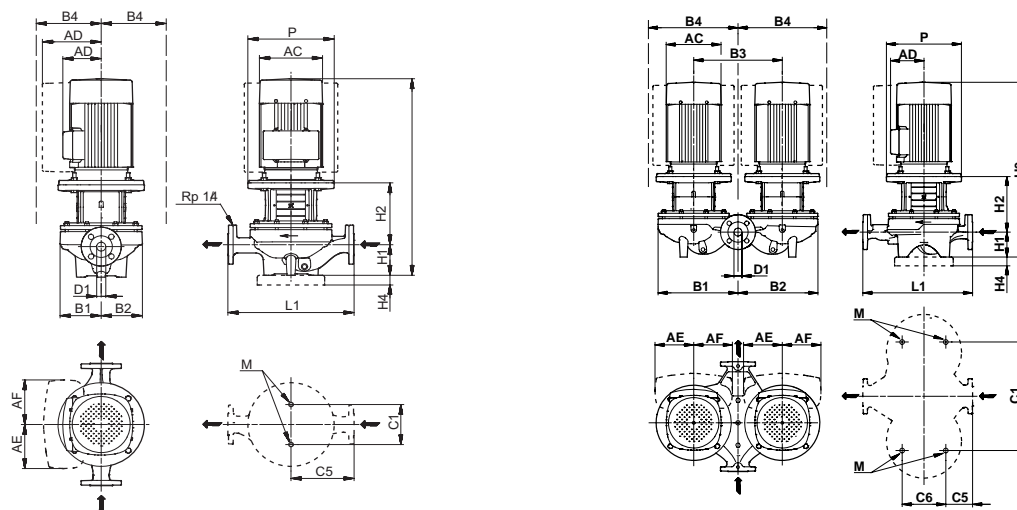

TM02 8632 5004 - TM02 8631 5004

## Technical data

TP 50		-30/4	-60/4	-90/4	-110/4	-130/4	-160/4	-190/4	-230/4
TPD		●	●	●	●	●	●	●	●
TPE		●	●	●	●	●	●	●	●
TPED		●	●	●	●	●	●	●	●
Series		200	200	300	300	300	300	300	300
IEC size	1-phase TP	71	80	-	-	-	-	-	-
	3-phase TP	71	71	80	80	90	90	100	100
	1-phase TPE	71	71	80	80	-	-	-	-
	3-phase TPE	-	-	90	90	90	90	90	90
P2	1-/3-phase TP* [kW]	0.18/0.25	0.37/0.37	-/0.55	-/0.75	-/1.1	-/1.5	-/2.2	-/3
	1-/3-phase TPE [kW]	0.37/-	0.37/-	0.55/0.55	0.75/0.75	-/1.1	-/1.5	-/2.2	-/3
PN		PN 6/10	PN 6/10	PN 16	PN 16	PN 16	PN 16	PN 16	PN 16
T <sub>min</sub> ; T <sub>max</sub>	[°C]	[-25;140]	[-25;140]	[-25;120]	[-25;120]	[-25;120]	[-25;120]	[-25;120]	[-25;120]
D1	[mm]	50	50	50	50	50	50	50	50
AC	1-/3-phase TP [mm]	141/141	141/141	-/141	-/141	-/178	-/178	-/198	-/198
	1-/3-phase TPE [mm]	141/-	141/-	141/178	141/178	-/178	-/178	-/198	-/198
AD	1-/3-phase TP [mm]	133/109	133/109	-/109	-/109	-/110	-/110	-/120	-/120
	1-/3-phase TPE [mm]	140/-	140/-	140/167	140/167	-/167	-/167	-/177	-/177
AE	1-/3-phase TPE [mm]	105/-	105/-	105/132	105/132	-/132	-/132	-/132	-/132
AF	1-/3-phase TPE [mm]	105/-	105/-	105/132	105/132	-/132	-/132	-/132	-/132
P	[mm]	-	-	200	200	200	200	250	250
B1**	[mm]	90/181	110/225	133/290	180/386	180/386	180/386	180/386	180/386
B2**	[mm]	75/186	100/225	119/284	164/379	164/379	164/379	164/379	164/379
B3	[mm]	200	240	320	420	420	420	420	420
B4**	TP [mm]	133/181	133/225	133/290	180/386	180/386	180/386	180/386	180/386
	1-phase TPE [mm]	140/264	140/225	140/290	180/386	-	-	-	-
	3-phase TPE [mm]	-	-	167/290	180/386	180/386	180/386	180/386	180/386
C1**	[mm]	120/200	120/240	144/400	144/500	144/500	144/500	144/500	144/500
C5**	[mm]	140/60	140/60	170/52	220/123	220/123	220/123	220/123	220/123
C6	[mm]	125	125	175	175	175	175	175	175
L1	[mm]	280	280	340	440	440	440	440	440
H1	[mm]	82	82	115	115	115	115	115	115
H2	[mm]	135	127	161	167	167	167	195	195
H3	1-/3-phase TP [mm]	408/408	452/400	-/507	-/513	-/563	-/603	-/645	-/645
	1-/3-phase TPE [mm]	408/-	400/-	507/557	513/563	-/563	-/603	-/645	-/645
H4	[mm]	-	-	-	-	-	-	-	-
M		M12	M12	M16	M16	M16	M16	M16	M16

\* 2- and 4-pole TP and TPD pumps from 1.1 to 90 kW are fitted with motors as standard.

\*\* The dimension before the slash applies to the single-head pump, and the dimension after the slash applies to the twin-head pump.

# Performance curves

DN 65  
4-pole, PN 6, 10, 16

## TP, TPD, TPE, TPED 65-XXX/4

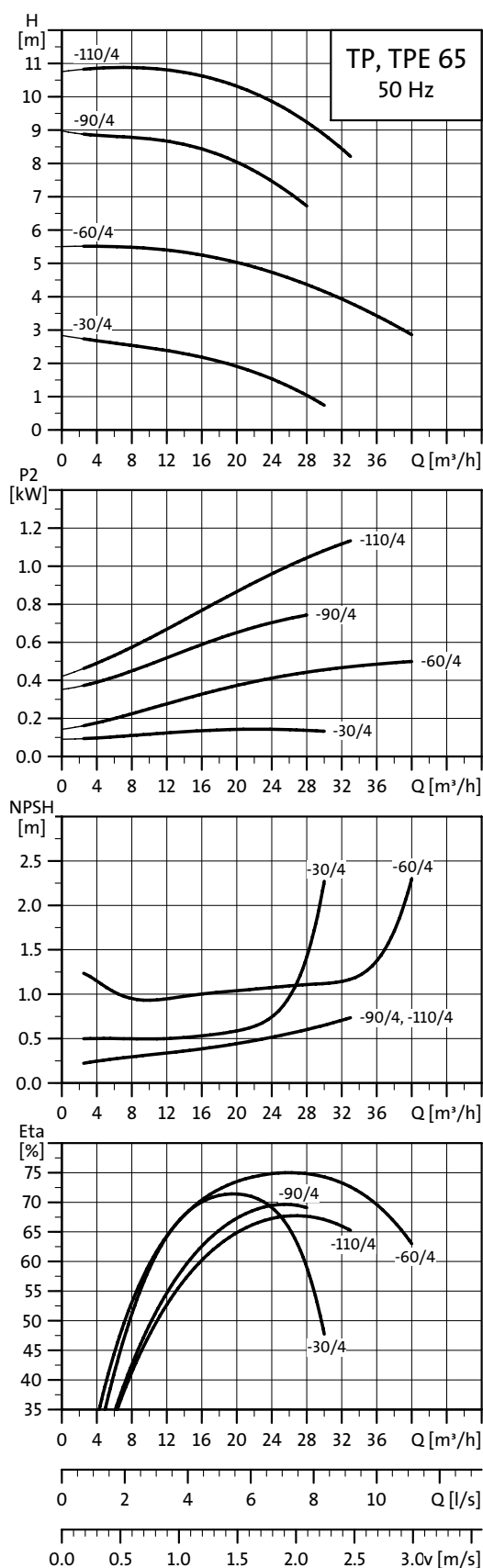

TM02 5033 0504

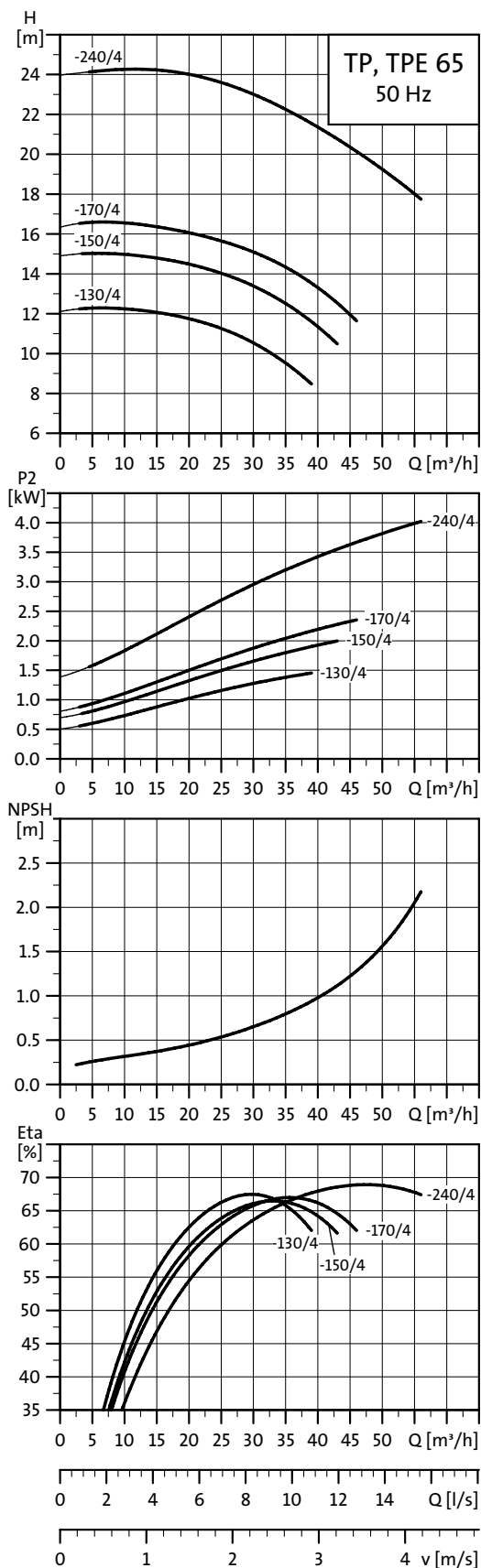

TM02 5043 0504

**Note:** All curves apply to single-head pumps. For further information, see page 49.

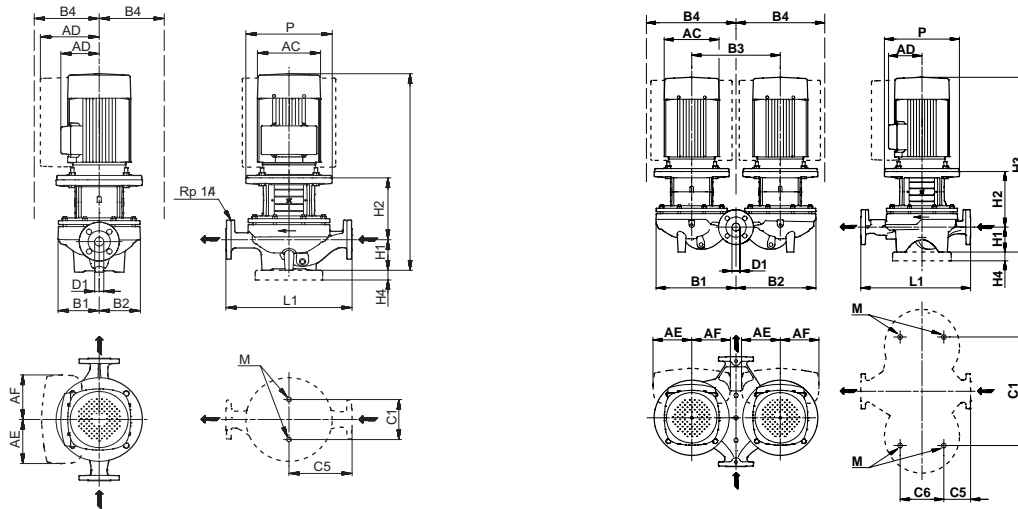

TM02 8632 5004 - TM02 8631 5004

## Technical data

TP 65		-30/4	-60/4	-90/4	-110/4	-130/4	-150/4	-170/4	-240/4
TPD		●	●	●	●	●	●	●	●
TPE		●	●	●	●	●	●	●	●
TPED		●	●	●	●	●	●	●	●
Series		200	200	300	300	300	300	300	300
IEC size	1-phase TP	71	80	-	-	-	-	-	-
	3-phase TP	71	80	80	90	90	100	100	112
	1-phase TPE	71	80	80	-	-	-	-	-
	3-phase TPE	-	90	90	90	90	100	100	112
P2	1-/3-phase TP* [kW]	0.25/0.25	0.55/0.55	-/0.75	-/1.1	-/1.5	-/2.2	-/3	-/4
	1-/3-phase TPE [kW]	0.37/-	0.55/0.55	0.75/0.75	-/1.1	-/1.5	-/2.2	-/3	-/4
PN		PN 6/10	PN 6/10	PN 16	PN 16	PN 16	PN 16	PN 16	PN 16
T <sub>min</sub> ; T <sub>max</sub>	[°C]	[-25;140]	[-25;140]	[-25;120]	[-25;120]	[-25;120]	[-25;120]	[-25;120]	[-25;120]
D1	[mm]	65	65	65	65	65	65	65	65
AC	1-/3-phase TP [mm]	141/141	141/141	-/141	-/178	-/178	-/198	-/198	-/220
	1-/3-phase TPE [mm]	141/-	141/178	141/178	-/178	-/178	-/198	-/198	-/220
AD	1-/3-phase TP [mm]	133/109	133/109	-/109	-/110	-/110	-/120	-/120	-/134
	1-/3-phase TPE [mm]	140/-	140/167	140/167	-/167	-/167	-/177	-/177	-/188
AE	1-/3-phase TPE [mm]	105/-	105/132	105/105	-/132	-/132	-/132	-/132	-/145
AF	1-/3-phase TPE [mm]	105/-	105/132	105/105	-/132	-/132	-/132	-/132	-/145
P	[mm]	-	-	200	200	200	250	250	250
B1**	[mm]	125/230	125/230	142/298	178/349	178/349	178/349	178/349	178/349
B2**	[mm]	100/240	100/240	124/290	164/383	164/383	164/0	164/383	164/383
B3	[mm]	240	240	320	440	440	440	440	440
B4**	TP [mm]	133/240	133/240	142/298	178/383	178/383	178/349	178/383	178/383
	1-phase TPE [mm]	140/240	140/240	142/298	-	-	-	-	-
	3-phase TPE [mm]	-	167/320	167/360	178/383	178/383	178/383	178/383	188/365
C1**	[mm]	160/240	160/240	144/400	144/520	144/520	144/520	144/520	144/520
C5**	[mm]	170/63	170/63	180/65	238/111	238/111	238/111	238/111	238/111
C6	[mm]	153	153	175	175	175	175	175	175
L1	[mm]	340	340	360	475	475	475	475	475
H1	[mm]	97	97	105	125	125	125	125	125
H2	[mm]	135	147	172	166	166	194	194	194
H3	1-/3-phase TP [mm]	423/423	475/475	-/508	-/572	-/612	-/654	-/654	-/691
	1-/3-phase TPE [mm]	423/-	475/525	508/558	-/572	-/612	-/654	-/654	-/691
H4	[mm]	-	-	-	-	-	-	-	-
M		M16	M16	M16	M16	M16	M16	M16	M16

\* 2- and 4-pole TP and TPD pumps from 1.1 to 90 kW are fitted with **EFF I** motors as standard.

\*\* The dimension before the slash applies to the single-head pump, and the dimension after the slash applies to the twin-head pump.

# Performance curves

DN 80  
4-pole, PN 6, 10, 16

## TP, TPD, TPE, TPED 80-XXX/4

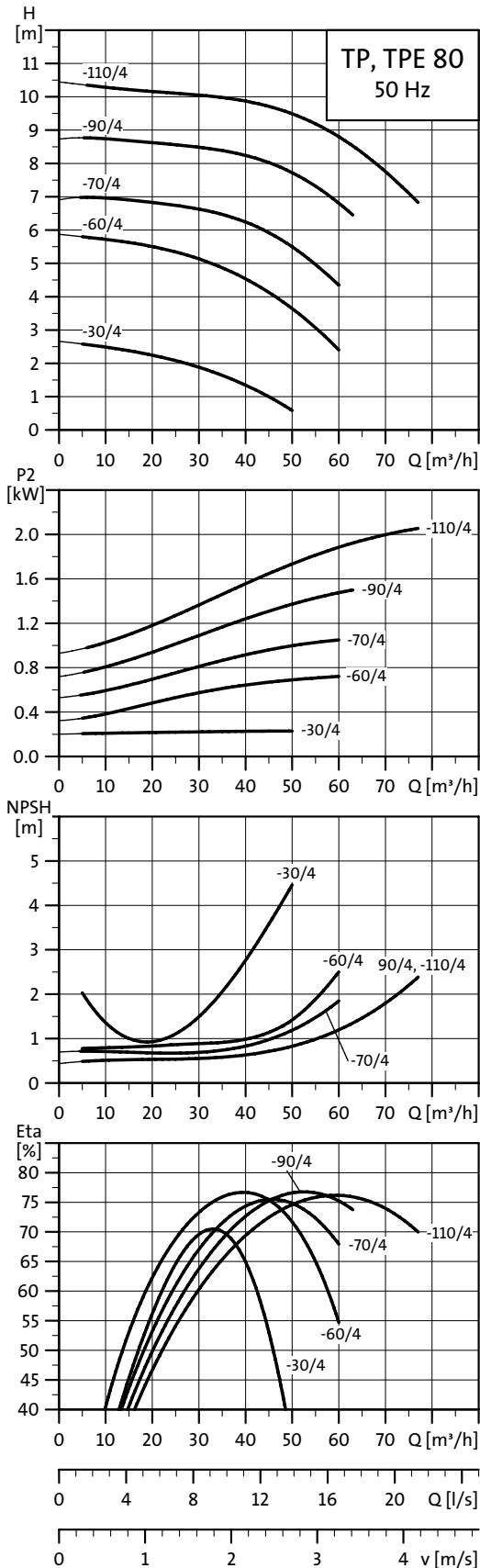

TM02 5044 0504

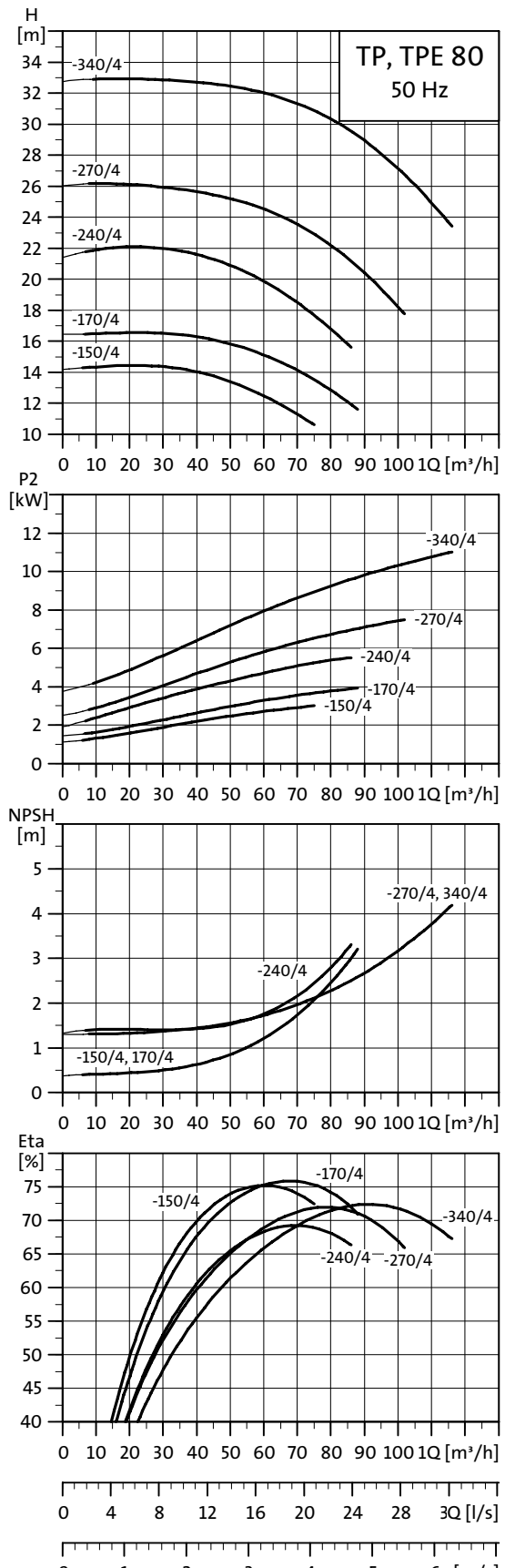

TM02 8752 3208

**Note:** All curves apply to single-head pumps. For further information, see page 49.

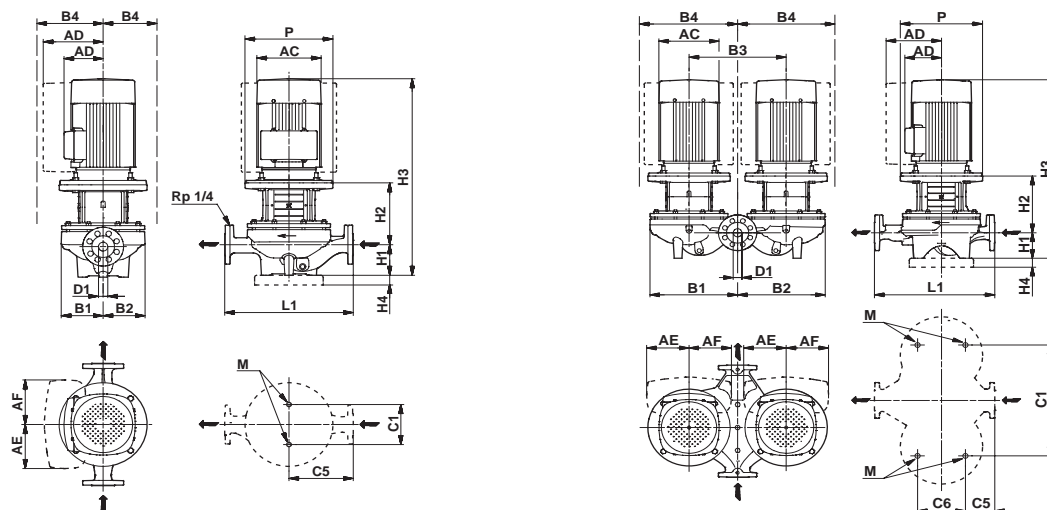

TM03 5348 3406 - TM03 5349 3406

## Technical data

TP 80		-30/4	-60/4	-70/4	-90/4	-110/4	-150/4	-170/4	-240/4	-270/4	-340/4
TPD		●	●	●	●	●	●	●	●	●	●
TPE		●	●	●	●	●	●	●	●	●	●
TPED		●	●	●	●	●	●	●	●	●	●
Series		200	200	300	300	300	300	300	300	300	300
IEC size	1-phase TP	80	90	-	-	-	-	-	-	-	-
	3-phase TP	71	80	90	90	100	100	112	132	132	160
	1-phase TPE	71	80	-	-	-	-	-	-	-	-
	3-phase TPE	-	90	90	90	100	112	112	132	132	160
P2	1-/3-phase TP* [kW]	0.37/0.37	0.75/0.75	-1.1	-1.5	-2.2	-3	-4	-5.5	-7.5	-11
	1-/3-phase TPE [kW]	0.37/-	0.75/0.75	-1.1	-1.5	-2.2	-3	-4	-5.5	-7.5	-11
PN		PN 6/PN 10	PN 6/PN 10	PN 16	PN 16	PN 16	PN 16	PN 16	PN 16	PN 16	PN 16
T <sub>min</sub> ; T <sub>max</sub>	[°C]	[-25;140]	[-25;140]	[-25;120]	[-25;120]	[-25;120]	[-25;120]	[-25;120]	[-25;120]	[-25;120]	[-25;120]
D1	[mm]	80	80	80	80	80	80	80	80	80	80
AC	1-/3-phase TP [mm]	142/141	178/141	-178	-178	-198	-198	-220	-260	-260	-314
	1-/3-phase TPE [mm]	141/-	141/178	-178	-178	-198	-198	-220	-260	-260	-314
AD	1-/3-phase TP [mm]	133/109	139/109	-110	-110	-120	-120	-134	-159	-159	-204
	1-/3-phase TPE [mm]	140/-	140/167	-167	-167	-177	-177	-188	-213	-213	-308
AE	1-/3-phase TPE [mm]	105/-	105/132	132	132	132	132	145	145	145	210
AF	1-/3-phase TPE [mm]	105/-	105/132	132	132	132	132	145	145	145	210
P	[mm]	-	-	200	200	250	250	250	300	300	350
B1**	[mm]	130/230	135/240	176/366	176/366	176/366	187/416	187/416	243/491	243/491	243/491
B2**	[mm]	100/240	100/250	144/354	144/354	144/354	162/405	162/405	226/480	226/480	226/480
B3	[mm]	240	240	400	400	400	470	470	500	500	500
	TP [mm]	133/230	139/240	176/366	176/366	176/366	187/416	187/416	243/491	243/491	243/491
B4**	1-phase TPE [mm]	140/240	140/250	-	-	-	-	-	-	-	-
	3-phase TPE [mm]	-	167/320	176/366	176/366	177/366	187/416	188/416	243/491	243/491	308/491
C1**	[mm]	160/240	160/240	144/480	144/480	144/480	144/550	144/550	230/550	230/550	230/550
C5**	[mm]	180/53	180/53	220/93	220/93	220/93	250/133	250/133	310/105	310/105	310/105
C6	[mm]	173	173	175	175	175	175	175	350	350	350
	[mm]	360	360	440	440	440	500	500	620	620	620
H1	[mm]	107	107	115	115	115	115	115	140	140	140
H2	[mm]	163	153	176	176	204	204	204	273	273	303
H3	1-/3-phase TP [mm]	513/461	551/491	-572	-612	-654	-654	-691	-792	-842	-914
	1-/3-phase TPE [mm]	461/-	491/541	-572	-612	-654	-654	-691	-792	-872	-914
H4	[mm]	-	-	-	-	-	-	-	-	-	35
M		M16	M16	M16	M16	M16	M16	M16	M16	M16	M16

\* 2- and 4-pole TP and TPD pumps from 1.1 to 90 kW are fitted with  motors as standard.

\*\* The dimension before the slash applies to the single-head pump, and the dimension after the slash applies to the twin-head pump.

# Performance curves

DN 100  
4-pole, PN 6, 10, 16

## TP, TPD, TPE, TPED 100-XXX/4

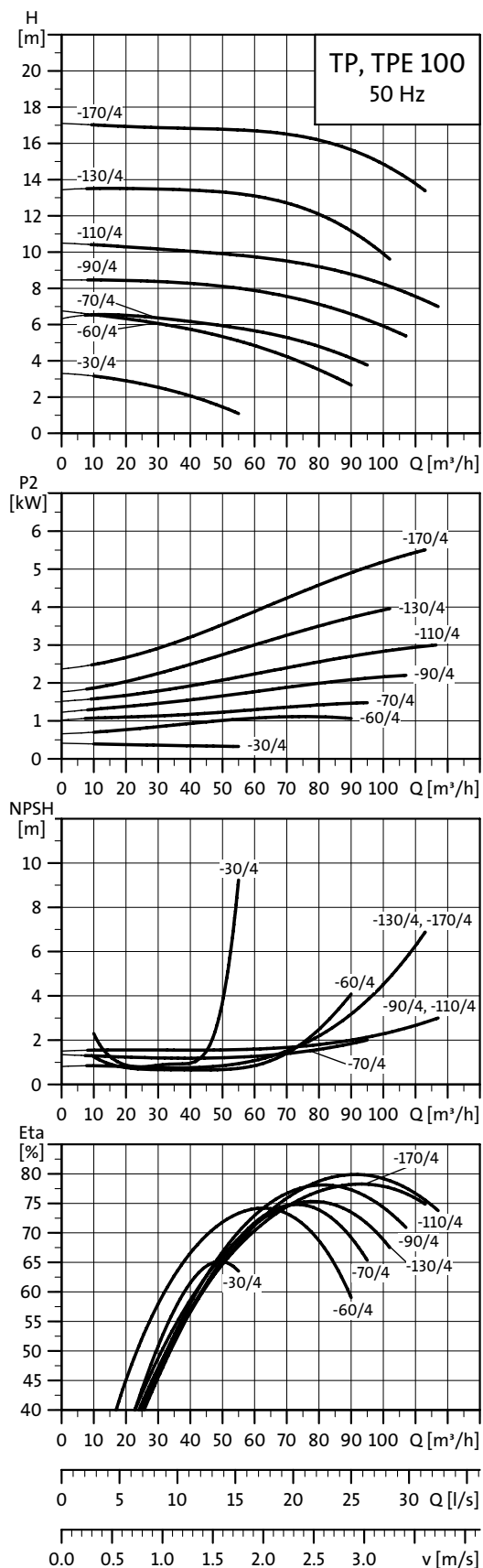

TM02 5045 0504

**Note:** All curves apply to single-head pumps. For further information, see page 49.

# Technical data

DN 100  
4-pole, PN 6, 10, 16

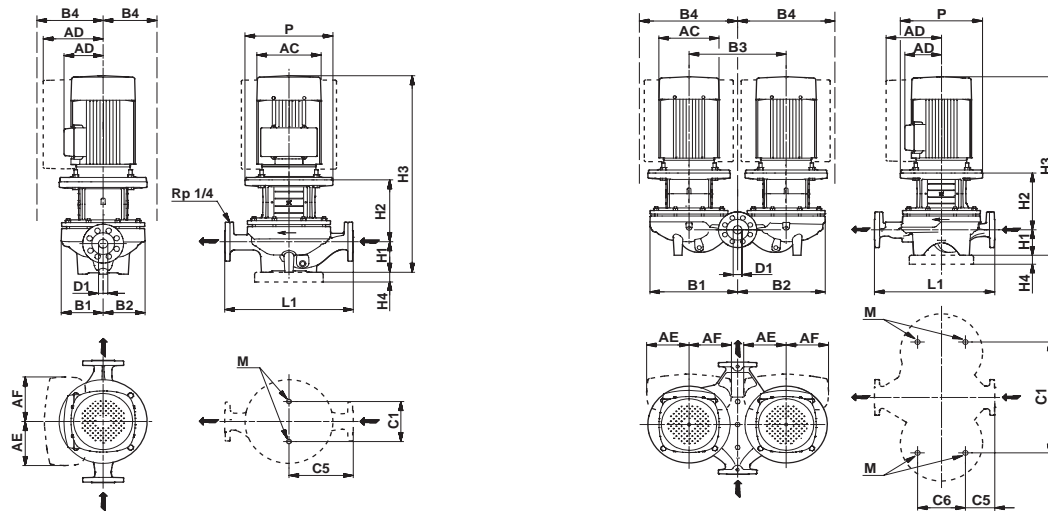

TM03 5348 3406 - TM03 5349 3406

## Technical data

TP 100		-30/4	-60/4	-70/4	-90/4	-110/4	-130/4	-170/4
TPD		●	●	●	●	●	●	●
TPE		●	●	●	●	●	●	●
TPED		●	●	●	●	●	●	●
Series		200	200	300	300	300	300	300
IEC size	1-phase TP	80	90	-	-	-	-	-
	3-phase TP	80	90	90	100	100	112	132
	1-phase TPE	80	-	-	-	-	-	-
	3-phase TPE	90	90	90	100	112	112	132
P2	1-/3-phase TP* [kW]	0.55/0.55	1.1/1.1	-1.5	-2.2	-3	-4	-5.5
	1-/3-phase TPE [kW]	0.55/0.55	-1.1	-1.5	-2.2	-3	-4	-5.5
PN		PN 6/PN 10	PN 6/PN 10	PN 16	PN 16	PN 16	PN 16	PN 16
T <sub>min</sub> ; T <sub>max</sub>	[°C]	[-25;140]	[-25;140]	[-25;120]	[-25;120]	[-25;120]	[-25;120]	[-25;120]
D1	[mm]	100	100	100	100	100	100	100
AC	1-/3-phase TP [mm]	141/141	178/178	-178	-198	-198	-220	-260
	1-/3-phase TPE [mm]	141/178	-178	-178	-198	-198	-220	-260
AD	1-/3-phase TP [mm]	133/109	139/110	-110	-120	-120	-134	-159
	1-/3-phase TPE [mm]	140/167	-167	-167	-177	-177	-188	-213
AE	1-/3-phase TPE [mm]	105/132	-132	132	132	132	145	145
AF	1-/3-phase TPE [mm]	105/132	-132	132	132	132	145	145
P	[mm]	-	-	200	200	200	250	300
B1**	[mm]	175/280	175/280	190/414	190/414	190/414	201/443	201/443
B2**	[mm]	125/305	125/305	151/395	151/395	151/395	173/429	173/429
B3	[mm]	280	280	470	470	470	500	500
	TP [mm]	175/280	175/280	190/414	190/414	190/414	201/443	201/443
B4**	1-phase TPE [mm]	175/305	-	-	-	-	-	-
	3-phase TPE [mm]	175/340	175/340	190/414	190/414	190/414	201/443	213/443
C1**	[mm]	200/280	200/280	230/550	230/550	230/550	230/550	230/550
C5**	[mm]	225/83	225/83	250/110	275/110	275/110	275/110	275/110
C6	[mm]	221	221	230	230	230	230	230
L1	[mm]	450	450	550	550	550	550	550
H1	[mm]	122	122	140	140	140	140	140
H2	[mm]	172	182	173	201	201	261	277
H3	1-/3-phase TP [mm]	525/525	625/585	-634	-676	-676	-773	-796
	1-/3-phase TPE [mm]	525/575	-585	-634	-676	-676	-773	-796
H4	[mm]	-	-	-	-	-	-	-
M		M16	M16	M16	M16	M16	M16	M16

\* 2- and 4-pole TP and TPD pumps from 1.1 to 90 kW are fitted with **EFFI** motors as standard.

\*\* The dimension before the slash applies to the single-head pump, and the dimension after the slash applies to the twin-head pump.

## TP, TPD, TPE, TPED 100-XXX/4

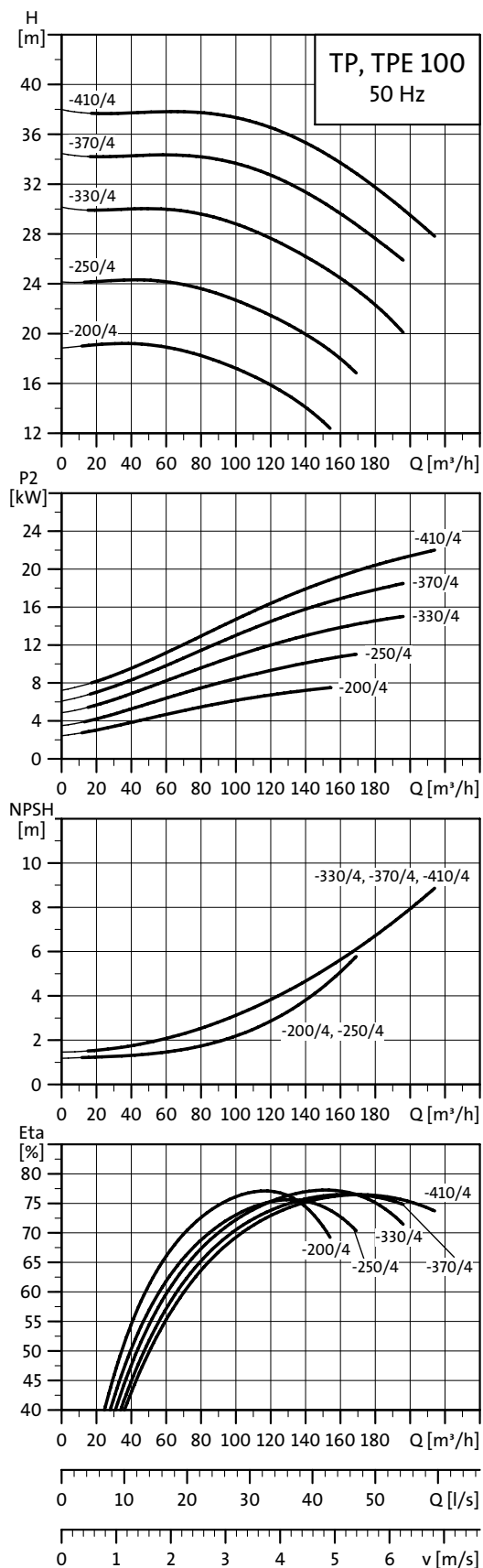

TM02 8753 0904

**Note:** All curves apply to single-head pumps. For further information, see page 49.

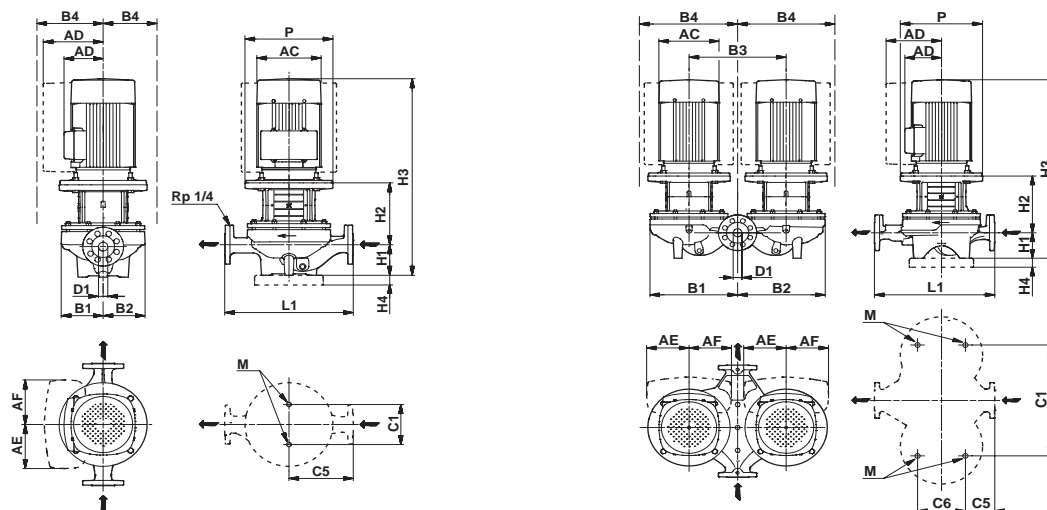

TM03 5348 3406 - TM03 5349 3406

## Technical data

TP 100		-200/4	-250/4	-330/4	-370/4	-410/4
TPD		●	●	●	●	●
TPE		●	●	●	●	-
TPED		●	●	●	●	-
Series		300	300	300	300	300
IEC size	1-phase TP	-	-	-	-	-
	3-phase TP	132	160	160	180	180
	1-phase TPE	-	-	-	-	-
	3-phase TPE	132	160	160	180	-
P2	1-/3-phase TP* [kW]	-/7.5	-/11	-/15	-/18.5	-/22
	1-/3-phase TPE [kW]	-/7.5	-/11	-/15	-/18.5	-
PN		PN 16	PN 16	PN 16	PN 16	PN 16
T <sub>min</sub> ; T <sub>max</sub>	[°C]	[-25;120]	[-25;120]	[-25;120]	[-25;120]	[-25;120]
D1	[mm]	100	100	100	100	100
AC	1-/3-phase TP [mm]	-/260	-/314	-/314	-/363	-/363
	1-/3-phase TPE [mm]	-/260	-/314	-/314	-/314	-
AD	1-/3-phase TP [mm]	-/159	-/204	-/204	-/258	-/258
	1-/3-phase TPE [mm]	-/213	-/308	-/308	-/308	-
AE	1-/3-phase TPE [mm]	145	210	210	210	-
AF	1-/3-phase TPE [mm]	145	210	210	210	-
P	[mm]	300	350	350	350	350
B1**	[mm]	290/579	290/579	290/579	290/579	290/579
B2**	[mm]	249/561	249/561	249/561	249/561	249/561
B3	[mm]	600	600	600	600	600
	TP [mm]	290/579	290/579	290/579	290/579	290/579
B4**	1-phase TPE [mm]	-	-	-	-	-
	3-phase TPE [mm]	290/579	308/579	308/579	308/579	-
C1**	[mm]	230/680	230/680	230/680	230/680	230/680
C5**	[mm]	335/110	335/110	335/110	335/110	335/110
C6	[mm]	350	350	350	350	350
L1	[mm]	670	670	670	670	670
H1	[mm]	175	175	175	175	175
H2	[mm]	254	308	308	308	308
H3	1-/3-phase TP [mm]	-/858	-/954	-/998	-/1085	-/1085
	1-/3-phase TPE [mm]	-/888	-/954	-/998	-/1024	-
H4	[mm]	-	35	35	35	35
M		M16	M16	M16	M16	M16

\* 2- and 4-pole TP and TPD pumps from 1.1 to 90 kW are fitted with  motors as standard.

\*\* The dimension before the slash applies to the single-head pump, and the dimension after the slash applies to the twin-head pump.

# Performance curves

DN 125  
4-pole, PN 6, 10, 16

TP, TPD, TPE, TPED 125-XXX/4

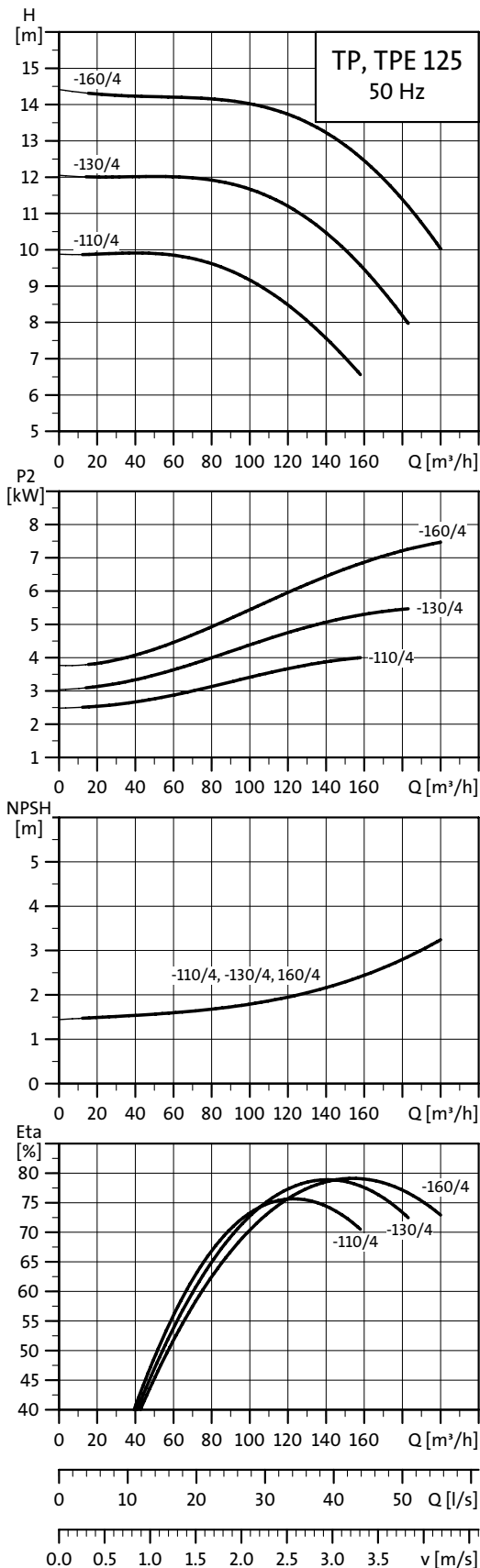

TM02 8755 0904

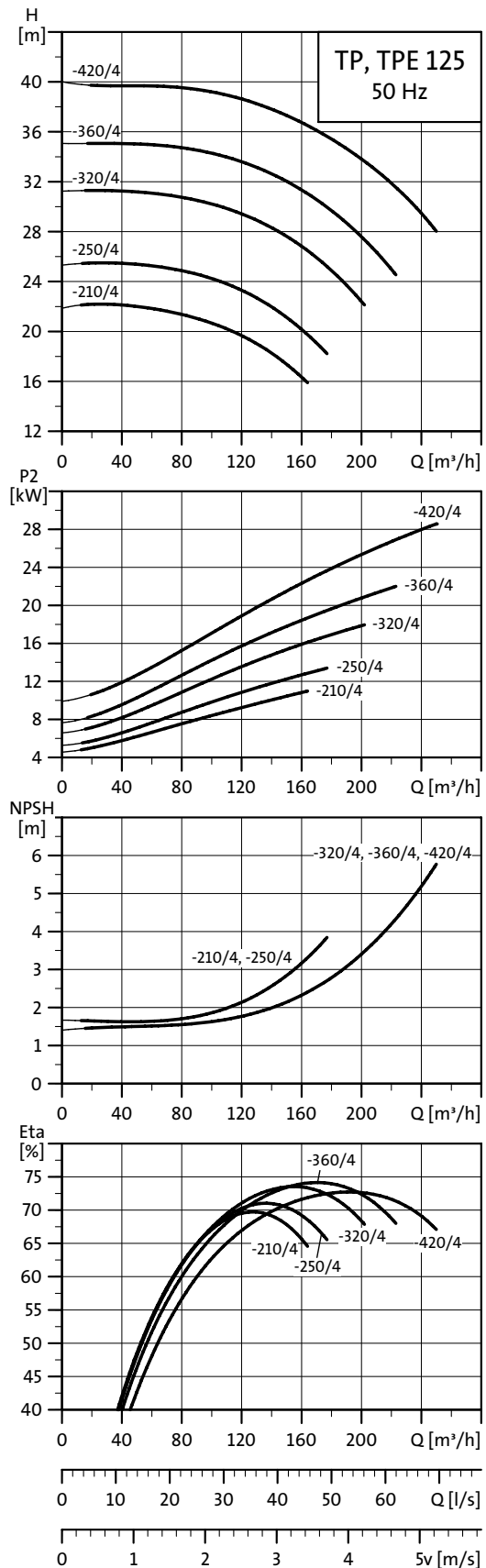

TM02 8756 0904

**Note:** All curves apply to single-head pumps. For further information, see page 49.

# Technical data

DN 125  
4-pole, PN 6, 10, 16

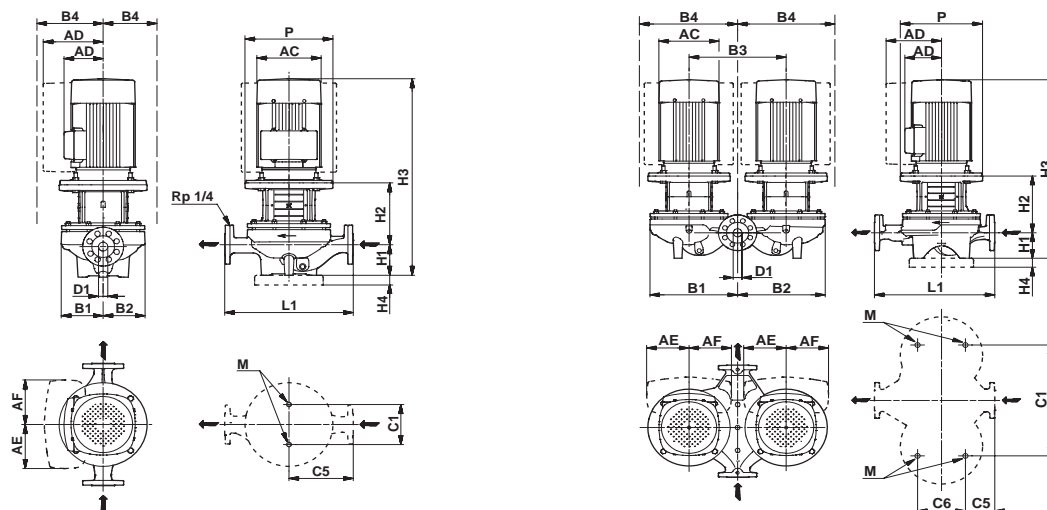

TM03 5348 3406 - TM03 5349 3406

## Technical data

TP 125		-110/4	-130/4	-160/4	-210/4	-250/4	-320/4	-360/4	-420/4
TPD		●	●	●	●	●	●	●	●
TPE		●	●	●	●	●	●	-	-
TPED		●	●	●	●	●	●	-	-
Series		300	300	300	300	300	300	300	300
IEC size	1-phase TP	-	-	-	-	-	-	-	-
	3-phase TP	112	132	132	160	160	180	180	200
	1-phase TPE	-	-	-	-	-	-	-	-
	3-phase TPE	112	132	132	160	160	180	-	-
P2	1-/3-phase TP* [kW]	-/4	-/5.5	-/7.5	-/11	-/15	-/18.5	-/22	-/30
	1-/3-phase TPE [kW]	-/4	-/5.5	-/7.5	-/11	-/15	-/18.5	-	-/
PN		PN 16	PN 16	PN 16	PN 16	PN 16	PN 16	PN 16	PN 16
T <sub>min</sub> ; T <sub>max</sub>	[°C]	[-25;120]	[-25;120]	[-25;120]	[-25;120]	[-25;120]	[-25;120]	[-25;120]	[-25;120]
D1	[mm]	125	125	125	125	125	125	125	125
AC	1-/3-phase TP [mm]	-/220	-/260	-/260	-/314	-/314	-/363	-/363	-/402
	1-/3-phase TPE [mm]	-/220	-/260	-/260	-/314	-/314	-/314	-	-/
AD	1-/3-phase TP [mm]	-/134	-/159	-/159	-/204	-/204	-/258	-/258	-/305
	1-/3-phase TPE [mm]	-/188	-/213	-/213	-/308	-/308	-/308	-	-/
AE	1-/3-phase TPE [mm]	145	145	145	210	210	210	-	-
AF	1-/3-phase TPE [mm]	145	145	145	210	210	210	-	-
P	[mm]	250	300	300	350	350	350	350	400
B1**	[mm]	250/537	250/537	250/537	271/566	271/566	271/566	271/566	271/566
B2**	[mm]	202/518	202/518	202/518	243/552	243/552	243/552	243/552	243/552
B3	[mm]	600	600	600	600	600	600	600	600
	TP [mm]	250/537	250/537	250/537	271/566	271/566	271/566	271/566	305/566
B4**	1-phase TPE [mm]	-	-	-	-	-	-	-	-
	3-phase TPE [mm]	250/537	250/537	250/537	308/566	308/566	308/566	-	-
C1**	[mm]	230/680	230/680	230/680	230/680	230/680	230/680	230/680	
C5**	[mm]	310/84	310/84	310/84	400/175	400/175	400/175	400/175	
C6	[mm]	300	300	300	350	350	350	350	
L1	[mm]	620	620	620	800	800	800	800	
H1	[mm]	215	215	215	215	215	215	215	
H2	[mm]	267	283	283	318	318	318	318	
H3	1-/3-phase TP [mm]	-/854	-/877	-/927	-/1004	-/1048	-/1135	-/1135	-/1192
	1-/3-phase TPE [mm]	-/854	-/877	-/969	-/1004	-/1048	-/1074	-/	-/
H4	[mm]	-	-	-	35	35	35	35	
M		M16	M16	M16	M16	M16	M16	M16	

\* 2- and 4-pole TP and TPD pumps from 1.1 to 90 kW are fitted with motors as standard.

\*\* The dimension before the slash applies to the single-head pump, and the dimension after the slash applies to the twin-head pump.

## TP, TPD, TPE, TPED 150-XXX/4

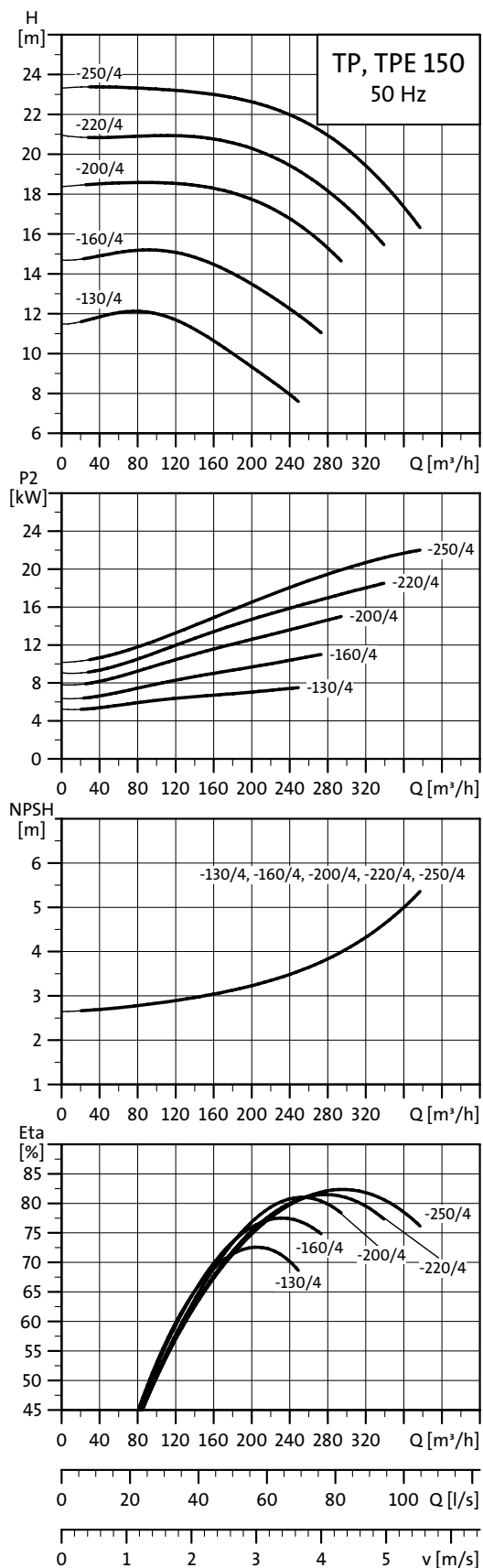

TM02 8754 0904

**Note:** All curves apply to single-head pumps. For further information, see page 49.

# Technical data

DN 150  
4-pole, PN 6, 10, 16

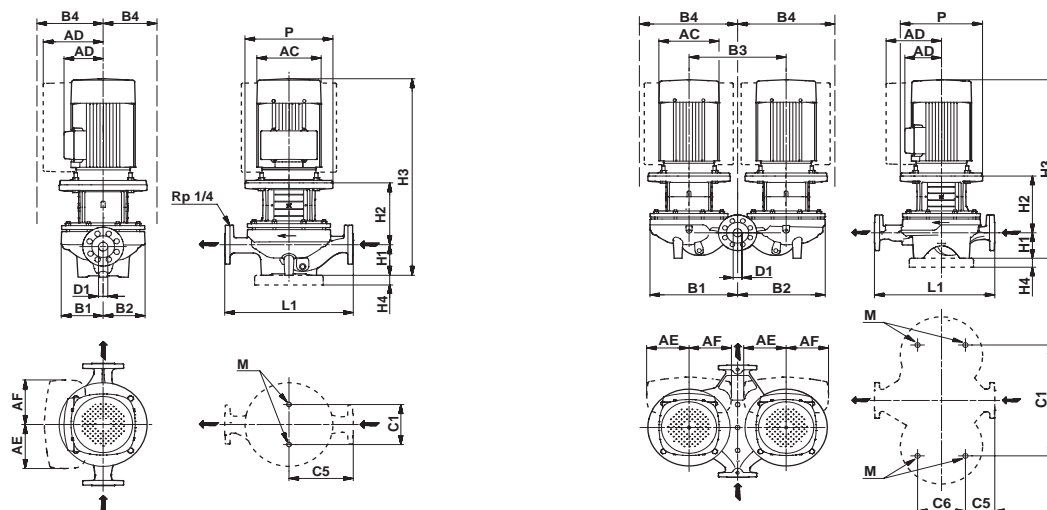

TM03 5348 3406 - TM03 5349 3406

## Technical data

TP 150		-130/4	-160/4	-200/4	-220/4	-250/4
TPD		●	●	●	●	●
TPE		●	●	●	●	-
TPED		●	●	●	●	-
Series		300	300	300	300	300
IEC size	1-phase TP	-	-	-	-	-
	3-phase TP	132	160	160	180	180
	1-phase TPE	-	-	-	-	-
	3-phase TPE	132	160	160	180	-
P2	1-/3-phase TP* [kW]	-/7.5	-/11	-/15	-/18.5	-/22
	1-/3-phase TPE [kW]	-/7.5	-/11	-/15	-/18.5	-
PN		PN 16	PN 16	PN 16	PN 16	PN 16
T <sub>min</sub> ; T <sub>max</sub>	[°C]	[-25;120]	[-25;120]	[-25;120]	[-25;120]	[-25;120]
D1	[mm]	150	150	150	150	150
AC	1-/3-phase TP [mm]	-/267	-/314	-/314	-/363	-/363
	1-/3-phase TPE [mm]	-/260	-/314	-/314	-/314	-
AD	1-/3-phase TP [mm]	-/167	-/204	-/204	-/258	-/258
	1-/3-phase TPE [mm]	-/213	-/308	-/308	-/308	-
AE	1-/3-phase TPE [mm]	145	210	210	210	-
AF	1-/3-phase TPE [mm]	145	210	210	210	-
P	[mm]	300	350	350	350	350
B1**	[mm]	296/583	296/583	296/583	296/583	296/583
B2**	[mm]	237/553	237/553	237/553	237/553	237/553
B3	[mm]	600	600	600	600	600
	TP [mm]	296/583	296/583	296/583	296/583	296/583
B4**	1-phase TPE [mm]	-	-	-	-	-
	3-phase TPE [mm]	296/583	308/583	308/583	308/583	-
C1**	[mm]	230/680	230/680	230/680	230/680	230/680
C5**	[mm]	400/153	400/153	400/153	400/153	400/153
C6	[mm]	350	350	350	350	350
L1	[mm]	800	800	800	800	800
H1	[mm]	215	215	215	215	215
H2	[mm]	291	321	321	321	321
H3	1-/3-phase TP [mm]	-/917	-/1008	-/1052	-/1139	-/1139
	1-/3-phase TPE [mm]	-/966	-/1008	-/1052	-/1078	-/-
H4	[mm]	-	35	35	35	35
M		M16	M16	M16	M16	M16

\* 2- and 4-pole TP and TPD pumps from 1.1 to 90 kW are fitted with motors as standard.

\*\* The dimension before the slash applies to the single-head pump, and the dimension after the slash applies to the twin-head pump.

# Performance curves

DN 150  
4-pole, PN 6, 10, 16

## TP, TPD, TPE, TPED 150-XXX/4

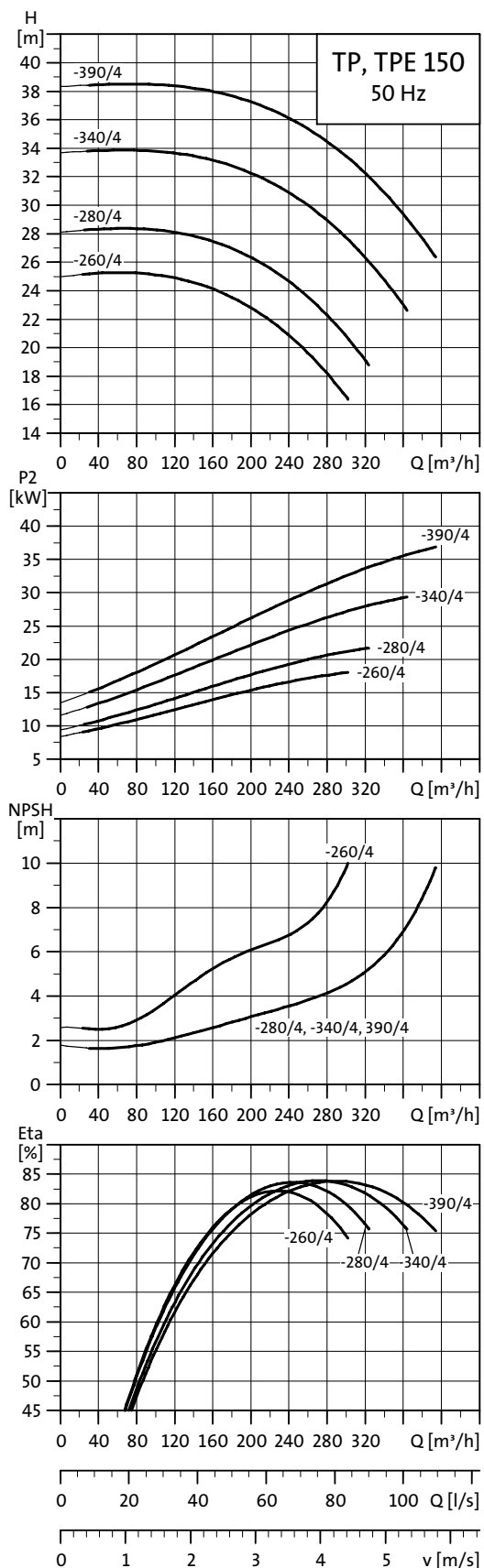

TM03 4548 2406

**Note:** All curves apply to single-head pumps. For further information, see page 49.

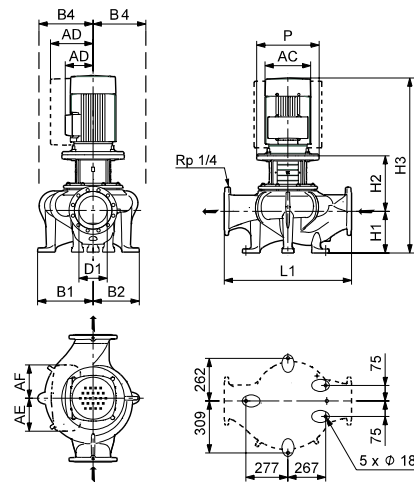

TM03 8623 4008

## Technical data

TP 150	-260/4	-280/4	-340/4	-390/4
TPD	-	-	-	-
TPE	●	-	-	-
TPED	-	-	-	-
Series	300	300	300	300
IEC size	1-phase TP	-	-	-
	3-phase TP	180	180	200
	1-phase TPE	-	-	-
	3-phase TPE	180	-	-
P2	1-/3-phase TP* [kW]	-/18.5	-/22	-/30
	1-/3-phase TPE [kW]	-/18.5	-/-	-/-
PN	PN 16	PN 16	PN 16	PN 16
T <sub>min</sub> ; T <sub>max</sub>	[°C]	[-25;120]	[-25;120]	[-25;120]
D1	[mm]	150	150	150
AC	1-/3-phase TP [mm]	-/363	-/363	-/402
	1-/3-phase TPE [mm]	-/314	-/-	-/-
AD	1-/3-phase TP [mm]	-/258	-/258	-/305
	1-/3-phase TPE [mm]	-/308	-/-	-/-
AE	1-/3-phase TPE [mm]	210	-	-
AF	1-/3-phase TPE [mm]	210	-	-
P	[mm]	350	350	400
B1**	[mm]	335/-	335/-	335/-
B2**	[mm]	288/-	288/-	288/-
B4**	TP [mm]	335/-	335/-	335/-
	1-phase TPE [mm]	-	-	-
	3-phase TPE [mm]	335/-	-/-	-/-
L1	[mm]	800	800	800
H1	[mm]	235	235	235
H2	[mm]	319	319	319
H3	1-/3-phase TP [mm]	-/1156	-/1156	-/1212
	1-/3-phase TPE [mm]	-/1095	-/-	-/-

\* 2- and 4-pole TP and TPD pumps from 1.1 to 90 kW are fitted with **EFFI** motors as standard.

\*\* The dimension before the slash applies to the single-head pump, and the dimension after the slash applies to the twin-head pump.

## TP 200-XXX/4

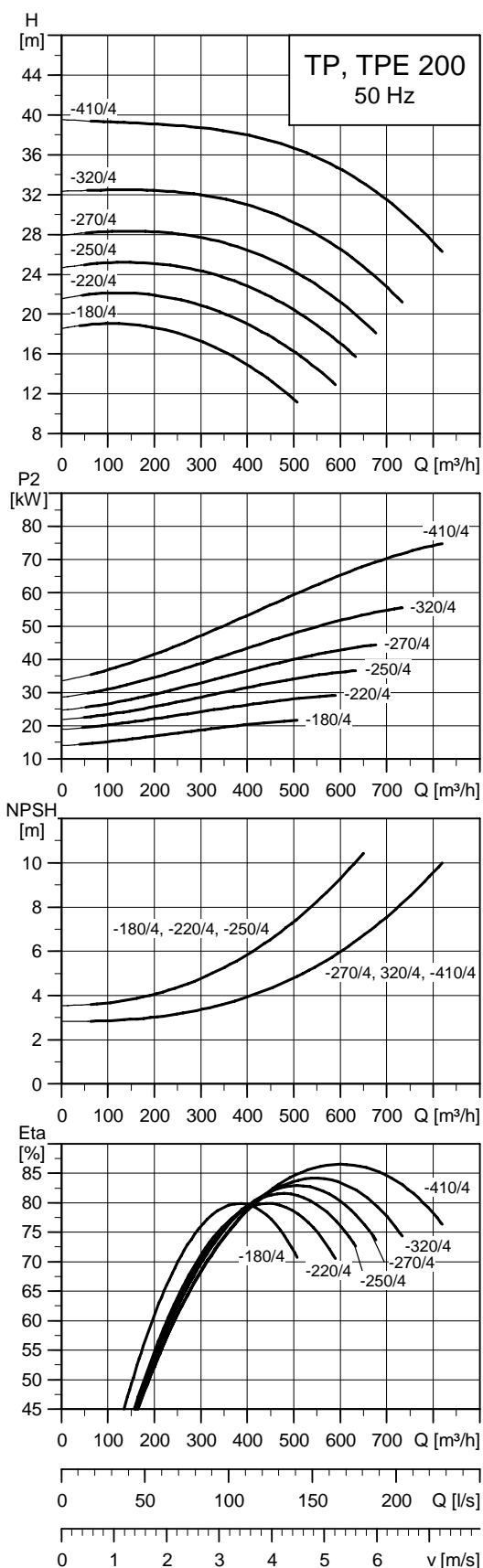

TM03 4650 2406

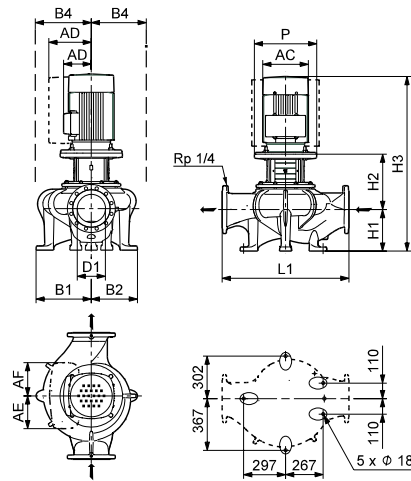

TM03 8621 4008

## Technical data

TP 200		-180/4	-220/4	-250/4	-270/4	-320/4	-410/4
TPD		-	-	-	-	-	-
TPE		-	-	-	-	-	-
TPED		-	-	-	-	-	-
Series		300	300	300	300	300	300
IEC size	1-phase TP	-	-	-	-	-	-
	3-phase TP	180	200	225	225	250	280
	1-phase TPE	-	-	-	-	-	-
	3-phase TPE	-	-	-	-	-	-
P2	1-/3-phase TP* [kW]	-/22	-/30	-/37	-/45	-/55	-/75
	1-/3-phase TPE [kW]	-/-	-/-	-/-	-/-	-/-	-/-
PN		PN 16	PN 16	PN 16	PN 16	PN 16	PN 16
T <sub>min</sub> ; T <sub>max</sub>	[°C]	[-25;120]	[-25;120]	[-25;120]	[-25;120]	[-25;120]	[-25;120]
D1	[mm]	200	200	200	200	200	200
AC	1-/3-phase TP [mm]	-/363	-/402	-/442	-/442	-/495	-/555
	1-/3-phase TPE [mm]	-/-	-/-	-/-	-/-	-/-	-/-
AD	1-/3-phase TP [mm]	-/258	-/305	-/325	-/325	-/392	-/432
	1-/3-phase TPE [mm]	-/-	-/-	-/-	-/-	-/-	-/-
AE	1-/3-phase TPE [mm]	-	-	-	-	-	-
AF	1-/3-phase TPE [mm]	-	-	-	-	-	-
P	[mm]	350	400	450	450	550	550
B1**	[mm]	393/-	393/-	393/-	393/-	393/-	393/-
B2**	[mm]	328/-	328/-	328/-	328/-	328/-	328/-
B4**	TP [mm]	393/-	393/-	393/-	393/-	393/-	432/-
	1-phase TPE [mm]	-	-	-	-	-	-
	3-phase TPE [mm]	-/-	-/-	-/-	-/-	-/-	-/-
L1	[mm]	900	900	900	900	900	900
H1	[mm]	295	295	295	295	295	295
H2	[mm]	347	347	377	377	377	377
H3	1-/3-phase TP [mm]	-/1244	-/1300	-/1321	-/1381	-/1489	-/1492
	1-/3-phase TPE [mm]	-/-	-/-	-/-	-/-	-/-	-/-

\* 2- and 4-pole TP and TPD pumps from 1.1 to 90 kW are fitted with **EFF1** motors as standard.

\*\* The dimension before the slash applies to the single-head pump, and the dimension after the slash applies to the twin-head pump.

## TP 200-XXX/4

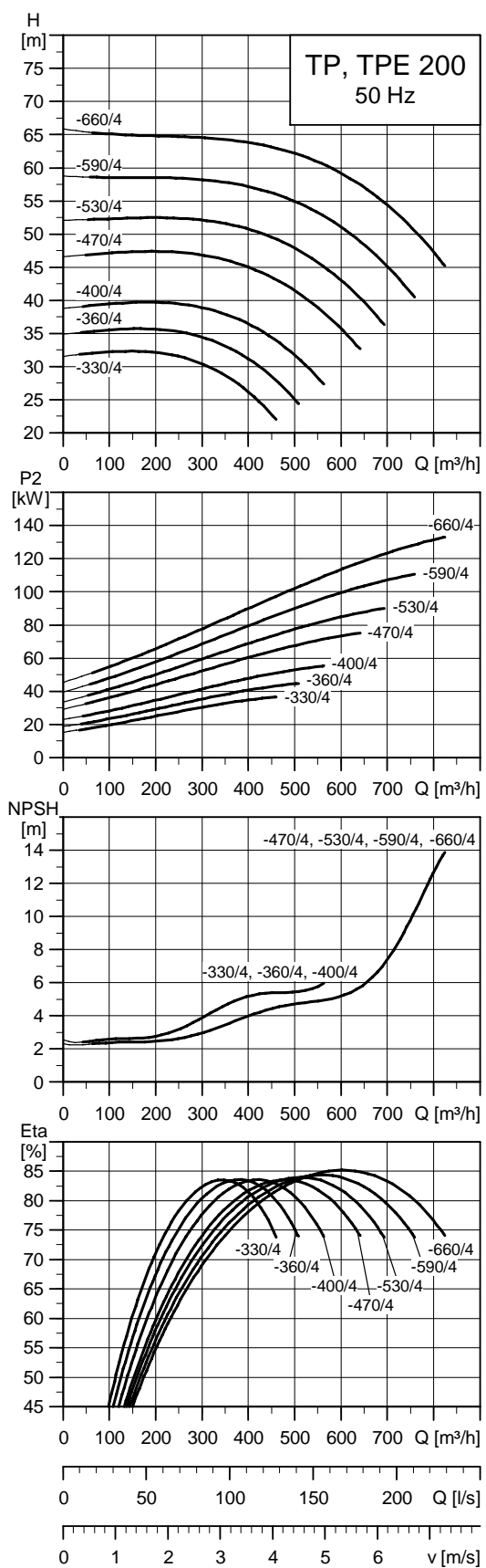

TM03 4651 2007

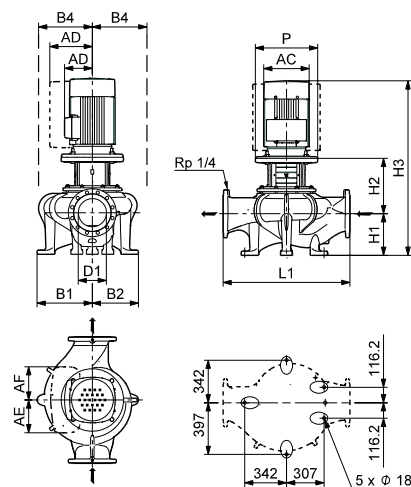

TMD03 8622 4008

## Technical data

TP 200		-330/4	-360/4	-400/4	-470/4	-530/4	-590/4	-660/4
TPD		-	-	-	-	-	-	-
TPE		-	-	-	-	-	-	-
TPED		-	-	-	-	-	-	-
Series		300	300	300	300	300	300	300
IEC size	1-phase TP	-	-	-	-	-	-	-
	3-phase TP	225	225	250	280	280	315	315
	1-phase TPE	-	-	-	-	-	-	-
	3-phase TPE	-	-	-	-	-	-	-
P2	1-/3-phase TP* [kW]	-/37	-/45	-/55	-/75	-/90	-/110	-/132
	1-/3-phase TPE [kW]	-/-	-/-	-/-	-/-	-/-	-/-	-/-
PN		PN 16	PN 16	PN 16	PN 16	PN 16	PN 16	PN 16
T <sub>min</sub> ; T <sub>max</sub>	[°C]	[-25;120]	[-25;120]	[-25;120]	[-25;120]	[-25;120]	[-25;120]	[-25;120]
D1	[mm]	200	200	200	200	200	200	200
AC	1-/3-phase TP [mm]	-/442	-/442	-/495	-/555	-/555	-/610	-/610
	1-/3-phase TPE [mm]	-/-	-/-	-/-	-/-	-/-	-/-	-/-
AD	1-/3-phase TP [mm]	-/325	-/325	-/392	-/432	-/432	-/495	-/495
	1-/3-phase TPE [mm]	-/-	-/-	-/-	-/-	-/-	-/-	-/-
AE	1-/3-phase TPE [mm]	-	-	-	-	-	-	-
AF	1-/3-phase TPE [mm]	-	-	-	-	-	-	-
P	[mm]	450	450	550	550	550	660	660
B1**	[mm]	423/-	423/-	423/-	423/-	423/-	423/-	423/-
B2**	[mm]	368/-	368/-	368/-	368/-	368/-	368/-	368/-
B4**	TP [mm]	423/-	423/-	423/-	432/-	432/-	495/-	495/-
	1-phase TPE [mm]	-	-	-	-	-	-	-
	3-phase TPE [mm]	-/-	-/-	-/-	-/-	-/-	-/-	-/-
L1	[mm]	1000	1000	1000	1000	1000	1000	1000
H1	[mm]	295	295	295	295	295	295	295
H2	[mm]	382	382	382	382	382	412	412
H3	1-/3-phase TP [mm]	-/1326	-/1386	-/1494	-/1497	-/1607	-/1639	-/1799
	1-/3-phase TPE [mm]	-/-	-/-	-/-	-/-	-/-	-/-	-/-

★ 2- and 4-pole TP and TPD pumps from 1.1 to 90 kW are fitted with  motors as standard.

★★ The dimension before the slash applies to the single-head pump, and the dimension after the slash applies to the twin-head pump.

# Performance curves

DN 250  
4-pole, PN 10

## TP 250-XXX/4

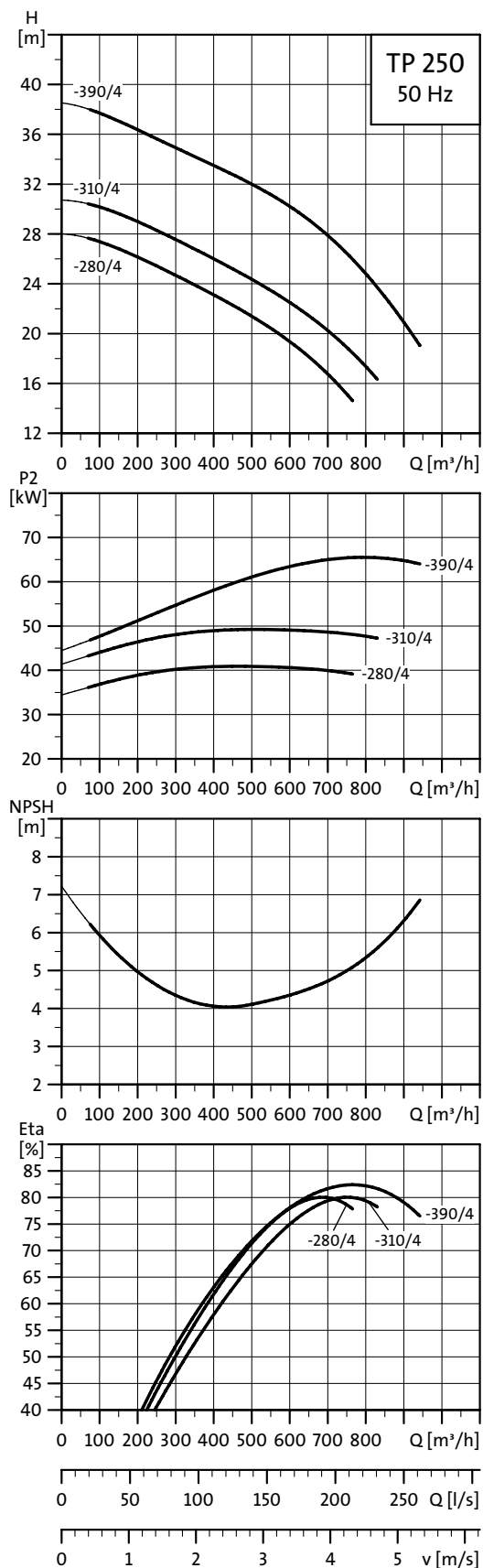

TM02 6816 0504

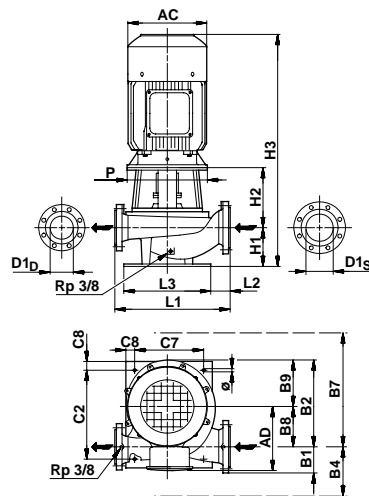

TM02 8349 5004

## Technical data

TP 250		-280/4	-310/4	-390/4
TPD		-	-	-
TPE		-	-	-
TPED		-	-	-
Series		400	400	400
IEC size	1-phase TP	-	-	-
	3-phase TP	225 M	250 M	280 S
	1-phase TPE	-	-	-
	3-phase TPE	-	-	-
P2*	[kW]	45	55	75
PN		10	10	10
T <sub>min</sub> ; T <sub>max</sub>	[°C]	[-25;120]	[-25;120]	[-25;120]
D1 <sub>D</sub> /D1 <sub>S</sub>	[mm]	250/300	250/300	250/300
AC	[mm]	442	495	555
AD	[mm]	325	392	432
P	[mm]	550	550	550
B1	[mm]	223	223	223
B2	[mm]	635	635	635
B4	[mm]	223	223	223
B7	[mm]	647	647	647
B8	[mm]	300	300	300
B9	[mm]	335	335	335
C2	[mm]	580	580	580
C7	[mm]	520	520	520
C8	[mm]	50	50	50
∅	[mm]	20	20	20
L1	[mm]	950	950	950
L2	[mm]	190	190	190
L3	[mm]	620	620	620
H1	[mm]	310	310	310
H2	[mm]	368	368	368
H3	[mm]	1387	1495	1498

\* 2- and 4-pole TP and TPD pumps from 1.1 to 90 kW are fitted with  motors as standard.

## TP, TPD, TPE, TPED, 6-pole, PN 16

### TP, TPD 125-XXX/6

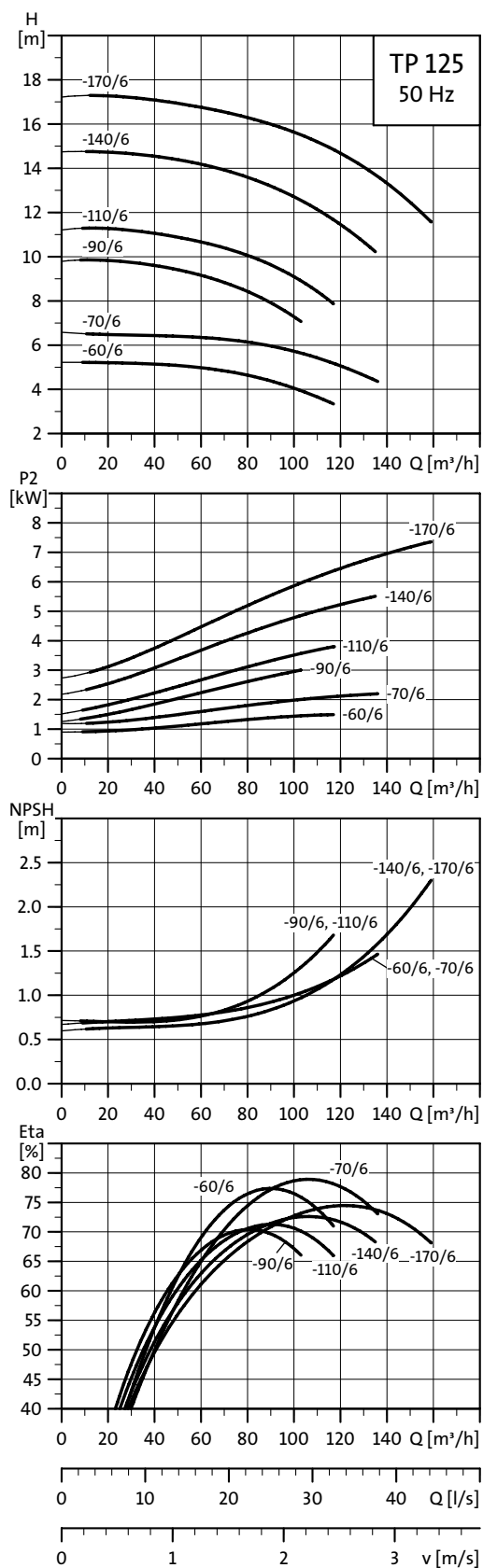

TM02 8757 0904

**Note:** All curves apply to single-head pumps. For further information, see page 49.

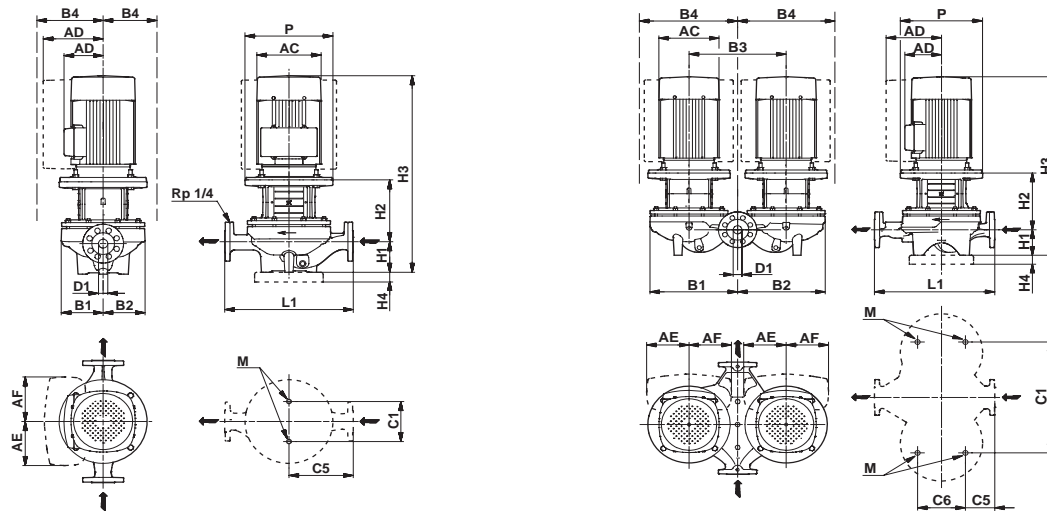

TM03 5348 3406 - TM03 5349 3406

## Technical data

TP 125		-60/6	-70/6	-90/6	-110/6	-140/6	-170/6
TPD		●	●	●	●	●	●
TPE		-	-	-	-	-	-
TPED		-	-	-	-	-	-
Series		300	300	300	300	300	300
IEC size	1-phase TP	-	-	-	-	-	-
	3-phase TP	100	112	132	132	132	160
	1-phase TPE	-	-	-	-	-	-
	3-phase TPE	-	-	-	-	-	-
P2	1-/3-phase TP [kW]	-/1.5	-/2.2	-/3	-/4	-/5.5	-/7.5
	1-/3-phase TPE [kW]	-/-	-/-	-/-	-/-	-/-	-/-
PN		PN 16	PN 16	PN 16	PN 16	PN 16	PN 16
T <sub>min</sub> ; T <sub>max</sub>	[°C]	[-25;120]	[-25;120]	[-25;120]	[-25;120]	[-25;120]	[-25;120]
D1	[mm]	125	125	125	125	125	125
AC	1-/3-phase TP [mm]	-/203	-/227	-/267	-/267	-/267	-/320
	1-/3-phase TPE [mm]	-/-	-/-	-/-	-/-	-/-	-/-
AD	1-/3-phase TP [mm]	-/135	-/148	-/167	-/167	-/167	-/197
	1-/3-phase TPE [mm]	-/-	-/-	-/-	-/-	-/-	-/-
AE	1-/3-phase TPE [mm]	-	-	-	-	-	-
AF	1-/3-phase TPE [mm]	-	-	-	-	-	-
P	[mm]	250	250	300	300	300	350
B1**	[mm]	250/537	250/537	271/566	271/566	271/566	271/566
B2**	[mm]	202/518	202/518	243/552	243/552	243/552	243/552
B3	[mm]	600	600	600	600	600	600
	TP [mm]	250/537	250/537	271/566	271/566	271/566	271/566
B4**	1-phase TPE [mm]	-	-	-	-	-	-
	3-phase TPE [mm]	-	-	-	-	-	-
C1**	[mm]	230/680	230/680	230/680	230/680	230/680	230/680
C5**	[mm]	310/84	310/84	400/175	400/175	400/175	400/175
C6	[mm]	300	300	350	350	350	350
L1	[mm]	620	620	800	800	800	800
H1	[mm]	215	215	215	215	215	215
H2	[mm]	267	267	288	288	288	318
H3	1-/3-phase TP [mm]	-/829	-/853	-/876	-/914	-/914	-/1011
	[mm]	-/-	-/-	-/-	-/-	-/-	-/-
H4	[mm]	-	-	-	-	-	-
M		M16	M16	M16	M16	M16	M16

\*\* The dimension before the slash applies to the single-head pump, and the dimension after the slash applies to the twin-head pump.

## TP, TPD 150-XXX/6

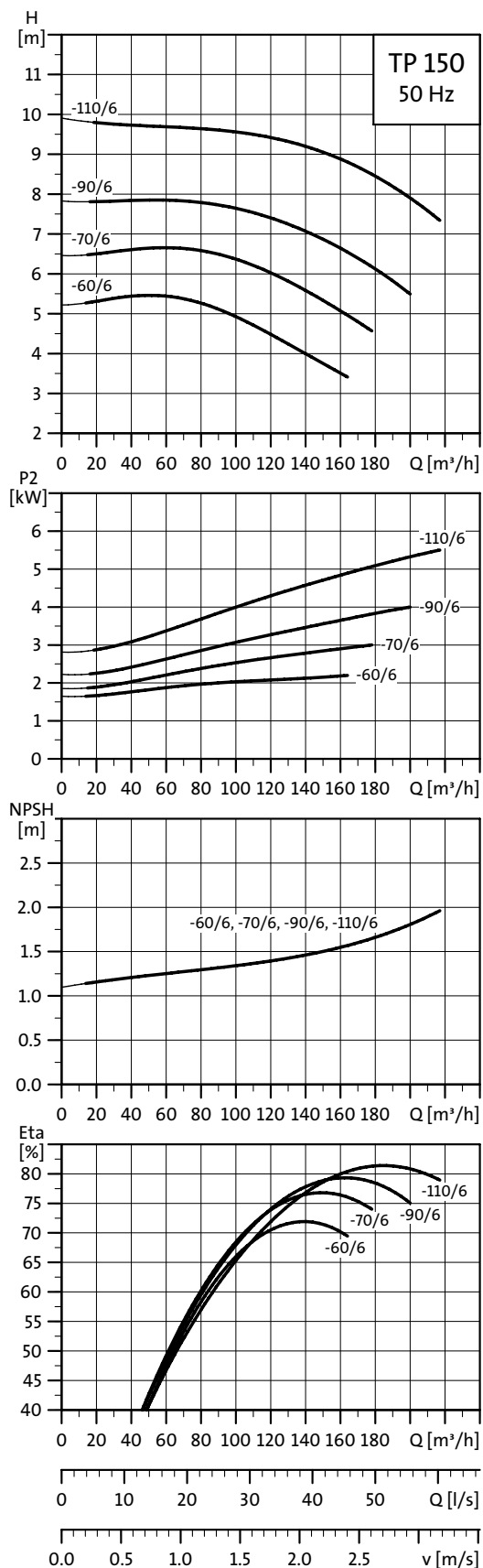

TM02 8758 0904

**Note:** All curves apply to single-head pumps. For further information, see page 49.

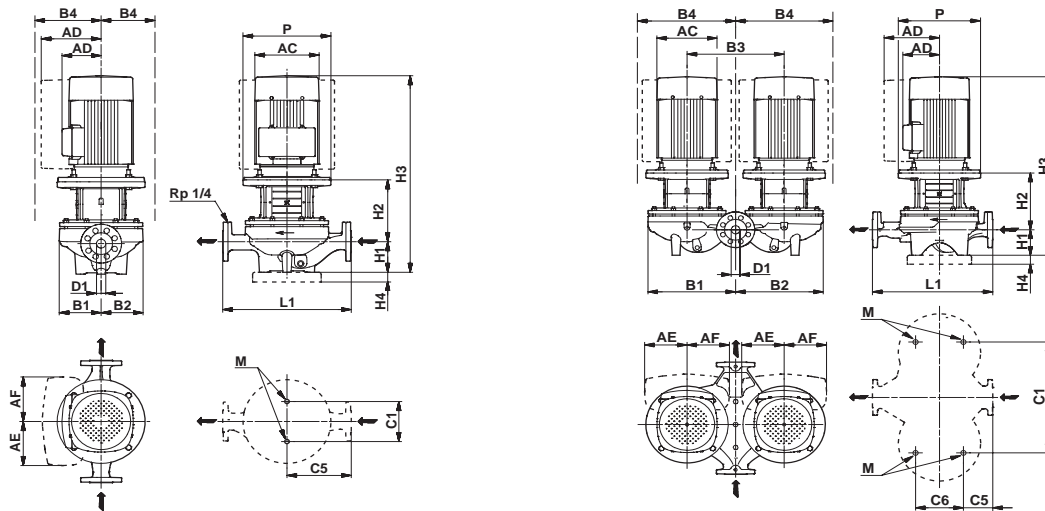

TM03 5348 3406 - TM03 5349 3406

## Technical data

TP 150		-60/6	-70/6	-90/6	-110/6
TPD		●	●	●	●
TPE		-	-	-	-
TPED		-	-	-	-
Series		300	300	300	300
IEC size	1-phase TP	-	-	-	-
	3-phase TP	112	132	132	132
	1-phase TPE	-	-	-	-
	3-phase TPE	-	-	-	-
P2	1-/3-phase TP [kW]	-/2.2	-/3	-/4	-/5.5
	1-/3-phase TPE [kW]	-/-	-/-	-/-	-/-
PN		PN 16	PN 16	PN 16	PN 16
T <sub>min</sub> ; T <sub>max</sub>	[°C]	[-25;120]	[-25;120]	[-25;120]	[-25;120]
D1	[mm]	150	150	150	150
AC	1-/3-phase TP [mm]	-/227	-/267	-/267	-/267
	1-/3-phase TPE [mm]	-/-	-/-	-/-	-/-
AD	1-/3-phase TP [mm]	-/148	-/167	-/167	-/167
	1-/3-phase TPE [mm]	-/-	-/-	-/-	-/-
AE	1-/3-phase TPE [mm]	-	-	-	-
AF	1-/3-phase TPE [mm]	-	-	-	-
P	[mm]	250	300	300	300
B1**	[mm]	296/583	296/583	296/583	296/583
B2**	[mm]	237/553	237/553	237/553	237/553
B3	[mm]	600	600	600	600
	TP [mm]	296/583	296/583	296/583	296/583
	1-phase TPE [mm]	-	-	-	-
B4**	3-phase TPE [mm]	-	-	-	-
	[mm]	230/680	230/680	230/680	230/680
C1**	[mm]	400/153	400/153	400/153	400/153
C5**	[mm]	350	350	350	350
L1	[mm]	800	800	800	800
H1	[mm]	215	215	215	215
H2	[mm]	275	291	291	291
H3	1-/3-phase TP [mm]	-/862	-/879	-/917	-/917
	1-/3-phase TPE [mm]	-/-	-/-	-/-	-/-
H4	[mm]	-	-	-	-
M		M16	M16	M16	M16

\*\* The dimension before the slash applies to the single-head pump, and the dimension after the slash applies to the twin-head pump.

# Performance curves

DN 100  
2-pole, PN 25

TP, 2-pole, PN 25

TP 100-XXX/2

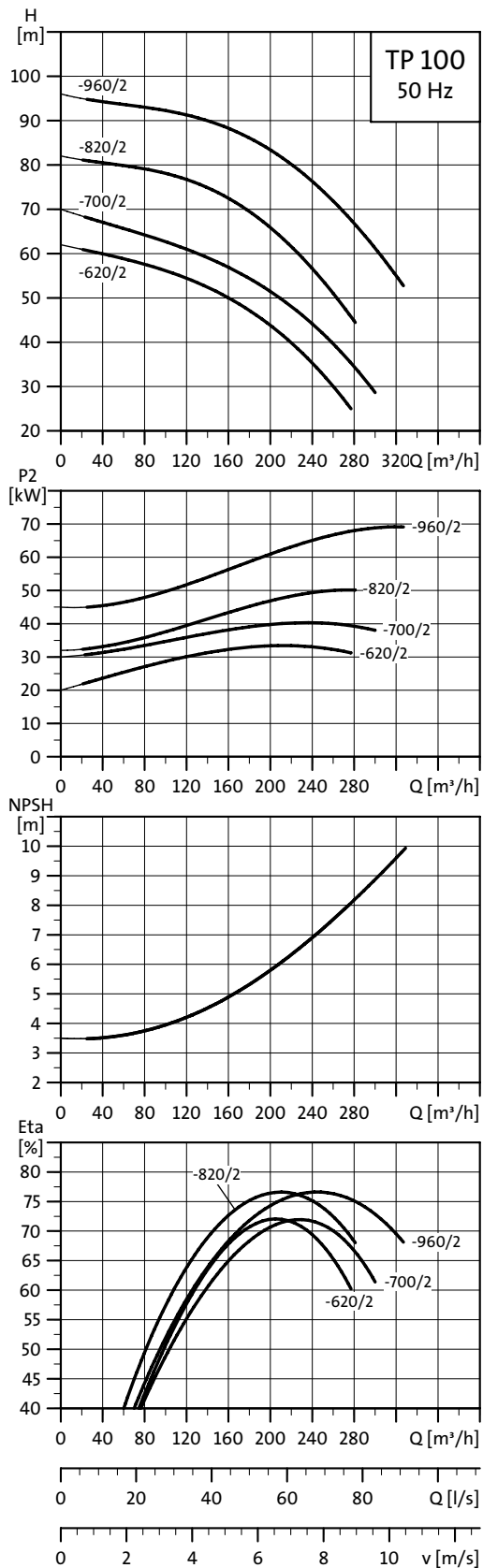

TM02 6830 0504

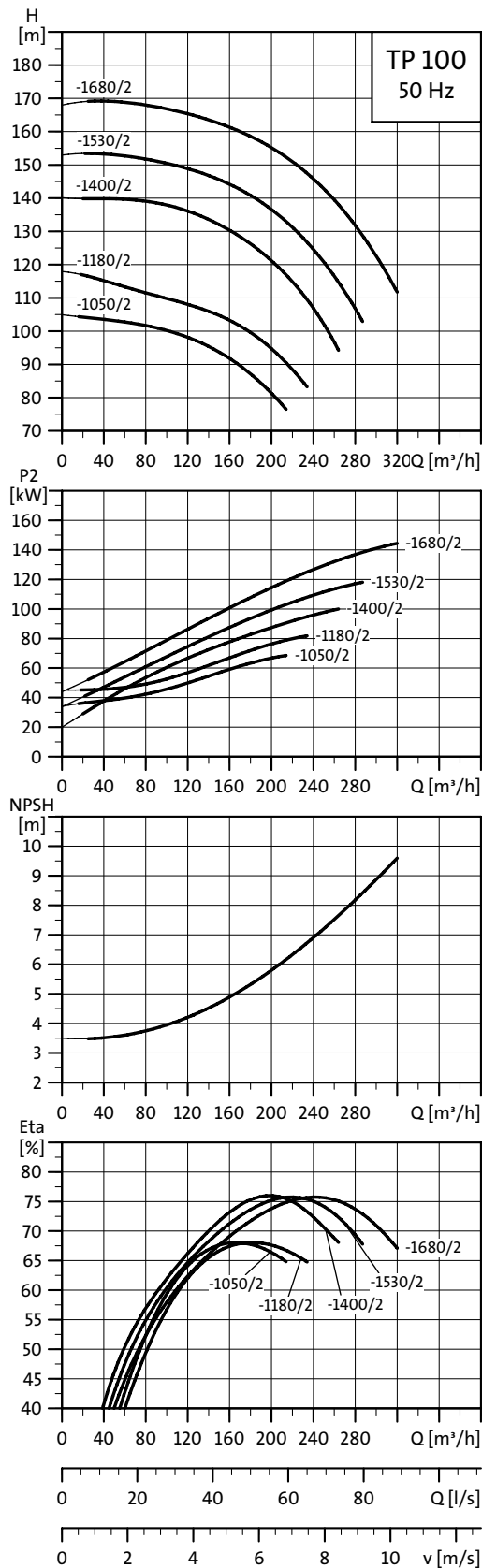

TTM02 6831 0504

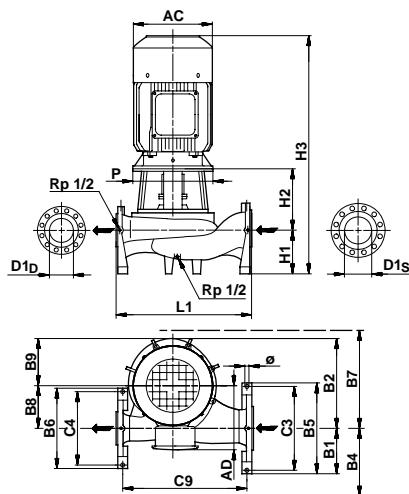

TM02 8350 5004

## Technical data

TP 100		-620/2	-700/2	-820/2	-960/2	-1050/2	-1180/2	-1400/2	-1530/2	-1680/2
TPD		-	-	-	-	-	-	-	-	-
TPE		-	-	-	-	-	-	-	-	-
TPED		-	-	-	-	-	-	-	-	-
Series		400	400	400	400	400	400	400	400	400
IEC size	1-phase TP	-	-	-	-	-	-	-	-	-
	3-phase TP	200 L	225 M	250 M	280 S	280 S	280 M	315 S	315 M	315 L
	1-phase TPE	-	-	-	-	-	-	-	-	-
	3-phase TPE	-	-	-	-	-	-	-	-	-
P2*	[kW]	37	45	55	75	75	90	110	132	160
PN		25	25	25	25	25	25	25	25	25
T <sub>min</sub> ; T <sub>max</sub>	[°C]	[0;150]	[0;150]	[0;150]	[0;150]	[0;150]	[0;150]	[0;150]	[0;150]	[0;150]
D1 <sub>D</sub> /D1 <sub>S</sub>	[mm]	100/125	100/125	100/125	100/125	100/125	100/125	100/125	100/125	100/125
AC	[mm]	402	442	495	555	555	555	610	610	610
AD	[mm]	305	325	392	432	432	432	495	495	495
P	[mm]	550	550	550	550	550	550	800	800	800
B1	[mm]	180	180	180	180	180	180	180	180	180
B2	[mm]	407	407	407	407	425	425	425	425	425
B4	[mm]	180	180	193	227	219	219	312	312	312
B5	[mm]	360	360	360	360	360	360	360	360	360
B6	[mm]	335	335	335	335	335	335	335	335	335
B7	[mm]	467	467	467	467	475	475	600	600	600
B8	[mm]	192	192	192	192	200	200	200	200	200
B9	[mm]	215	215	215	215	225	225	225	225	225
C3	[mm]	320	320	320	320	320	320	320	320	320
C4	[mm]	295	295	295	295	295	295	295	295	295
C9	[mm]	489	489	489	489	606	606	606	606	606
∅	[mm]	20	20	20	20	20	20	20	20	20
L1	[mm]	543	543	543	543	660	660	660	660	660
H1	[mm]	160	160	160	160	170	170	170	170	170
H2	[mm]	315	315	315	315	300	300	303	303	303
H3	[mm]	1133	1184	1222	1295	1290	1400	1405	1565	1565

\* 2- and 4-pole TP and TPD pumps from 1.1 to 90 kW are fitted with  motors as standard.

# Performance curves

DN 100  
4-pole, PN 25

## TP, 4-pole, PN 25

### TP 100-XXX/4

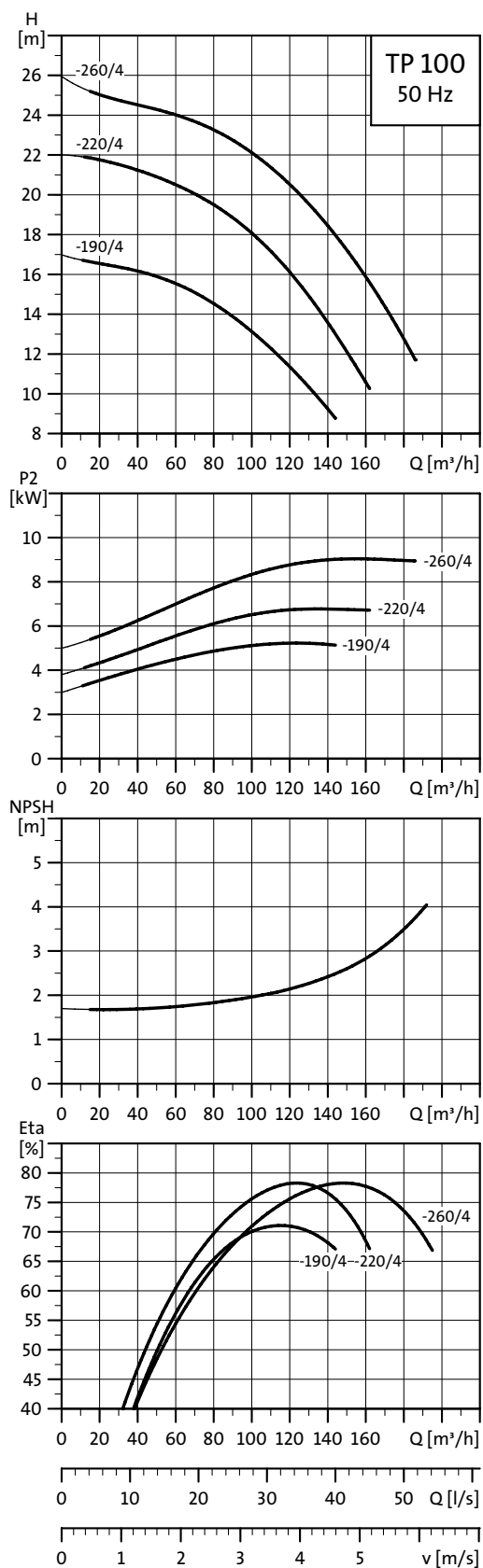

TM02 6837 0504

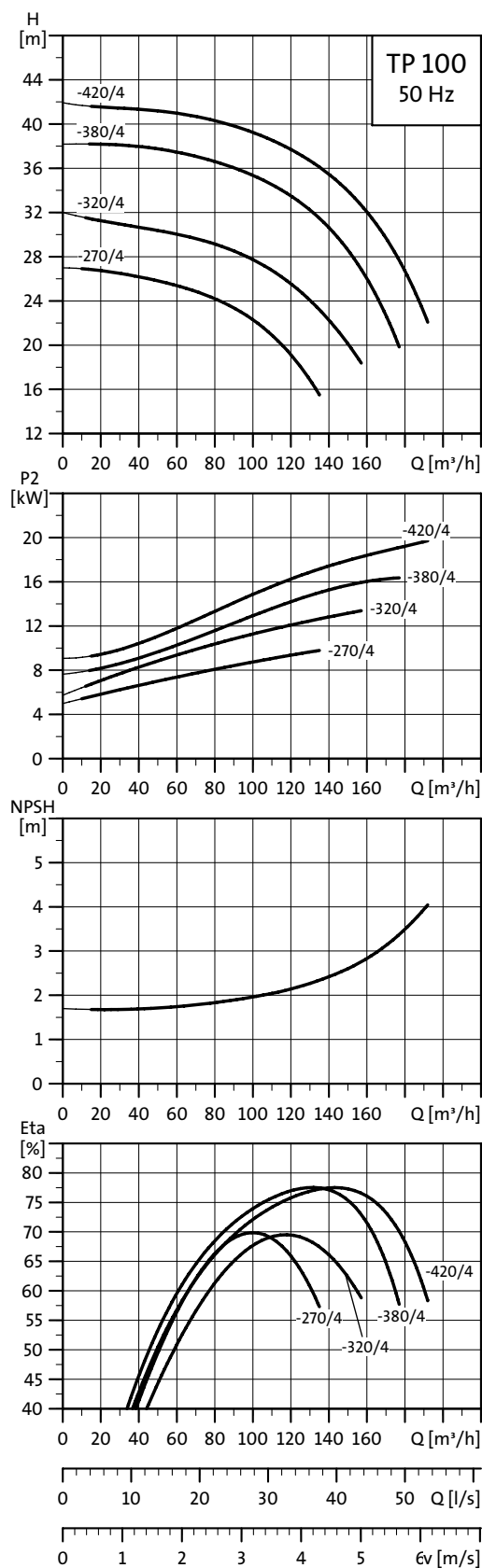

TM02 6838 0504

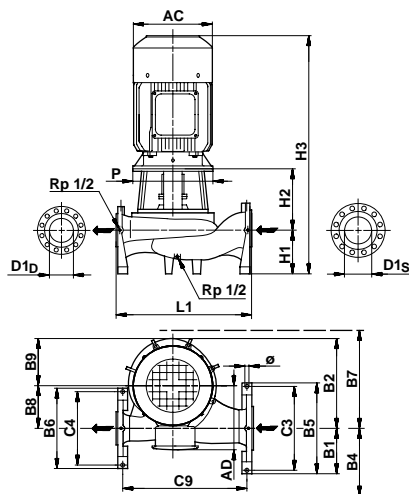

TM02 8350 5004

## Technical data

TP 100	-190/4	-220/4	-260/4	-270/4	-320/4	-380/4	-420/4
TPD	-	-	-	-	-	-	-
TPE	-	-	-	-	-	-	-
TPED	-	-	-	-	-	-	-
Series	400	400	400	400	400	400	400
IEC size	1-phase TP	-	-	-	-	-	-
	3-phase TP	132 S	132 M	160 M	160 M	160 L	180 M
	1-phase TPE	-	-	-	-	-	-
	3-phase TPE	-	-	-	-	-	-
P2*	[kW]	5.5	7.5	11	11	15	18.5
PN		25	25	25	25	25	25
T <sub>min</sub> ; T <sub>max</sub>	[°C]	[0;150]	[0;150]	[0;150]	[0;150]	[0;150]	[0;150]
D1 <sub>D</sub> /D1 <sub>S</sub>	[mm]	100/125	100/125	100/125	100/125	100/125	100/125
AC	[mm]	260	260	314	314	314	363
AD	[mm]	159	159	204	204	204	258
P	[mm]	400	400	400	450	450	450
B1	[mm]	180	180	180	180	180	180
B2	[mm]	407	407	407	425	425	425
B4	[mm]	180	180	180	180	180	180
B5	[mm]	360	360	360	360	360	360
B6	[mm]	335	335	335	335	335	335
B7	[mm]	401	401	401	429	430	429
B8	[mm]	192	192	192	200	200	200
B9	[mm]	215	215	215	225	225	225
C3	[mm]	320	320	320	320	320	320
C4	[mm]	295	295	295	295	295	295
C9	[mm]	489	489	489	606	606	606
Ø	[mm]	20	20	20	20	20	20
L1	[mm]	543	543	543	660	660	660
H1	[mm]	160	160	160	170	170	170
H2	[mm]	285	285	285	270	270	270
H3	[mm]	824	874	916	911	955	1042

\* 2- and 4-pole TP and TPD pumps from 1.1 to 90 kW are fitted with **EFF I** motors as standard.

## TP 125-XXX/4

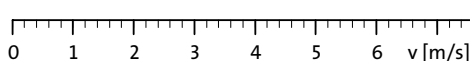
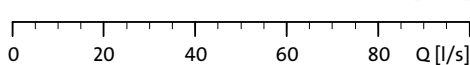
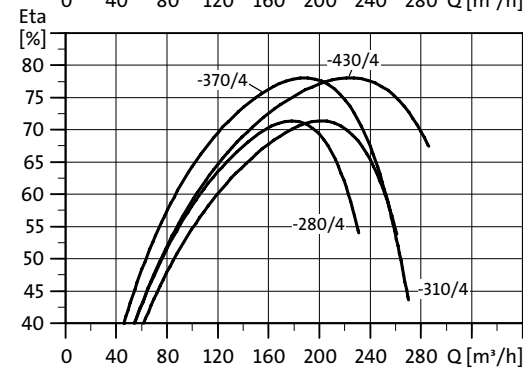
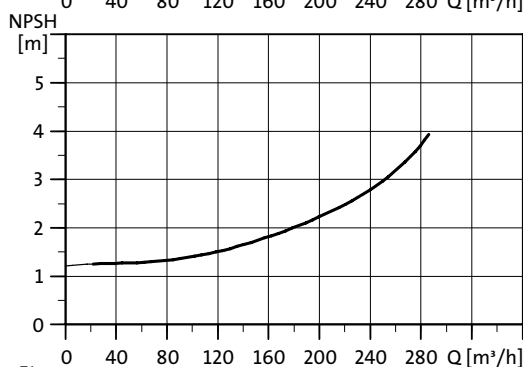
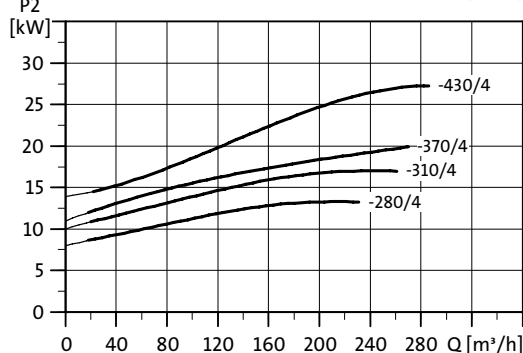
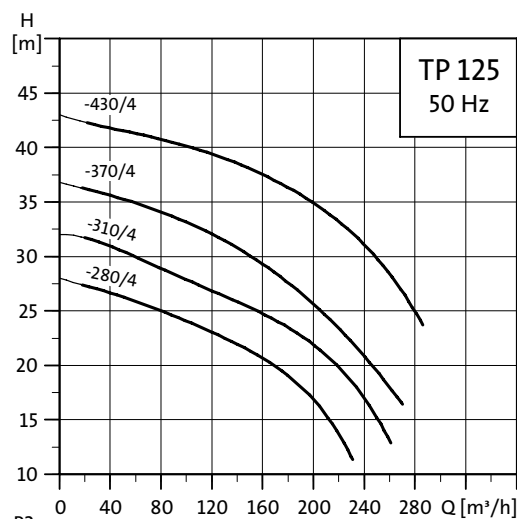
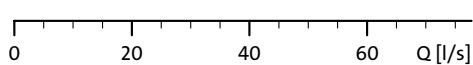
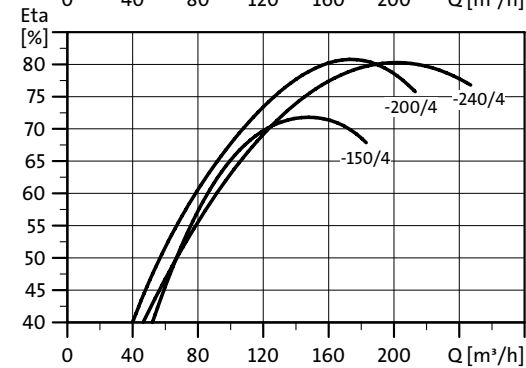
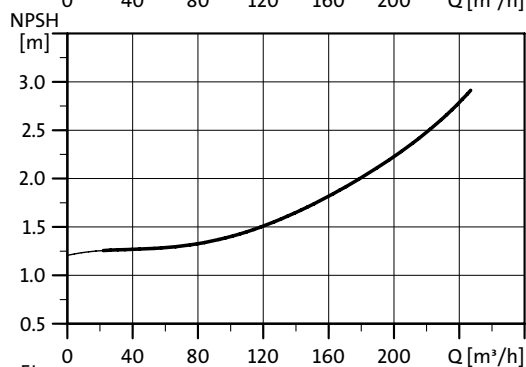
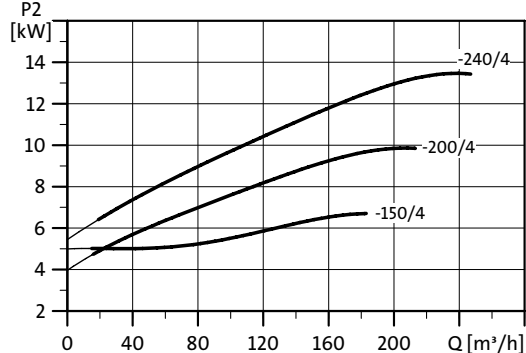
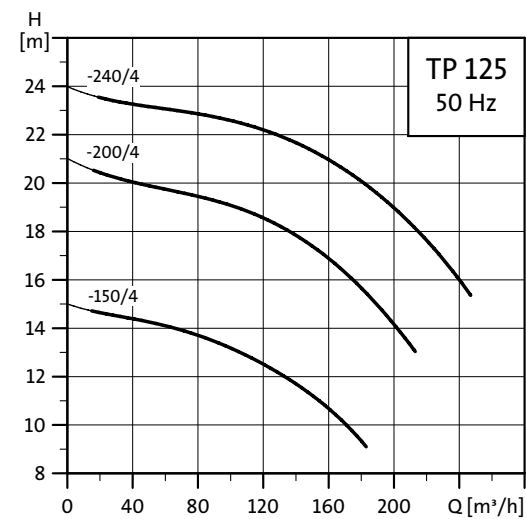

TM02 6839 0504

TM02 6840 0805

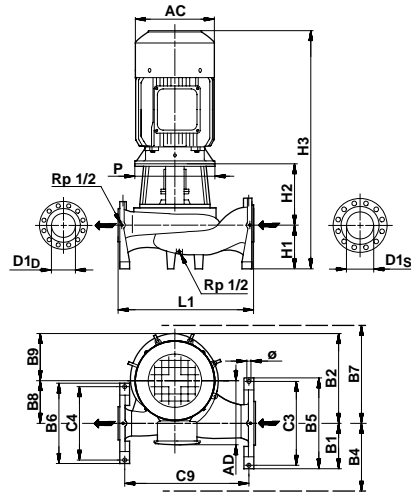

TM02 8350 5004

## Technical data

TP 125		-150/4	-200/4	-240/4	-280/4	-310/4	-370/4	-430/4
TPD		-	-	-	-	-	-	-
TPE		-	-	-	-	-	-	-
TPED		-	-	-	-	-	-	-
Series		400	400	400	400	400	400	400
IEC size	1-phase TP	-	-	-	-	-	-	-
	3-phase TP	132 M	160 M	160 L	160 L	180 M	180 L	200 L
	1-phase TPE	-	-	-	-	-	-	-
	3-phase TPE	-	-	-	-	-	-	-
P2*	[kW]	7.5	11	15	15	18.5	22	30
PN		25	25	25	25	25	25	25
T <sub>min</sub> ; T <sub>max</sub>	[°C]	[0;150]	[0;150]	[0;150]	[0;150]	[0;150]	[0;150]	[0;150]
D1 <sub>D</sub> /D1 <sub>S</sub>	[mm]	125/150	125/150	125/150	125/150	125/150	125/150	125/150
AC	[mm]	260	314	314	314	363	363	402
AD	[mm]	159	204	204	204	258	258	305
P	[mm]	400	400	400	450	450	450	450
B1	[mm]	200	200	200	200	200	200	200
B2	[mm]	430	430	430	451	451	451	451
B4	[mm]	200	200	200	200	200	200	200
B5	[mm]	400	400	400	400	400	400	400
B6	[mm]	360	360	360	360	360	360	360
B7	[mm]	423	423	423	467	468	468	467
B8	[mm]	200	200	200	224	224	224	224
B9	[mm]	230	230	230	227	227	227	227
C3	[mm]	360	360	360	360	360	360	360
C4	[mm]	320	320	320	320	320	320	320
C9	[mm]	536	536	536	606	606	606	606
Ø	[mm]	20	20	20	20	20	20	20
L1	[mm]	590	590	590	660	660	660	660
H1	[mm]	185	185	185	180	180	180	180
H2	[mm]	287	287	287	283	283	283	283
H3	[mm]	902	943	987	978	1065	1065	1121

\* 2- and 4-pole TP and TPD pumps from 1.1 to 90 kW are fitted with  motors as standard.

# Performance curves

DN 150  
4-pole, PN 25

## TP 150-XXX/4

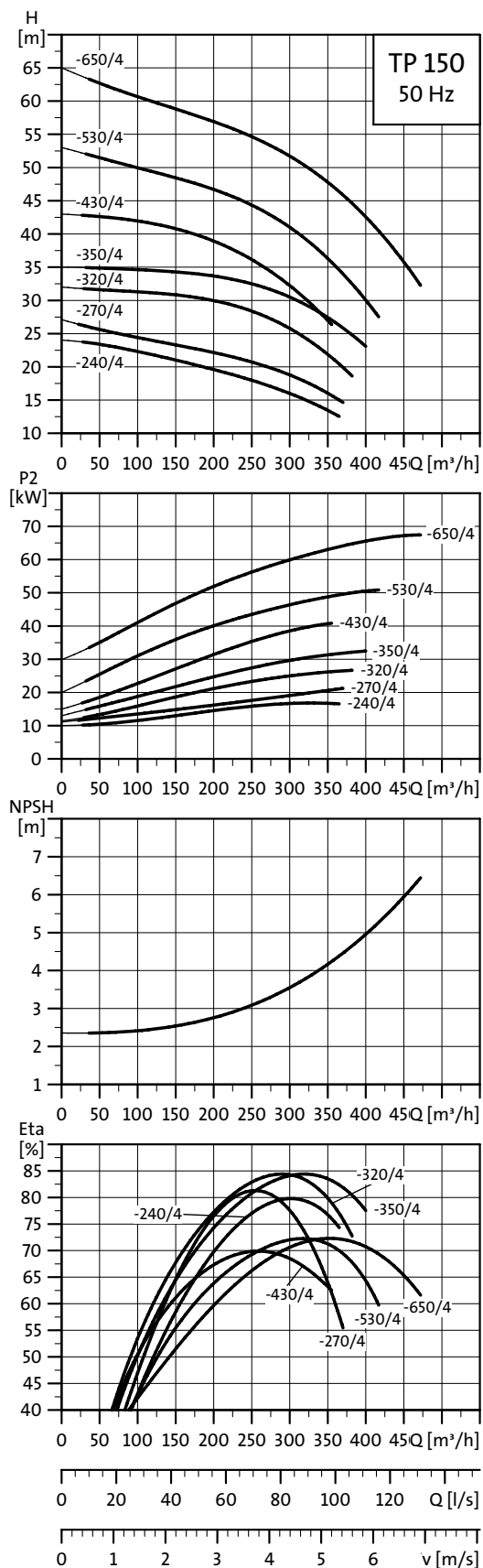

TM02 6842 0504

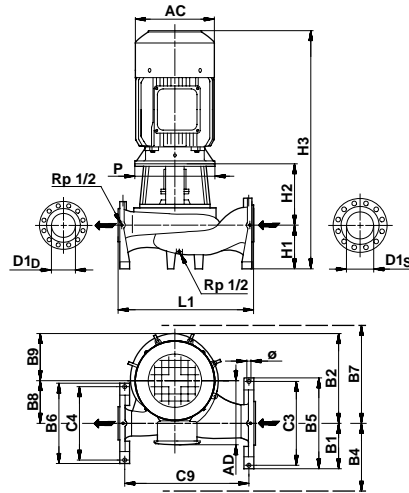

TM02 8350 5004

## Technical data

TP 150		-240/4	-270/4	-320/4	-350/4	-430/4	-530/4	-650/4
TPD		-	-	-	-	-	-	-
TPE		-	-	-	-	-	-	-
TPED		-	-	-	-	-	-	-
Series		400	400	400	400	400	400	400
IEC size	1-phase TP	-	-	-	-	-	-	-
	3-phase TP	180 M	180 L	200 L	225 S	225 M	250 M	280 S
	1-phase TPE	-	-	-	-	-	-	-
	3-phase TPE	-	-	-	-	-	-	-
P2*	[kW]	18.5	22	30	37	45	55	75
PN		25	25	25	25	25	25	25
T <sub>min</sub> ; T <sub>max</sub>	[°C]	[0;150]	[0;150]	[0;150]	[0;150]	[0;150]	[0;150]	[0;150]
D1 <sub>D</sub> /D1 <sub>S</sub>	[mm]	150/200	150/200	150/200	150/200	150/200	150/200	150/200
AC	[mm]	363	363	402	442	442	495	555
AD	[mm]	258	258	305	325	325	392	432
P	[mm]	450	450	450	550	550	550	550
B1	[mm]	230	230	230	230	235	235	235
B2	[mm]	504	504	504	504	575	575	575
B4	[mm]	230	230	230	230	235	235	235
B5	[mm]	460	460	460	460	470	470	470
B6	[mm]	400	400	400	400	410	410	410
B7	[mm]	517	517	518	518	584	584	584
B8	[mm]	229	229	229	229	260	260	260
B9	[mm]	275	275	275	275	315	315	315
C3	[mm]	420	420	420	420	420	420	420
C4	[mm]	360	360	360	360	360	360	360
C9	[mm]	676	676	676	676	823	823	823
Ø	[mm]	20	20	20	20	20	20	20
L1	[mm]	740	740	740	740	900	900	900
H1	[mm]	225	225	225	225	250	250	250
H2	[mm]	293	293	293	323	325	325	325
H3	[mm]	1120	1120	1177	1197	1284	1392	1395

\* 2- and 4-pole TP and TPD pumps from 1.1 to 90 kW are fitted with  motors as standard.

## TP 200-XXX/4

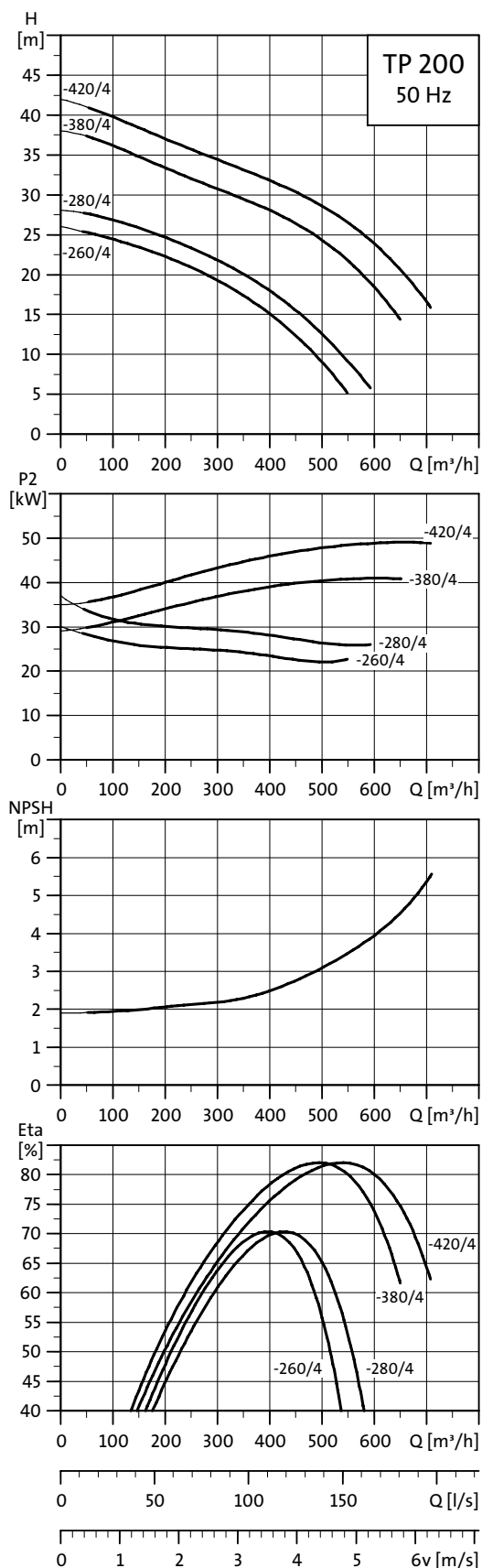

TM02 6843 0805

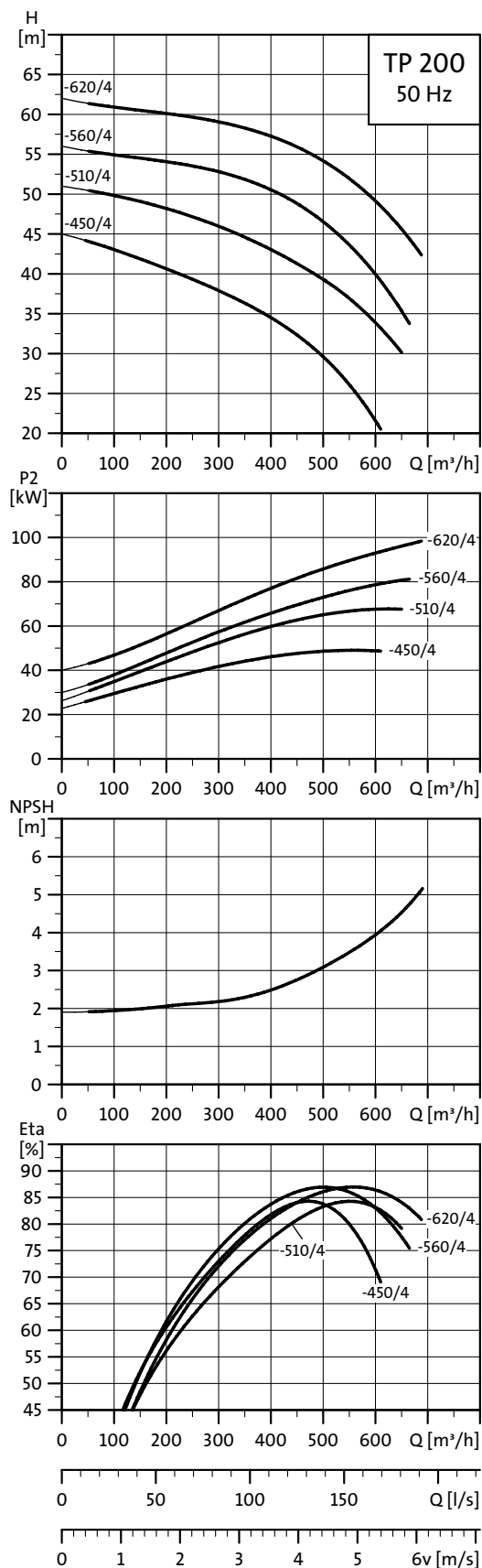

TM02 6844 0504

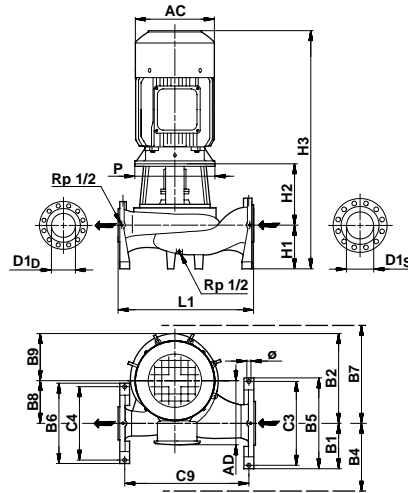

TM02 8350 5004

## Technical data

TP 200		-260/4	-280/4	-380/4	-420/4	-450/4	-510/4	-560/4	-620/4
TPD		-	-	-	-	-	-	-	-
TPE		-	-	-	-	-	-	-	-
TPED		-	-	-	-	-	-	-	-
Series		400	400	400	400	400	400	400	400
IEC size	1-phase TP	-	-	-	-	-	-	-	-
	3-phase TP	200 L	225 S	225 M	250 M	250 M	280 S	280 M	315 S
	1-phase TPE	-	-	-	-	-	-	-	-
	3-phase TPE	-	-	-	-	-	-	-	-
P2*	[kW]	30	37	45	55	55	75	90	110
PN		25	25	25	25	25	25	25	25
T <sub>min</sub> ; T <sub>max</sub>	[°C]	[0;150]	[0;150]	[0;150]	[0;150]	[0;150]	[0;150]	[0;150]	[0;150]
D1 <sub>D</sub> /D1 <sub>S</sub>	[mm]	200/250	200/250	200/250	200/250	200/250	200/250	200/250	200/250
AC	[mm]	402	442	442	495	495	555	555	610
AD	[mm]	305	325	325	392	392	432	432	495
P	[mm]	450	550	550	550	550	550	550	660
B1	[mm]	260	260	260	260	268	268	268	268
B2	[mm]	560	560	560	560	640	640	640	640
B4	[mm]	260	260	260	260	268	268	268	268
B5	[mm]	520	520	520	520	535	535	535	535
B6	[mm]	460	460	460	460	470	470	470	470
B7	[mm]	572	572	572	572	645	645	645	645
B8	[mm]	260	260	260	260	300	300	300	300
B9	[mm]	300	300	300	300	340	340	340	340
C3	[mm]	480	480	480	480	485	485	485	485
C4	[mm]	420	420	420	420	420	420	420	420
C9	[mm]	766	766	766	766	1013	1013	1013	1013
Ø	[mm]	20	20	20	20	20	20	20	20
L1	[mm]	830	830	830	830	1100	1100	1100	1100
H1	[mm]	250	250	250	250	290	290	290	290
H2	[mm]	308	338	338	338	327	327	327	357
H3	[mm]	1217	1237	1297	1405	1434	1437	1547	1579

\* 2- and 4-pole TP and TPD pumps from 1.1 to 90 kW are fitted with  motors as standard.

# Performance curves

DN 250  
4-pole, PN 25

## TP 250-XXX/4

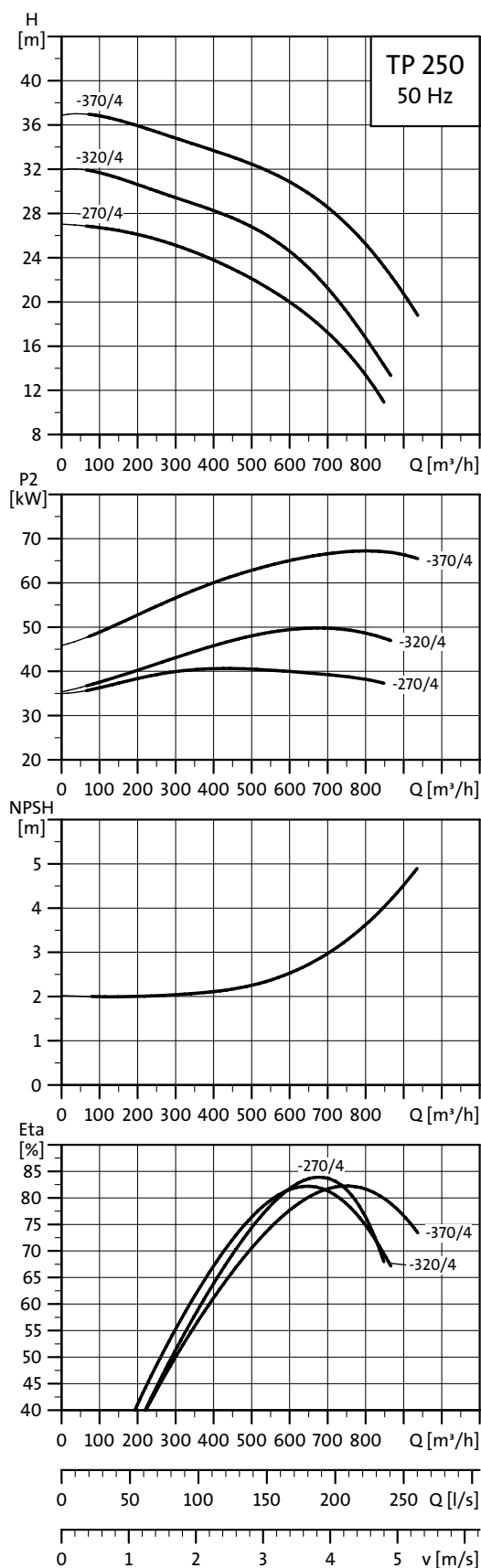

TM02 6845 0504

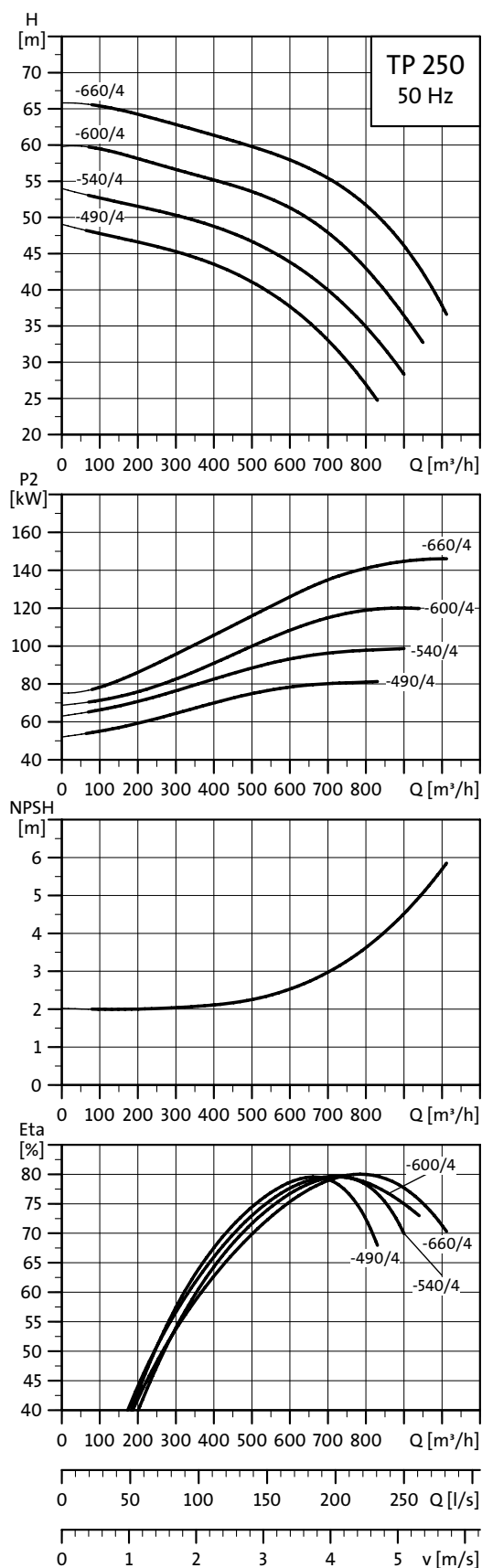

TM02 6846 0504

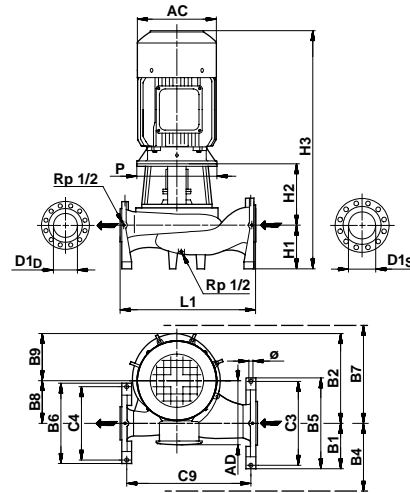

TM02 8350 5004

## Technical data

TP 250		-270/4	-320/4	-370/4	-490/4	-540/4	-600/4	-660/4
TPD		-	-	-	-	-	-	-
TPE		-	-	-	-	-	-	-
TPED		-	-	-	-	-	-	-
Series		400	400	400	400	400	400	400
IEC size	1-phase TP	-	-	-	-	-	-	-
	3-phase TP	225 M	250 M	280 S	280 M	315 S	315 M	315 M
	1-phase TPE	-	-	-	-	-	-	-
	3-phase TPE	-	-	-	-	-	-	-
P2*	[kW]	45	55	75	90	110	132	160
PN		25	25	25	25	25	25	25
T <sub>min</sub> ; T <sub>max</sub>	[°C]	[0;150]	[0;150]	[0;150]	[0;150]	[0;150]	[0;150]	[0;150]
D1 <sub>D</sub> /D1 <sub>S</sub>	[mm]	250/300	250/300	250/300	250/300	250/300	250/300	250/300
AC	[mm]	442	495	555	555	610	610	610
AD	[mm]	325	392	432	432	495	495	495
P	[mm]	550	550	550	660	660	660	660
B1	[mm]	303	303	303	303	303	303	303
B2	[mm]	650	650	650	700	700	700	700
B4	[mm]	303	303	303	303	303	303	303
B5	[mm]	605	605	605	605	605	605	605
B6	[mm]	540	540	540	540	540	540	540
B7	[mm]	647	647	647	720	720	720	720
B8	[mm]	300	300	300	330	330	330	330
B9	[mm]	350	350	350	370	370	370	370
C3	[mm]	550	550	550	550	550	550	550
C4	[mm]	485	485	485	485	485	485	485
C9	[mm]	855	855	855	1106	1106	1106	1106
Ø	[mm]	24	24	24	24	24	24	24
L1	[mm]	950	950	950	1200	1200	1200	1200
H1	[mm]	300	300	300	350	350	350	350
H2	[mm]	368	368	368	373	373	358	358
H3	[mm]	1377	1485	1488	1653	1655	1800	1800

\* 2- and 4-pole TP and TPD pumps from 1.1 to 90 kW are fitted with  motors as standard.

# Performance curves

DN 300  
4-pole, PN 25

## TP 300-XXX/4

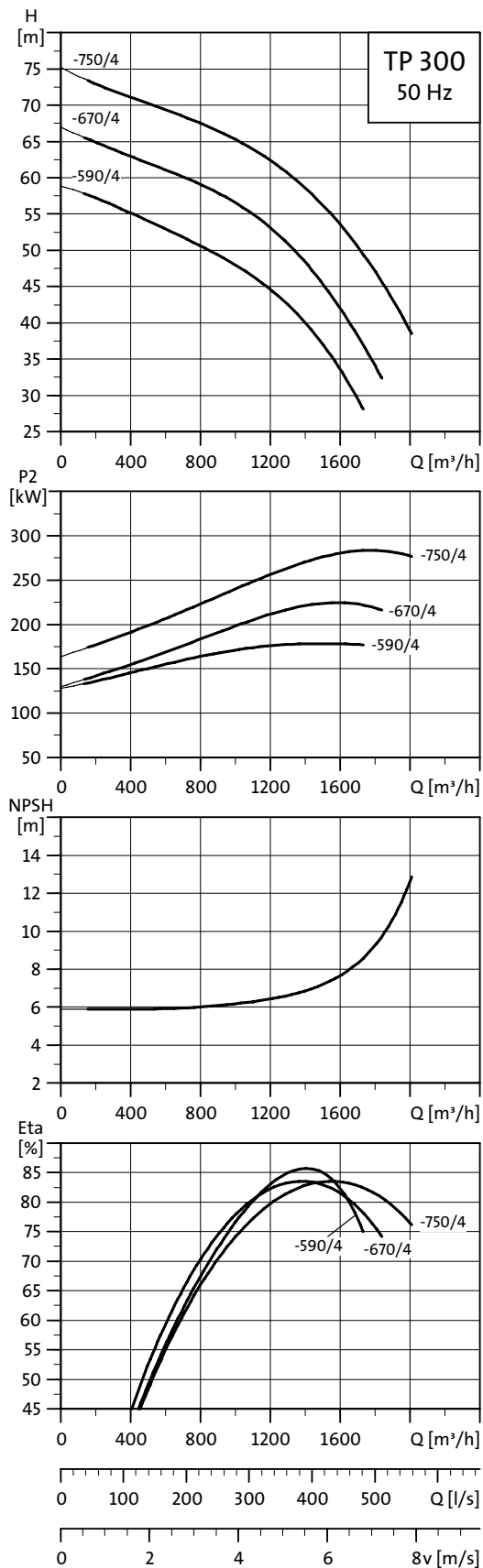

TM02 6847 0504

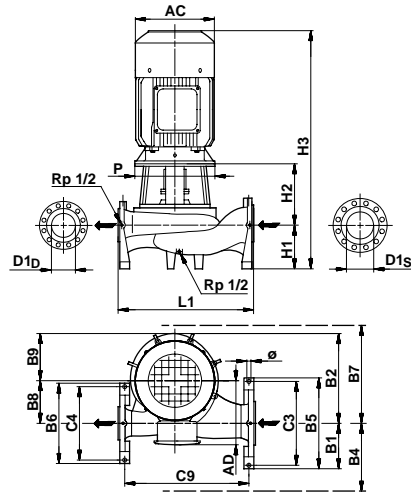

TM02 8350 5004

## Technical data

TP 300		-590/4	-670/4	-750/4
TPD		-	-	-
TPE		-	-	-
TPED		-	-	-
Series		400	400	400
IEC size	1-phase TP	-	-	-
	3-phase TP	315 L	315	315
	1-phase TPE	-	-	-
	3-phase TPE	-	-	-
P2	[kW]	200	250	315
PN		25	25	25
T <sub>min</sub> ; T <sub>max</sub>	[°C]	[0;150]	[0;150]	[0;150]
D1 <sub>D</sub> /D1 <sub>S</sub>	[mm]	300/350	300/350	300/350
AC	[mm]	610	710	710
AD	[mm]	495	690	690
P	[mm]	660	1150	1150
B1	[mm]	338	338	338
B2	[mm]	790	790	790
B4	[mm]	338	338	338
B5	[mm]	675	675	675
B6	[mm]	605	605	605
B7	[mm]	817	817	817
B8	[mm]	370	370	370
B9	[mm]	420	420	420
C3	[mm]	620	620	620
C4	[mm]	550	550	550
C9	[mm]	1204	1204	1204
∅	[mm]	24	24	24
L1	[mm]	1300	1300	1300
H1	[mm]	375	375	375
H2	[mm]	406	446	446
H3	[mm]	2013	2051	2051

# Performance curves

DN 400  
4-pole, PN 25

## TP 400-XXX/4

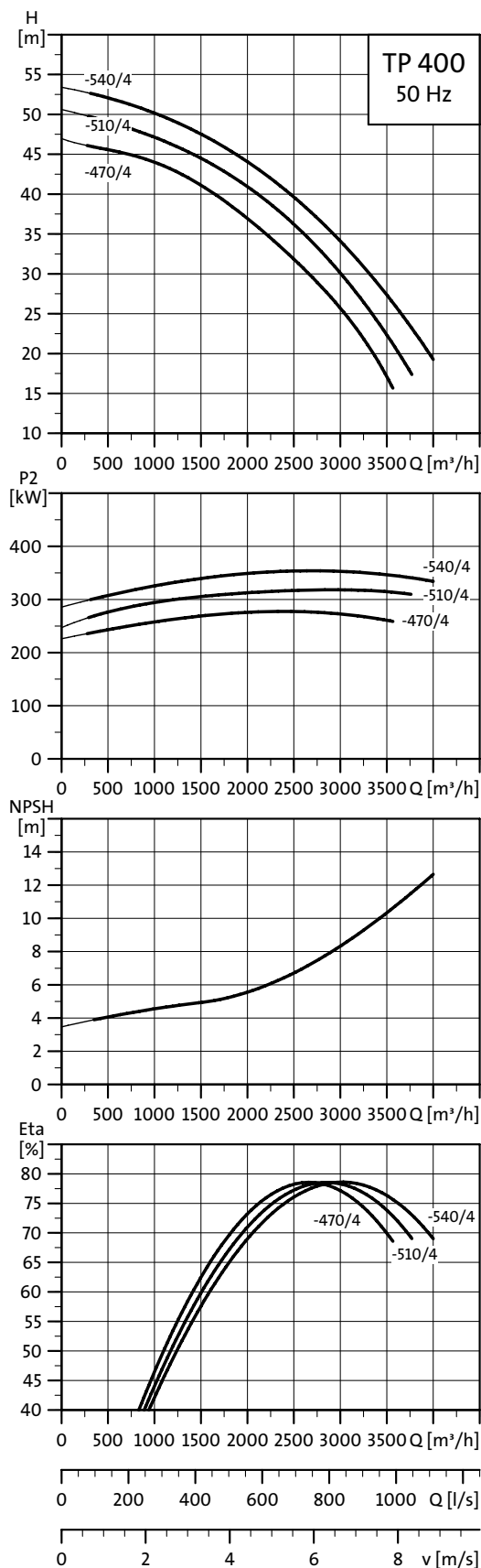

TM02 6848 0504

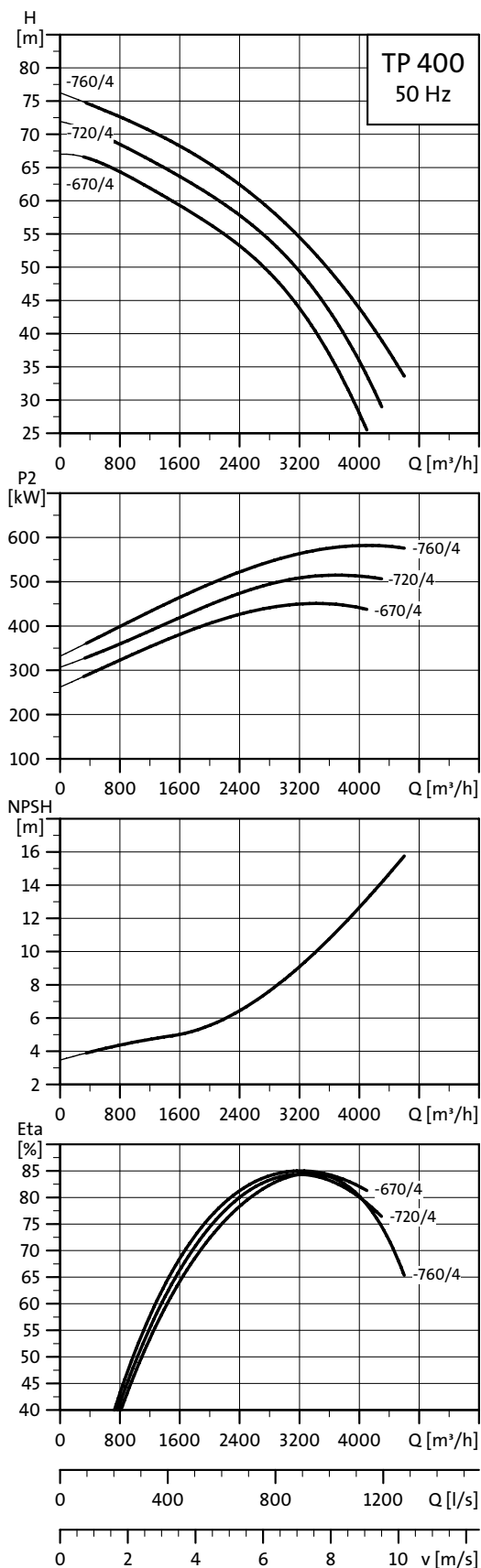

TM02 6849 0504

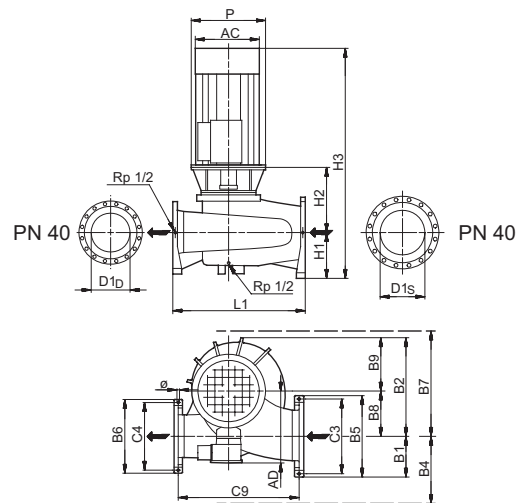

TM02 8351 3307

## Technical data

TP 400		-470/4	-510/4	-540/4	-670/4	-720/4	-760/4
TPD		-	-	-	-	-	-
TPE		-	-	-	-	-	-
TPED		-	-	-	-	-	-
Series		400	400	400	400	400	400
IEC size	1-phase TP	-	-	-	-	-	-
	3-phase TP	315	355	355	355	400	400
	1-phase TPE	-	-	-	-	-	-
	3-phase TPE	-	-	-	-	-	-
P2	[kW]	315	355	400	500	560	630
PN		25	25	25	25	25	25
T <sub>min</sub> : T <sub>max</sub>	[°C]	[0;150]	[0;150]	[0;150]	[0;150]	[0;150]	[0;150]
D1 <sub>D</sub> /D1 <sub>S</sub>	[mm]	400/500	400/500	400/500	400/500	400/500	400/500
AC	[mm]	710	790	790	790	880	880
AD	[mm]	690	725	725	875	925	925
P	[mm]	1150	900	900	900	1150	1150
B1	[mm]	448	448	448	448	448	448
B2	[mm]	1064	1064	1064	1064	1064	1064
B4	[mm]	448	448	448	448	448	448
B5	[mm]	895	895	895	895	895	895
B6	[mm]	800	800	800	800	800	800
B7	[mm]	1066	1066	1066	1066	1066	1066
B8	[mm]	500	500	500	500	500	500
B9	[mm]	564	564	564	564	564	564
C3	[mm]	830	830	830	830	830	830
C4	[mm]	735	735	735	735	735	735
C9	[mm]	1302	1302	1302	1302	1302	1302
Ø	[mm]	27	27	27	27	27	27
L1	[mm]	1400	1400	1400	1400	1400	1400
H1	[mm]	450	450	450	450	450	450
H2	[mm]	706	706	706	706	706	706
H3	[mm]	2386	2611	2611	2611	2771	2771

# Weights and shipping volume

TP, TPD, TPE, TPED

## TP, TPD, TPE, TPED, 2-pole, PN 6, 10, 16

Pump type	Connection		Weights				Shipping volume [m <sup>3</sup> ]	
	D1 <sub>D</sub>	D1 <sub>S</sub>	Net [kg]★		Gross [kg]★		TP/TPD	TPE/TPED
			TP/TPD	TPE/TPED	TP/TPD	TPE/TPED		
TP 25-50/2 R	G 1/2	G 1/2	7.2/-	-	8.2/-	-	0.020/-	-
TP 25-90/2 R	G 1/2	G 1/2	7.5/-	10.7/-	8.5/-	12.7/-	0.020/-	0.036/-
TP 32-50 /2 R	G 2	G 2	7.8/-	-	8.8/-	-	0.020/-	-
TP 32-90/2 R	G 2	G 2	8.2/-	11.8/-	9.2/-	13.8/-	0.020/-	0.036/-
TP, TPD 32-60/2	DN 32	DN 32	15.9/31.8	22.1/39.3	16.9/32.8	25.3/42.7	0.036/0.072	0.064/0.151
TP, TPD 32-120/2	DN 32	DN 32	19.2/38.0	21.3/42.2	20.2/40.0	22.3/44.2	0.036/0.072	0.056/0.072
TP, TPD 32-150/2	DN 32	DN 32	22.8/54.0	29.3/58.5	26.0/57.0	32.5/61.9	0.064/0.082	0.064/0.151
TP, TPD 32-180/2	DN 32	DN 32	24.1/54.0	29.0/58.9	27.3/57.0	32.2/61.9	0.064/0.082	0.064/0.082
TP, TPD 32-230/2	DN 32	DN 32	24.7/54.0	41.3/81.4	27.9/57.0	44.5/85.4	0.064/0.082	0.091/0.221
TP, TPD 32-200/2	DN 32	DN 32	43.3/87.7	49.8/100.6	47.7/103.0	61.7/117.9	0.138/0.3912	0.138/0.3912
TP, TPD 32-250/2	DN 32	DN 32	45.9/92.9	51.9/104.6	50.9/109.4	57.4/123.3	0.138/0.3912	0.184/0.3912
TP, TPD 32-320/2	DN 32	DN 32	51.3/103.7	56.6/114.0	56.6/120.2	62.1/132.7	0.184/0.3912	0.184/0.3912
TP, TPD 32-380/2	DN 32	DN 32	62.9/126.9	64.6/130.0	68.2/144.3	70.1/148.6	0.184/0.4584	0.184/0.5184
TP, TPD 32-460/2	DN 32	DN 32	75.6/151.2	78.7/157.1	82.0/168.6	85.4/175.7	0.2176/0.4584	0.2176/0.5184
TP, TPD 32-580/2	DN 32	DN 32	90.3/180.4	94.8/189.4	105.5/197.9	113.4/208.0	0.2176/0.4584	0.2176/0.5184
TP 40-50/2	DN 40	DN 40	11.5/-	-	12.5/-	-	0.020/-	-
TP, TPD 40-60/2	DN 40	DN 40	20.2/42.0	22.8/47.6	21.2/43.0	25.3/51.6	0.036/0.072	0.056/0.072
TP 40-90/2	DN 40	DN 40	12.0/-	17.3/-	13.0/-	18.3/-	0.020/-	0.025/-
TP, TPD 40-120/2	DN 40	DN 40	19.7/40.5	22.3/45.7	20.7/42.5	24.3/49.7	0.036/0.072	0.056/0.072
TP 40-180/2	DN 40	DN 40	23.5/-	28.7/-	24.5/-	31.9/-	0.036/-	0.064/-
TP, TPD 40-190/2	DN 40	DN 40	28.8/53.8	44.2/81.6	32.0/59.3	47.6/87.1	0.064/0.151	0.091/0.221
TP, TPD 40-230/2	DN 40	DN 40	37.3/57.2	45.8/80.7	40.4/62.7	49.2/86.2	0.064/0.151	0.091/0.221
TP, TPD 40-270/2	DN 40	DN 40	38.9/69.5	36.7/74.9	42.1/75.0	40.1/80.4	0.064/0.151	0.091/0.221
TP, TPD 40-240/2	DN 40	DN 40	53.1/107.3	58.3/117.7	58.3/123.8	63.8/136.3	0.184/0.3912	0.184/0.3912
TP, TPD 40-300/2	DN 40	DN 40	64.5/130.1	66.2/133.4	69.7/147.6	71.7/152.1	0.184/0.4584	0.184/0.5184
TP, TPD 40-360/2	DN 40	DN 40	69.6/140.3	72.6/146.2	74.8/157.8	78.1/164.9	0.184/0.4584	0.184/0.5184
TP, TPD 40-470/2	DN 40	DN 40	90.2/183.2	94.7/192.1	105.4/200.7	113.3/210.8	0.2176/0.4584	0.2176/0.5184
TP, TPD 40-580/2	DN 40	DN 40	104.1/211.0	106.2/215.1	119.3/228.3	124.8/233.8	0.2176/0.4584	0.2176/0.5184
TP, TPD 50-60/2	DN 50	DN 50	20.2/45.0	24.4/49.5	21.2/48.0	27.6/52.9	0.056/0.072	0.064/0.151
TP, TPD 50-120/2	DN 50	DN 50	28.2/56.3	39.8/83.4	29.2/58.3	40.8/85.4	0.056/0.072	0.091/0.221
TP, TPD 50-180/2	DN 50	DN 50	27.7/55.8	41.4/83.1	28.7/57.8	44.6/86.5	0.056/0.072	0.091/0.221
TP, TPD 50-160/2	DN 50	DN 50	46.7/94.0	52.7/105.9	51.7/110.5	64.6/123.3	0.138/0.3912	0.184/0.3912
TP, TPD 50-190/2	DN 50	DN 50	48.8/98.2	54.8/110.0	53.8/114.7	60.3/128.6	0.138/0.3912	0.184/0.3912
TP, TPD 50-240/2	DN 50	DN 50	54.1/108.8	59.4/119.2	59.4/125.3	64.9/137.8	0.184/0.3912	0.184/0.3912
TP, TPD 50-290/2	DN 50	DN 50	65.5/131.6	67.3/134.9	70.8/149.1	72.8/153.6	0.184/0.4584	0.184/0.5184
TP, TPD 50-360/2	DN 50	DN 50	71.6/144.2	74.6/150.1	76.8/161.7	80.1/168.8	0.184/0.4584	0.184/0.5184
TP, TPD 50-430/2	DN 50	DN 50	86.4/174.0	91.0/182.9	101.7/191.4	109.5/201.5	0.184/0.4584	0.184/0.5184
TP, TPD 50-440/2	DN 50	DN 50	112.2/228.4	114.3/232.5	127.4/247.6	132.9/251.2	0.2176/0.5184	0.2176/0.5184
TP, TPD 50-570/2	DN 50	DN 50	149.9/303.8	181.0/366.0	166.9/324.9	199.6/392.2	0.7248/0.6507	0.7248/1.524
TP, TPD 50-710/2	DN 50	DN 50	179.7/363.4	184.8/373.6	196.7/384.5	203.4/399.8	0.7248/0.6507	0.7248/1.524
TP, TPD 50-830/2	DN 50	DN 50	181.9/367.8	209.0/422.0	198.9/388.9	227.6/448.2	0.7248/0.6507	0.7248/1.524
TP, TPD 50-900/2	DN 50	DN 50	196.0/396.1	222.1/448.2	214.6/422.3	240.7/474.4	0.7248/0.6507	0.7248/1.524
TP, TPD 65-60/2	DN 65	DN 65	26.7/53.0	30.4/59.6	27.7/56.0	33.6/63.0	0.056/0.140	0.064/0.151
TP, TPD 65-120/2	DN 65	DN 65	32.2/65.8	40.6/86.6	33.6/67.6	42.6/90.6	0.056/0.140	0.091/0.221
TP, TPD 65-180/2	DN 65	DN 65	38.0/76.9	45.8/92.5	41.0/79.9	48.8/95.5	0.066/0.140	0.091/0.221
TP, TPD 65-190/2	DN 65	DN 65	57.9/116.4	63.1/126.7	63.1/132.9	68.7/145.3	0.184/0.3912	0.184/0.3912
TP, TPD 65-230/2	DN 65	DN 65	69.3/139.2	71.0/142.5	74.5/156.6	76.6/161.1	0.184/0.4584	0.184/0.5184
TP, TPD 65-260/2	DN 65	DN 65	74.3/149.2	77.3/155.1	79.5/166.6	82.9/173.7	0.184/0.4584	0.184/0.5184
TP, TPD 65-340/2	DN 65	DN 65	89.2/178.9	93.7/187.8	104.4/196.4	112.3/206.5	0.184/0.4584	0.184/0.5184
TP, TPD 65-410/2	DN 65	DN 65	103.1/206.7	105.2/210.8	118.3/224.2	123.8/229.5	0.184/0.4584	0.184/0.5184
TP, TPD 65-460/2	DN 65	DN 65	151.4/310.4	182.5/372.5	168.4/331.4	201.1/398.8	0.7248/0.6507	0.7248/1.524
TP, TPD 65-550/2	DN 65	DN 65	180.7/369	185.8/379.1	197.7/390.0	204.4/405.4	0.7248/0.6507	0.7248/1.524
TP, TPD 65-660/2	DN 65	DN 65	182.9/373.4	210.0/427.5	199.9/394.4	228.6/453.8	0.7248/0.6507	0.7248/1.524
TP, TPD 65-720/2	DN 65	DN 65	197.6/402.8	223.8/454.9	216.2/429	242.3/481.2	0.7248/1.524	0.7248/1.524
TP, TPD 65-930/2	DN 65	DN 65	290.9/589.5	-	309.5/615.7	-	0.7248/1.524	-
TP, TPD 80-120/2	DN 80	DN 80	43.5/83.0	52.6/100.7	44.5/86.0	57.1/106.7	0.066/0.140	0.091/0.370

# Weights and shipping volume

TP, TPD, TPE, TPED

Pump type	Connection		Weights				Shipping volume [m <sup>3</sup> ]	
	D1 <sub>D</sub>	D1 <sub>S</sub>	Net [kg]★		Gross [kg]★		TP/TPD	TPE/TPED
			TP/TPD	TPE/TPED	TP/TPD	TPE/TPED		
TP, TPD 80-140/2	DN 80	DN 80	61.0/124.0	66.5/134.0	74.0/141.0	78.5/151.0	0.184/0.3912	0.184/0.3912
TP, TPD 80-180/2	DN 80	DN 80	65.0/132.0	74.5/150.0	78.0/149.0	88.5/180.0	0.184/0.4584	0.184/0.6507
TP, TPD 80-210/2	DN 80	DN 80	78.0/157.0	80.7/162.4	90.0/174.0	94.7/192.4	0.184/0.4584	0.184/0.5184
TP, TPD 80-240/2	DN 80	DN 80	93.0/187.0	97.6/195.2	105.0/204.0	118.6/225.2	0.184/0.4584	0.7248/0.5184
TP, TPD 80-250/2	DN 80	DN 80	101.0/211.0	115.8/238.6	115.0/230.0	136.8/268.6	0.2176/0.5184	0.7248/0.5184
TP, TPD 80-330/2	DN 80	DN 80	148.0/304.0	181.0/370.0	169.0/334.0	203.0/420.6	0.7248/0.6507	0.7248/0.6507
TP, TPD 80-400/2	DN 80	DN 80	160.0/327.0	185.0/377.0	180.0/356.0	205.0/425.0	0.7248/0.6507	0.7248/0.6507
TP, TPD 80-520/2	DN 80	DN 80	176.0/349.0	215.0/427.0	197.0/379.0	236.0/477.0	0.7248/1.524	0.7248/1.524
TP, TPD 80-570/2	DN 80	DN 80	205.0/407.0	228.0/453.0	226.0/457.0	249.0/503.0	0.7248/1.524	0.7248/1.524
TP, TPD 80-700/2	DN 80	DN 80	295.0/587.0	-	316.0/637.0	-	0.7248/1.524	-
TP, TPD 100-120/2	DN 100	DN 100	53.0/108.5	61.1/124.7	55.0/113.5	66.1/130.7	0.140/0.213	0.120/0.370
TP, TPD 100-160/2	DN 100	DN 100	93.0/196.0	95.7/202.4	107.0/246.0	109.7/252.4	0.2176/0.5184	0.2176/0.6507
TP, TPD 100-200/2	DN 100	DN 100	108.0/226.0	112.6/235.2	122.0/276.0	134.6/285.2	0.7248/0.5184	0.7248/0.6507
TP, TPD 100-240/2	DN 100	DN 100	122.0/254.0	127.0/264.0	136.0/304.0	149.0/314.0	0.7248/0.5184	0.7248/0.6507
TP, TPD 100-250/2	DN 100	DN 100	175.0/351.0	206.0/413.0	199.0/401.0	230.0/463.0	0.7248/1.524	0.7248/1.524
TP, TPD 100-310/2	DN 100	DN 100	204.0/410.0	209.0/420.0	228.0/460.0	233.0/470.0	0.7248/1.524	0.7248/1.524
TP, TPD 100-360/2	DN 100	DN 100	207.0/414.0	234.0/468.0	230.0/464.0	257.0/518.0	0.7248/1.524	0.7248/1.524
TP, TPD 100-390/2	DN 100	DN 100	221.0/443.0	247.0/495.0	244.0/493.0	270.0/545.0	0.7248/1.524	0.7248/1.524
TP, TPD 100-480/2	DN 100	DN 100	329.0/661.0	-	-	-	0.797/1.800	-

★ The dimension before the slash applies to the single-head pump and the dimension after the slash applies to the twin-head pump.

## TP, TPD, TPE, TPED, 4-pole, PN 6, 10, 16

Pump type	Connection		Weights				Shipping volume [m <sup>3</sup> ]★	
	D1 <sub>D</sub>	D1 <sub>S</sub>	Net [kg]★		Gross [kg]★		TP/TPD	TPE/TPED
			TP/TPD	TPE/TPED	TP/TPD	TPE/TPED		
TP, TPD 32-30/4	DN 32	DN 32	15.9/30.8	21.7/38.8	16.9/31.8	24.9/42.2	0.036/0.072	0.064/0.151
TP, TPD 32-40/4	DN 32	DN 32	25.2/32.0	29.1/54.7	28.4/33.0	32.3/58.1	0.064/0.072	0.064/0.151
TP, TPD 32-60/4	DN 32	DN 32	25.2/50.7	29.1/54.7	28.4/53.7	32.3/58.1	0.036/0.082	0.064/0.151
TP, TPD 32-80/4	DN 32	DN 32	35.2/69.9	36.9/74.9	40.2/86.4	48.8/92.2	0.138/0.3912	0.184/0.3912
TP, TPD 32-100/4	DN 32	DN 32	36.3/71.7	37.2/75.5	41.2/88.3	49.1/92.8	0.138/0.3912	0.184/0.3912
TP, TPD 32-120/4	DN 32	DN 32	49.7/94.2	48.3/96.5	55.8/110.7	61.1/113.8	0.1632/0.3912	0.2176/0.3912
TP, TPD 40-30/4	DN 40	DN 40	17.4/33.0	23.3/41.3	18.4/34.3	26.5/44.7	0.036/0.072	0.064/0.151
TP 40-60/4	DN 40	DN 40	22.5/42.0	27.2/-	23.5/43.0	30.4/-	0.036/0.072	0.064/-
TP, TPD 40-90/4	DN 40	DN 40	28.9/50.9	32.8/49.3	32.3/56.4	36.0/54.8	0.076/0.151	0.076/0.151
TP, TPD 40-100/4	DN 40	DN 40	41.0/83.1	42.2/85.6	45.9/99.6	54.1/103.0	0.138/0.3912	0.184/0.3912
TP, TPD 40-130/4	DN 40	DN 40	48.4/99.6	58.6/120.0	54.4/116.1	71.4/137.4	0.1632/0.3912	0.184/0.3912
TP, TPD 40-160/4	DN 40	DN 40	54.5/112.0	64.5/131.7	60.6/128.5	71.2/150.3	0.2176/0.3912	0.2176/0.3912
TP, TPD 50-30/4	DN 50	DN 50	24.4/46.3	30.3/51.9	25.4/48.3	33.5/55.3	0.036/0.072	0.064/0.151
TP, TPD 50-60/4	DN 50	DN 50	25.5/50.5	28.5/56.4	26.5/52.5	30.5/61.9	0.056/0.072	0.056/0.072
TP, TPD 50-90/4	DN 50	DN 50	43.0/87.0	44.2/89.5	47.9/103.5	56.1/106.9	0.138/0.3912	0.184/0.3912
TP, TPD 50-110/4	DN 50	DN 50	56.5/117.1	66.7/137.5	62.5/136.3	79.5/167.5	0.1632/0.5184	0.2176/0.5184
TP, TPD 50-130/4	DN 50	DN 50	62.7/129.4	72.6/149.1	68.7/148.6	79.4/167.8	0.1632/0.5184	0.2176/0.5184
TP, TPD 50-160/4	DN 50	DN 50	65.1/134.2	73.9/151.7	71.1/153.4	80.7/170.4	0.2176/0.5184	0.2176/0.5184
TP, TPD 50-190/4	DN 50	DN 50	72.4/148.9	83.8/171.6	78.8/168.1	90.6/190.2	0.2176/0.5184	0.2176/0.5184
TP, TPD 50-230/4	DN 50	DN 50	76.9/157.9	80.9/165.8	83.3/177.1	87.7/184.4	0.2176/0.5184	0.2176/0.5184
TP, TPD 65-30/4	DN 65	DN 65	33.0/56.5	37.8/62.1	35.0/59.5	41.0/65.5	0.056/0.140	0.064/0.151
TP, TPD 65-60/4	DN 65	DN 65	33.7/63.8	36.3/69.0	34.7/66.8	38.8/79.5	0.056/0.140	0.056/0.140
TP, TPD 65-90/4	DN 65	DN 65	47.1/94.9	57.3/115.3	52.1/111.4	69.4/132.6	0.1632/0.3912	0.184/0.3912
TP, TPD 65-110/4	DN 65	DN 65	64.2/136.1	74.2/155.8	70.3/152.6	80.9/174.4	0.2176/0.3912	0.2176/0.4584
TP, TPD 65-130/4	DN 65	DN 65	66.5/140.6	75.3/158.1	72.5/157.1	82.1/176.7	0.2176/0.3912	0.2176/0.4584
TP, TPD 65-150/4	DN 65	DN 65	73.5/154.6	84.9/177.3	79.9/172.0	91.7/195.9	0.2176/0.4584	0.2176/0.5184
TP, TPD 65-170/4	DN 65	DN 65	77.8/163.2	81.8/171.1	84.2/180.6	88.6/189.7	0.2176/0.4584	0.2176/0.5184
TP, TPD 65-240/4	DN 65	DN 65	82.7/173.0	101.8/210.9	89.1/190.5	108.5/229.6	0.2176/0.4584	0.2176/0.5184
TP, TPD 80-30/4	DN 80	DN 80	37.5/68.3	41.1/72.8	39.5/71.3	44.3/76.2	0.056/0.140	0.064/0.151
TP, TPD 80-60/4	DN 80	DN 80	38.6/71.6	50.4/95.3	40.6/74.6	53.4/100.8	0.066/0.140	0.091/0.370
TP, TPD 80-70/4	DN 80	DN 80	68.0/143.0	74.1/156.2	81.0/161.0	87.1/173.2	0.2176/0.3912	0.2176/0.4584
TP, TPD 80-90/4	DN 80	DN 80	71.0/150.0	75.0/158.0	84.0/167.0	88.0/175.0	0.2176/0.4584	0.2176/0.4584

# Weights and shipping volume

TP, TPD, TPE, TPED

Pump type	Connection		Weights				Shipping volume [m <sup>3</sup> ]*	
	D <sub>1D</sub>	D <sub>1S</sub>	Net [kg]*		Gross [kg]*		TP/TPD	TPE/TPED
			TP/TPD	TPE/TPED	TP/TPD	TPE/TPED		
TP, TPD 80-110/4	DN 80	DN 80	76.0/159.0	84.5/176.0	89.0/176.0	98.5/206.0	0.2176/0.4584	0.2176/0.5184
TP, TPD 80-150/4	DN 80	DN 80	84.0/164.0	87.5/171.0	98.0/184.0	101.5/201.0	0.2176/0.5184	0.2176/0.6507
TP, TPD 80-170/4	DN 80	DN 80	103.0/203.0	106.3/209.6	117.0/222.0	120.3/239.6	0.2176/0.5184	0.7248/0.6507
TP, TPD 80-240/4	DN 80	DN 80	194.0/393.0	180.8/366.6	218.0/443.0	204.8/417.6	0.9696/1.524	0.9696/1.524
TP, TPD 80-270/4	DN 80	DN 80	205.0/415.0	205.0/416.0	229.0/465.0	230.0/466.0	0.9696/1.524	0.9696/1.524
TP, TPD 80-340/4	DN 80	DN 80	239.0/484.0	233.0/472.0	263.0/534.0	258.0/522.0	0.9696/1.524	0.9696/1.524
TP, TPD 100-30/4	DN 100	DN 100	41.0/85.0	43.0/93.0	44.0/90.0	46.2/103.0	0.140/0.213	0.151/0.220
TP, TPD 100-60/4	DN 100	DN 100	53.0/109.0	63.7/122.6	56.0/114.0	67.7/127.6	0.140/0.213	0.120/0.370
TP, TPD 100-70/4	DN 100	DN 100	96.0/193.0	100.0/201.0	110.0/210.0	114.0/251.0	0.7248/0.6507	0.7248/0.6507
TP, TPD 100-90/4	DN 100	DN 100	100.0/202.0	109.0/218.0	125.0/252.0	133.0/268.0	0.7248/0.6507	0.7248/0.6507
TP, TPD 100-110/4	DN 100	DN 100	103.0/207.0	106.5/213.0	127.0/257.0	130.5/264.0	0.7248/0.6507	0.7248/0.6507
TP, TPD 100-130/4	DN 100	DN 100	141.0/286.0	144.3/292.6	166.0/336.0	169.3/342.6	0.7248/1.524	0.7248/1.524
TP, TPD 100-170/4	DN 100	DN 100	168.0/340.0	155.8/313.6	192.0/390.0	189.8/364.6	0.7248/1.524	0.7248/1.524
TP, TPD 100-200/4	DN 100	DN 100	239.0/499.0	240.0/500.0	264.0/549.0	290.0/550.0	0.9696/1.524	0.9696/1.524
TP, TPD 100-250/4	DN 100	DN 100	274.0/568.0	268.0/556.0	298.0/618.0	318.0/606.0	0.9696/1.524	0.9696/1.524
TP, TPD 100-330/4	DN 100	DN 100	285.0/589.0	291.0/601.0	309.0/640.0	341.0/652.0	0.9696/1.524	0.9696/1.524
TP, TPD 100-370/4	DN 100	DN 100	302.0/623.0	330.0/679.0	344.0/674.0	380.0/730.0	0.9696/1.524	0.9696/1.800
TP, TPD 100-410/4	DN 100	DN 100	312.0/645.0	-	354.0/695.0	-	0.9696/1.800	-
TP, TPD 125-110/4	DN 125	DN 125	185.0/397.0	188.3/403.6	215.0/447.0	218.3/453.6	0.9696/1.524	0.9696/1.524
TP, TPD 125-130/4	DN 125	DN 125	212.0/450.0	198.8/400.6	242.0/501.0	249.8/474.6	0.9696/1.524	0.9696/1.524
TP, TPD 125-160/4	DN 125	DN 125	222.0/471.0	223.0/472.0	252.0/522.0	273.0/523.0	0.9696/1.524	0.9696/1.524
TP, TPD 125-210/4	DN 125	DN 125	298.0/604.0	292.0/592.0	328.0/654.0	342.0/642.0	0.9696/1.524	0.9696/1.524
TP, TPD 125-250/4	DN 125	DN 125	308.0/623.0	314.0/635.0	358.0/674.0	364.0/686.0	0.9696/1.800	0.9696/1.524
TP, TPD 125-320/4	DN 125	DN 125	326.0/659.0	354.0/715.0	383.0/717.0	424.0/766.0	0.9696/1.800	0.9696/1.524
TP, TPD 125-360/4	DN 125	DN 125	336.0/681.0	-	394.0/738.0	-	0.9696/1.800	-
TP, TPD 125-420/4	DN 125	DN 125	435.0/878.0	-	492.0/935.0	-	1.800/1.800	-
TP, TPD 150-130/4	DN 150	DN 150	285.0/574.0	286.0/575.0	315.0/624.0	336.0/625.0	0.9696/1.524	0.9696/1.524
TP, TPD 150-160/4	DN 150	DN 150	320.0/643.0	314.0/631.0	350.0/693.0	364.0/681.0	0.9696/1.524	0.9696/1.524
TP, TPD 150-200/4	DN 150	DN 150	330.0/663.0	336.0/675.0	380.0/714.0	386.0/756.0	0.9696/1.800	0.9696/1.800
TP, TPD 150-220/4	DN 150	DN 150	347.0/697.0	375.0/753.0	404.0/755.0	425.0/804.0	0.9696/1.800	0.9696/1.800
TP, TPD 150-250/4	DN 150	DN 150	358.0/718.0	-	415.0/776.0	-	0.9696/1.800	-
TP 150-260/4	DN 150	DN 150	356.0/-	388/-	529.0/-	561.0/-	2.3/-	2.3/-
TP 150-280/4	DN 150	DN 150	377.0/-	-	621.0/-	-	2.3/-	-
TP 150-340/4	DN 150	DN 150	437.0/-	-	607.0/-	-	2.3/-	-
TP 150-390/4	DN 150	DN 150	540.0/-	-	709.0/-	-	2.3/-	-
TP 200-180/4	DN 200	DN 200	462.0/-	-	635.0/-	-	2.3/-	-
TP 200-220/4	DN 200	DN 200	521.0/-	-	694.0/-	-	2.3/-	-
TP 200-250/4	DN 200	DN 200	625.0/-	-	794.0/-	-	2.3/-	-
TP 200-270/4	DN 200	DN 200	666.0/-	-	835.0/-	-	2.3/-	-
TP 200-320/4	DN 200	DN 200	817.0/-	-	1016.0/-	-	3.1/-	-
TP 200-330/4	DN 200	DN 200	720.0/-	-	923.0/-	-	3.1/-	-
TP 200-360/4	DN 200	DN 200	761.0/-	-	964.0/-	-	3.1/-	-
TP 200-400/4	DN 200	DN 200	911.0/-	-	1110.0/-	-	3.1/-	-
TP 200-410/4	DN 200	DN 200	935.0/-	-	1133.0/-	-	3.1/-	-
TP 200-470/4	DN 200	DN 200	1029.0/-	-	1228.0/-	-	3.1/-	-
TP 200-530/4	DN 200	DN 200	1131.0/-	-	1364.0/-	-	4.6/-	-
TP 200-590/4	DN 200	DN 200	1331.0/-	-	1563.0/-	-	4.6/-	-
TP 200-660/4	DN 200	DN 200	1488.0/-	-	1720.0/-	-	4.6/-	-
TP 250-280/4	DN 250	DN 300	690.0	-	875.0	-	3.13	-
TP 250-310/4	DN 250	DN 300	820.0	-	1005.0	-	3.13	-
TP 250-390/4	DN 250	DN 300	935.0	-	1120.0	-	3.13	-

\* The dimension before the slash applies to the single-head pump and the dimension after the slash applies to the twin-head pump.

# Weights and shipping volume

TP, TPD, TPE, TPED

## TP, TPD, 6-pole, PN 6, 10, 16

Pump type	Connection		Weights				Shipping volume [m <sup>3</sup> ]*	
	D1 <sub>D</sub>	D1 <sub>S</sub>	Net [kg]*		Gross [kg]*		TP/TPD	TPE/TPED
			TP/TPD	TPE/TPED	TP/TPD	TPE/TPED		
TP, TPD 125-60/6	DN 125	DN 125	157.0/341.0	-	187.0/391.0	-	0.9696/1.524	-
TP, TPD 125-70/6	DN 125	DN 125	166.0/359.0	-	196.0/409.0	-	0.9696/1.524	-
TP, TPD 125-90/6	DN 125	DN 125	230.0/469.0	-	260.0/519.0	-	0.9696/1.524	-
TP, TPD 125-110/6	DN 125	DN 125	237.0/482.0	-	267.0/533.0	-	0.9696/1.524	-
TP, TPD 125-140/6	DN 125	DN 125	244.0/496.0	-	274.0/546.0	-	0.9696/1.524	-
TP, TPD 125-170/6	DN 125	DN 125	280.0/567.0	-	310.0/618.0	-	0.9696/1.524	-
TP, TPD 150-60/6	DN 150	DN 150	229.0/461.0	-	259.0/512.0	-	0.9696/1.524	-
TP, TPD 150-70/6	DN 150	DN 150	253.0/508.0	-	283.0/558.0	-	0.9696/1.524	-
TP, TPD 150-90/6	DN 150	DN 150	259.0/522.0	-	289.0/572.0	-	0.9696/1.524	-
TP, TPD 150-110/6	DN 150	DN 150	265.0/534.0	-	295.0/584.0	-	0.9696/1.524	-

\* The dimension before the slash applies to the single-head pump and the dimension after the slash applies to the twin-head pump.

## TP, 2-pole, PN 25

Pump type	Connection		Weights		Shipping volume [m <sup>3</sup> ]
	D1 <sub>D</sub>	D1 <sub>S</sub>	Net [kg]	Gross [kg]	
TP 100-620/2	DN 100	DN 125	374.0	529.0	2.29
TP 100-700/2	DN 100	DN 125	490.0	645.0	2.29
TP 100-820/2	DN 100	DN 125	580.0	735.0	2.29
TP 100-960/2	DN 100	DN 125	690.0	875.0	3.13
TP 100-1050/2	DN 100	DN 125	755.0	940.0	3.13
TP 100-1180/2	DN 100	DN 125	840.0	1025.0	3.13
TP 100-1400/2	DN 100	DN 125	1015.0	1200.0	3.13
TP 100-1530/2	DN 100	DN 125	1140.0	1325.0	3.13
TP 100-1680/2	DN 100	DN 125	1280.0	1500.0	4.57

## TP, 4-pole, PN 25

Pump type	Connection		Weights		Shipping volume [m <sup>3</sup> ]
	D1 <sub>D</sub>	D1 <sub>S</sub>	Net [kg]	Gross [kg]	
TP 100-190/4	DN 100	DN 125	227.0	257.0	0.72
TP 100-220/4	DN 100	DN 125	237.0	267.0	0.72
TP 100-260/4	DN 100	DN 125	260.0	290.0	0.72
TP 100-270/4	DN 100	DN 125	325.0	358.0	0.70
TP 100-320/4	DN 100	DN 125	344.0	377.0	0.70
TP 100-380/4	DN 100	DN 125	351.0	384.0	0.70
TP 100-420/4	DN 100	DN 125	371.0	404.0	0.70
TP 125-150/4	DN 125	DN 150	257.0	290.0	0.70
TP 125-200/4	DN 125	DN 150	280.0	313.0	0.70
TP 125-240/4	DN 125	DN 150	299.0	332.0	0.70
TP 125-280/4	DN 125	DN 150	299.0	332.0	0.70
TP 125-310/4	DN 125	DN 150	371.0	404.0	0.70
TP 125-370/4	DN 125	DN 150	391.0	424.0	0.70
TP 125-430/4	DN 125	DN 150	444.0	599.0	2.29
TP 150-240/4	DN 150	DN 200	411.0	566.0	2.29
TP 150-270/4	DN 150	DN 200	431.0	586.0	2.29
TP 150-320/4	DN 150	DN 200	484.0	639.0	2.29
TP 150-350/4	DN 150	DN 200	575.0	730.0	2.29
TP 150-430/4	DN 150	DN 200	655.0	810.0	2.29
TP 150-530/4	DN 150	DN 200	785.0	970.0	3.13
TP 150-650/4	DN 150	DN 200	900.0	1085.0	3.13
TP 200-270/4	DN 200	DN 250	539.0	694.0	2.29
TP 200-280/4	DN 200	DN 250	630.0	785.0	2.29
TP 200-380/4	DN 200	DN 250	670.0	825.0	2.29
TP 200-420/4	DN 200	DN 250	800.0	985.0	3.13
TP 200-450/4	DN 200	DN 250	860.0	1045.0	3.13

# Weights and shipping volume

TP, TPD, TPE, TPED

Pump type	Connection		Weights		Shipping volume [m <sup>3</sup> ]
	D1 <sub>D</sub>	D1 <sub>S</sub>	Net [kg]	Gross [kg]	
TP 200-510/4	DN 200	DN 250	975.0	1160.0	3.13
TP 200-560/4	DN 200	DN 250	1075.0	1260.0	3.13
TP 200-620/4	DN 200	DN 250	1210.0	1430.0	4.57
TP 250-270/4	DN 250	DN 300	780.0	965.0	3.13
TP 250-320/4	DN 250	DN 300	910.0	1095.0	3.13
TP 250-370/4	DN 250	DN 300	1025.0	1210.0	3.13
TP 250-490/4	DN 250	DN 300	1225.0	1445.0	4.57
TP 250-540/4	DN 250	DN 300	1360.0	1580.0	4.57
TP 250-600/4	DN 250	DN 300	1515.0	1735.0	4.57
TP 250-660/4	DN 250	DN 300	1655.0	1875.0	4.57
TP 300-590/4	DN 300	DN 350	1935.0	2245.0	5.88
TP 300-670/4	DN 300	DN 350	1930.0	2240.0	5.88
TP 300-750/4	DN 300	DN 350	2130.0	2440.0	5.88
TP 400-470/4	DN 400	DN 500	3700.0	4140.0	10.76
TP 400-510/4	DN 400	DN 500	4100.0	4540.0	10.76
TP 400-540/4	DN 400	DN 500	4200.0	4640.0	10.76
TP 400-670/4	DN 400	DN 500	4400.0	4840.0	10.76
TP 400-720/4	DN 400	DN 500	5000.0	5440.0	10.76
TP 400-760/4	DN 400	DN 500	5200.0	5640.0	10.76

## Unions and valves

### Cast iron pumps

A union kit consists of two cast iron union tails, two cast iron union nuts and two EPDM gaskets.

Pump type, union connection	Pressure stage	Size	Product number
TP, TPE 25 R	PN 10	Rp 3/4	529921
		Rp 1	529922
		Rp 1 1/4	529924
TP, TPE 32 R	PN 10	Rp 1	509921
		Rp 1 1/4	509922

A valve kit consists of two brass valves, two brass union nuts and two EPDM gaskets.

The valve housing is of pressure die-cast brass.

Pump type, valve connection	Pressure stage	Size	Product number
TP, TPE 25 R	PN 10	Rp 3/4	519805
		Rp 1	519806
		Rp 1 1/4	519807
TP, TPE 32 R	PN 10	Rp 1 1/4	505539

### Bronze pumps

A union kit consists of two bronze union tails, two brass union nuts, and two EPDM gaskets.

The valve housing is of pressure die-cast brass.

Pump type, union connection	Pressure stage	Size	Product number
TP, TPE 25 R B	PN 10	Rp 3/4	529971
		Rp 1	529972
TP, TPE 32 R B	PN 10	Rp 1 1/4	509971

A valve kit consists of two brass valves, two brass union nuts and two EPDM gaskets.

The valve housing is of pressure die-cast brass.

Pump type, valve connection	Pressure stage	Size	Product number
TP, TPE 25 R B	PN 10	Rp 3/4	519805
		Rp 1	519806
		Rp 1 1/4	519807
TP, TPE 32 R B	PN 10	Rp 1 1/4	505539

## Counter flanges

### Cast iron pumps

A flange kit consists of two steel flanges, two gaskets of asbestos-free material IT 200, and the requisite number of bolts.

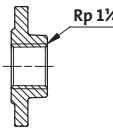
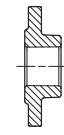
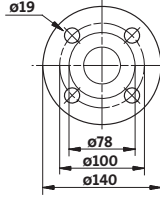
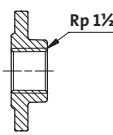
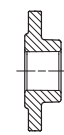
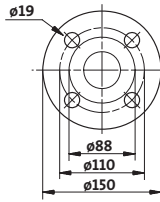
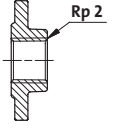
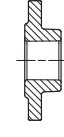
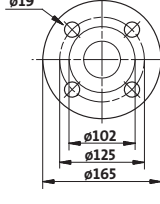
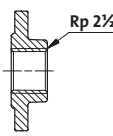
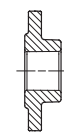
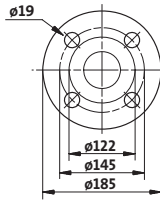
Counter flange			Pump type	Description	Rated pressure	Pipework connection	Product number
 <p>Threaded</p>	 <p>For welding</p>		<p>TM03 0478 5204</p> <p><b>TP, TPE 32 TPD, TPED 32</b></p>	Threaded	10 bar, EN 1092-2	Rp 1 1/4	539703
				For welding	10 bar, EN 1092-2	32 mm, nominal	539704
				Threaded	16 bar, EN 1092-2	Rp 1 1/4	539703
				For welding	16 bar, EN 1092-2	32 mm, nominal	539704
 <p>Threaded</p>	 <p>For welding</p>		<p>TM03 0479 5204</p> <p><b>TP, TPE 40 TPD, TPED 40</b></p>	Threaded	10 bar, EN 1092-2	Rp 1 1/2	539701
				For welding	10 bar, EN 1092-2	40 mm, nominal	539702
				Threaded	16 bar, EN 1092-2	Rp 1 1/2	539701
				For welding	16 bar, EN 1092-2	40 mm, nominal	539702
 <p>Threaded</p>	 <p>For welding</p>		<p>TM03 0480 5204</p> <p><b>TP, TPE 50 TPD, TPED 50</b></p>	Threaded	10 bar, EN 1092-2	Rp 2	549801
				For welding	10 bar, EN 1092-2	50 mm, nominal	549802
				Threaded	16 bar, EN 1092-2	Rp 2	549801
				For welding	16 bar, EN 1092-2	50 mm, nominal	549802
 <p>Threaded</p>	 <p>For welding</p>		<p>TM03 0481 5204</p> <p><b>TP, TPE 65 TPD, TPED 65</b></p>	Threaded	10 bar, EN 1092-2	Rp 2 1/2	559801
				For welding	10 bar, EN 1092-2	65 mm, nominal	559802
				Threaded	16 bar, EN 1092-2	Rp 2 1/2	559801
				For welding	16 bar, EN 1092-2	65 mm, nominal	559802

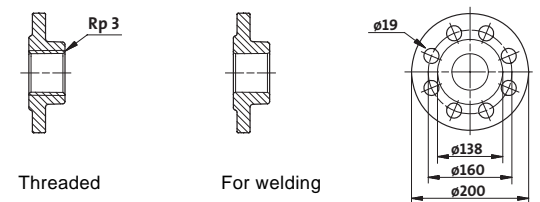
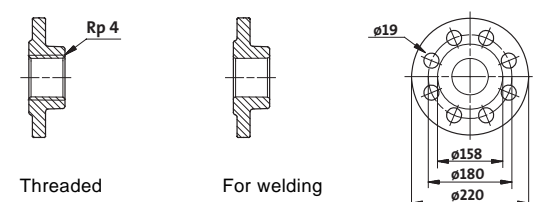
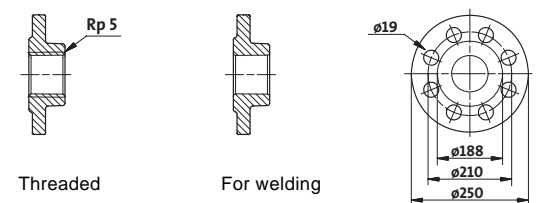
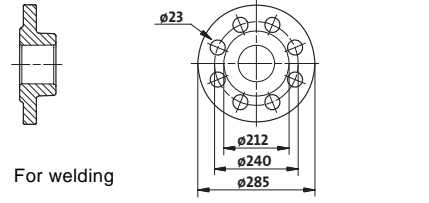
Counter flange	Pump type	Description	Rated pressure	Pipework connection	Product number
 <p>Threaded</p> <p>For welding</p>	<p>TM03 0482 5204</p> <p><b>TP, TPE 80</b> <b>TPD, TPED 80</b></p>	Threaded	6 bar, EN 1092-2	Rp 3	569902
		For welding	6 bar, EN 1092-2	80 mm, nominal	569901
		Threaded	10 bar, EN 1092-2	Rp 3	569802
		For welding	10 bar, EN 1092-2	80 mm, nominal	569801
		Threaded	16 bar, EN 1092-2	Rp 3	569802
		For welding	16 bar, EN 1092-2	80 mm, nominal	569801
 <p>Threaded</p> <p>For welding</p>	<p>TM03 0483 5204</p> <p><b>TP, TPE 100</b> <b>TPD, TPED 100</b></p>	Threaded	6 bar, EN 1092-2	Rp 4	579901
		For welding	6 bar, EN 1092-2	100 mm, nominal	579902
		Threaded	10 bar, EN 1092-2	Rp 4	579801
		For welding	10 bar, EN 1092-2	100 mm, nominal	579802
		Threaded	16 bar, EN 1092-2	Rp 4	579801
		For welding	16 bar, EN 1092-2	100 mm, nominal	579802
 <p>Threaded</p> <p>For welding</p>	<p>TM03 0484 5204</p> <p><b>TP, TPE 125</b> <b>TPD, TPED 125</b></p>	Threaded	10 bar, EN 1092-2	Rp 5	485367
		For welding	10 bar, EN 1092-2	125 mm, nominal	485368
		Threaded	16 bar, EN 1092-2	Rp 5	485367
		For welding	16 bar, EN 1092-2	125 mm, nominal	485368
		For welding	10 bar, EN 1092-2	150 mm, nominal	S1111600
 <p>For welding</p>	<p>TM03 0485 5204</p> <p><b>TP, TPE 150</b> <b>TPD, TPED 150</b></p>	For welding	16 bar, EN 1092-2	150 mm, nominal	S1111600
		For welding	10 bar, EN 1092-2	150 mm, nominal	S1111600

## Bronze pumps

A flange kit consists of two bronze flanges, two gaskets of asbestos-free material IT 200, and the requisite number of bolts.

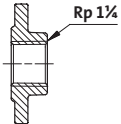
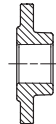
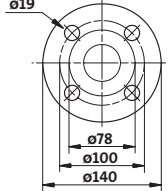
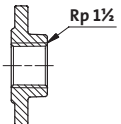
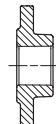
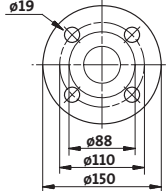
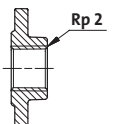
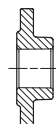
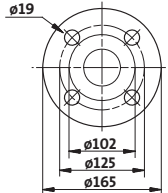
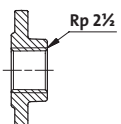
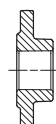
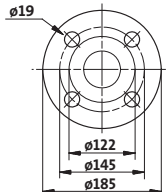
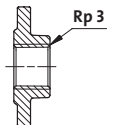
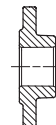
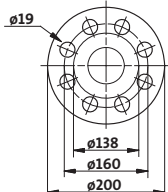
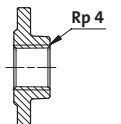
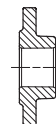
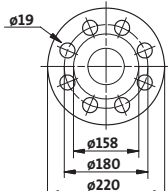
Counter flange		Pump type	Description	Rated pressure	Pipework connection	Product number
			Threaded	10 bar, EN 1092-2	Rp 1 1/4	96427029
		 TM03 0478 5204	For welding	10 bar, EN 1092-2	32 mm, nominal	96427030
Threaded	For welding		Threaded	16 bar, EN 1092-2	Rp 1 1/4	96427029
			For welding	16 bar, EN 1092-2	32 mm, nominal	96427030
			Threaded	10 bar, EN 1092-2	Rp 1 1/2	539711
		 TM03 0479 5204	For welding	10 bar, EN 1092-2	40 mm, nominal	539712
Threaded	For welding		Threaded	16 bar, EN 1092-2	Rp 1 1/2	539711
			For welding	16 bar, EN 1092-2	40 mm, nominal	539712
			Threaded	10 bar, EN 1092-2	Rp 2	549811
		 TM03 0480 5204	For welding	10 bar, EN 1092-2	50 mm, nominal	549812
Threaded	For welding		Threaded	10 bar, EN 1092-2	Rp 2	549811
		 TM03 0481 5204	For welding	10 bar, EN 1092-2	65 mm, nominal	559812
Threaded	For welding		Threaded	10 bar, EN 1092-2	Rp 2 1/2	559811
		 TM03 0482 5204	For welding	6 bar, EN 1092-2	80 mm, nominal	569911
Threaded	For welding		Threaded	10 bar, EN 1092-2	Rp 3	569812
			For welding	10 bar, EN 1092-2	80 mm, nominal	569811
			Threaded	6 bar, EN 1092-2	Rp 4	96405737
		 TM03 0485 5204	For welding	10 bar, EN 1092-2	Rp 4	96405738
Threaded	For welding		Threaded	10 bar, EN 1092-2	Rp 4	96405738

## Base plates

**Note:** Base plates are supplied as standard with TP, TPD, TPE, TPED pumps with 11 kW motors and above.

### TP, TPE Series 100 and 200

Pump type	Hexagon head screws	Product number
TP, TPE 32 ★ TP, TPE 40 TP, TPE 50 TP 65-60/2 TP, TPE 65-120/2 TP 65-180/2	2 x M12 x 20 mm	96405915
TP 65-30/4 TP, TPE 65-60/4 TP, TPE 80 TP, TPE 100	2 x M16 x 30 mm	96405914

★ Except TPE 32-90.

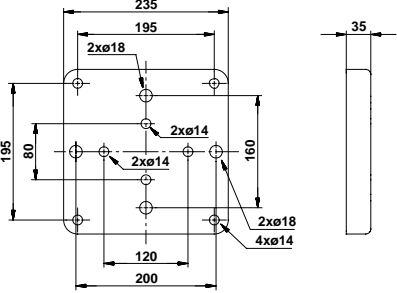
Drawing	Product number
	96405915 96405914

### TP, TPE Series 300

Pump type	Hexagon head screws	Product number
TP, TPE 32 TP, TPE 40 TP, TPE 50 TP, TPE 65 TP, TPE 80-xx/2 TP, TPE 80-70/4 TP, TPE 80-90/4 TP, TPE 80-110/4 TP, TPE 80-150/4 TP, TPE 80-170/4 TP, TPE 100-160/2 TP, TPE 100-200/2 TP, TPE 100-240/2	2 x M16 x 30 mm	00485031

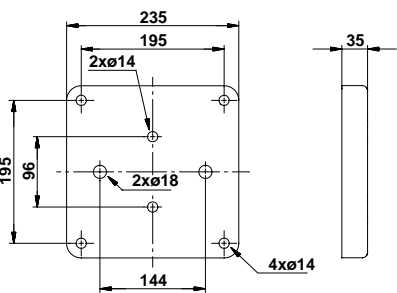
Drawing	Product number
	00485031

### TP, TPE Series 300

Pump type	Hexagon head screws	Product number
TP, TPE 80-240/4 TP, TPE 80-270/4 TP, TPE 80-340/4 TP, TPE 100-250/2 TP, TPE 100-310/2 TP, TPE 100-360/2 TP, TPE 100-390/2 TP, TPE 100-480/2 TP, TPE 100-xx/4 TP, TPE 125-xx/4 TP, TPE 150-xx/4 TP, TPE 125-xx/6 TP, TPE 150-xx/6	2 x M16 x 30 mm	96536246

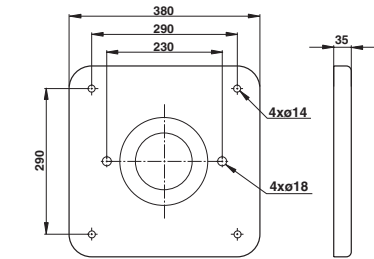
Drawing	Product number
	96536246

### TPD, TPED Series 300

Pump type	Hexagon head screws	Product number
TPD, TPED 32 TPD, TPED 40 TPD, TPED 50 TPD, TPED 65 TPD, TPED 80-xx/2 TPD, TPED 80-70/4 TPD, TPED 80-90/4 TPD, TPED 80-110/4 TPD, TPED 80-150/4 TPD, TPED 80-170/4 TPD, TPED 100-160/2 TPD, TPED 100-200/2 TPD, TPED 100-240/2	4 x M16 x 30 mm	96489381

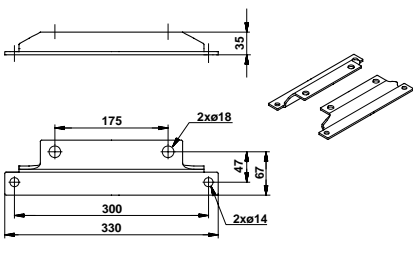
Drawing	Product number
	96489381

## TPD, TPED Series 300

Pump type	Hexagon head screws	Product number
TPD, TPED 100-250/2 TPD, TPED 100-310/2 TPD, TPED 100-360/2 TPD, TPED 100-390/2 TPD, TPED 100-70/4 TPD, TPED 100-90/4 TPD, TPED 100-110/4 TPD, TPED 100-130/4 TPD, TPED 100-170/4	4 x M16 x 30 mm	96536247

Drawing	Product number
---------	----------------

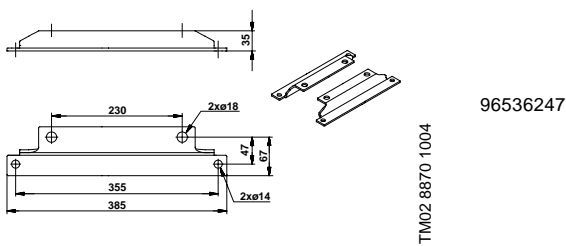

## TPD, TPED Series 300

Pump type	Hexagon head screws	Product number
TPD, TPED 80-240/4 TPD, TPED 80-270/4 TPD, TPED 80-340/4 TPD, TPED 100-200/4 TPD, TPED 100-250/4 TPD, TPED 100-330/4 TPD, TPED 100-370/4 TPD, TPED 100-410/4 TPD, TPED 125-xx/4 TPD, TPED 150-xx/4	4 x M16 x 30 mm	96536248

Drawing	Product number
---------	----------------

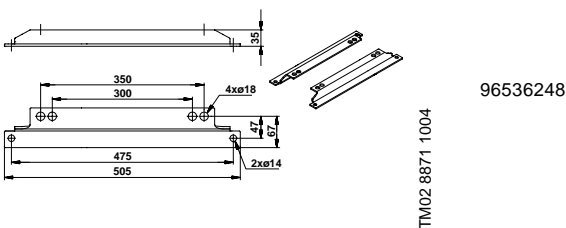

## Blanking flanges

Normally used with twin-head pumps.

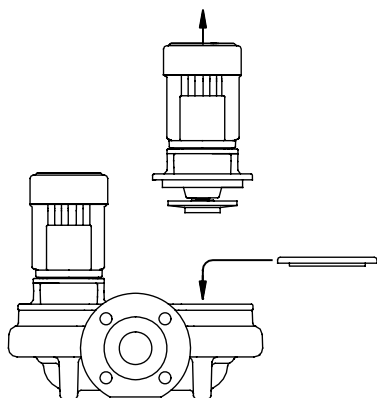

TM00 6360 3495

### TPD, TPED 2-pole

Pump type	00545048	00565055	96495694	96495695	96495696	96525962	96525963	96525964
TPD, TPED 32-60/2	•							
TPD, TPED 32-120/2	•							
TPD, TPED 32-150/2		•						
TPD, TPED 32-180/2		•						
TPD, TPED 32-230/2		•						
TPD, TPED 32-200/2			•					
TPD, TPED 32-250/2			•					
TPD, TPED 32-320/2			•					
TPD, TPED 32-380/2			•					
TPD, TPED 32-460/2				•				
TPD, TPED 32-580/2				•				
TPD, TPED 40-60/2	•							
TPD, TPED 40-120/2	•							
TPD, TPED 40-190/2		•						
TPD, TPED 40-230/2		•						
TPD, TPED 40-270/2		•						
TPD, TPED 40-240/2			•					
TPD, TPED 40-300/2			•					
TPD, TPED 40-360/2			•					
TPD, TPED 40-470/2				•				
TPD, TPED 40-580/2				•				
TPD, TPED 50-60/2	•							
TPD, TPED 50-120/2		•						
TPD, TPED 50-180/2		•						
TPD, TPED 50-160/2			•					
TPD, TPED 50-190/2			•					
TPD, TPED 50-240/2			•					
TPD, TPED 50-290/2			•					
TPD, TPED 50-360/2			•					
TPD, TPED 50-430/2			•					
TPD, TPED 50-440/2					•			
TPD, TPED 50-570/2					•			
TPD, TPED 50-710/2					•			
TPD, TPED 50-830/2					•			
TPD, TPED 50-900/2					•			

# Accessories

TP, TPD, TPE, TPED

Pump type	00545048	00565055	96495694	96495695	96495696	96525962	96525963	96525964
TPD, TPED 65-60/2	•							
TPD, TPED 65-120/2		•						
TP, TPD 65-180/2		•						
TPD, TPED 65-190/2			•					
TPD, TPED 65-230/2			•					
TPD, TPED 65-260/2			•					
TPD, TPED 65-340/2			•					
TPD, TPED 65-410/2			•					
TPD, TPED 65-340/2			•					
TPD, TPED 65-410/2			•					
TPD, TPED 65-460/2					•			
TPD, TPED 65-550/2					•			
TPD, TPED 65-660/2					•			
TPD, TPED 65-720/2					•			
TPD 65-930/2					•			
TPD, TPED 80-120/2		•						
TPD, TPED 80-140/2			•					
TPD, TPED 80-180/2			•					
TPD, TPED 80-210/2			•					
TPD, TPED 80-240/2			•					
TPD, TPED 80-250/2			•					
TPD, TPED 80-330/2			•					
TPD, TPED 80-400/2			•					
TPD, TPED 80-520/2				•				
TPD, TPED 80-570/2				•				
TP, TPD 80-700/2				•				
TPD, TPED 100-120/2		•						
TPD, TPED 100-160/2			•					
TPD, TPED 100-200/2			•					
TPD, TPED 100-240/2			•					
TPD, TPED 100-250/2			•					
TPD, TPED 100-310/2			•					
TPD, TPED 100-360/2			•					
TPD, TPED 100-390/2			•					
TP, TPD 100-480/2						•		

## TPD, TPED 4-pole

Pump type	00545048	00565055	96495694	96495695	96495696	96525962	96525963	96525964
TPD, TPED 32-30/4	•							
TPD, TPED 32-40/4	•							
TPD, TPED 32-60/4		•						
TPD, TPED 32-80/4			•					
TPD, TPED 32-100/4			•					
TPD, TPED 32-120/4				•				
TPD, TPED 40-30/4	•							
TPD, TPED 40-90/4		•						
TPD, TPED 40-100/4			•					
TPD, TPED 40-130/4				•				
TPD, TPED 40-160/4				•				
TPD, TPED 50-30/4	•							
TPD, TPED 50-60/4		•						
TPD, TPED 50-90/4			•					
TPD, TPED 50-110/4					•			
TPD, TPED 50-130/4					•			
TPD, TPED 50-160/4					•			
TPD, TPED 50-190/4					•			
TPD, TPED 50-230/4					•			
TPD, TPED 65-30/4		•						
TPD, TPED 65-60/4		•						
TPD, TPED 65-90/4			•					
TPD, TPED 65-110/4					•			
TPD, TPED 65-130/4					•			
TPD, TPED 65-150/4					•			
TPD, TPED 65-170/4					•			
TPD, TPED 65-240/4					•			
TPD, TPED 80-30/4		•						
TPD, TPED 80-60/4		•						
TPD, TPED 80-70/4			•	•				
TPD, TPED 80-90/4			•					
TPD, TPED 80-110/4			•					
TPD, TPED 80-150/4				•				
TPD, TPED 80-170/4				•				
TPD, TPED 80-240/4								•
TPD, TPED 80-270/4								•
TPD, TPED 80-340/4								•
TPD, TPED 100-30/4		•						
TPD, TPED 100-60/4		•						
TPD, TPED 100-70/4			•					
TPD, TPED 100-90/4			•					
TPD, TPED 100-110/4			•					
TPD, TPED 100-130/4						•		
TPD, TPED 100-170/4						•		
TPD, TPED 100-200/4								•
TPD, TPED 100-250/4								•
TPD, TPED 100-330/4								•
TPD, TPED 100-370/4								•
TPD, TPED 100-410/4								•
TPD, TPED 125-110/4						•		
TPD, TPED 125-130/4						•		
TPD, TPED 125-160/4						•		
TPD, TPED 125-210/4								•
TPD, TPED 125-250/4								•
TPD, TPED 125-320/4								•
TPD, TPED 125-360/4								•
TPD 125-420/4								•

Pump type	00545048	00565055	96495694	96495695	96495696	96525962	96525963	96525964
TPD, TPED 150-130/4							•	
TPD, TPED 150-160/4							•	
TPD, TPED 150-200/4							•	
TPD, TPED 150-220/4							•	
TPD, TPED 150-250/4							•	

## TPD 6-pole

Pump type	00545048	00565055	96495694	96495695	96495696	96525962	96525963	96525964
TP, TPD 125-60/6						•		
TP, TPD 125-70/6						•		
TP, TPD 125-90/6								•
TP, TPD 125-110/6								•
TP, TPD 125-140/6								•
TP, TPD 125-170/6								•
TP, TPD 150-60/6							•	
TP, TPD 150-70/6							•	
TP, TPD 150-90/6							•	
TPD 150-110/6							•	

## Insulating kits

Insulating kits are only available for TP, TPE Series 200 pumps. An insulating kit consists of two or three insulating covers made of expanded polypropylene (EPP).

The insulating kit is tailored to the individual pump model and has an insulating thickness corresponding to the nominal diameter of the pump.

The thermal conductivity of EPP is very low (0.04 W/m °C), i.e. the insulating property is very good.

The insulating kit encloses the entire pump housing.

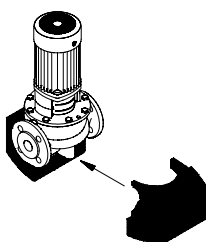

Fig. 38 Insulating kit

TM00 8035 2496

## Product numbers of insulating kits

Single-head TP, TPE Series 200 pumps	
Pump type	Product number
TP, TPE 32-30/4	96405871
TP, TPE 32-40/4	96405880
TP, TPE 32-60/2	96405873
TP, TPE 32-60/4	96405880
TP, TPE 32-120/2	96405873
TP, TPE 32-150/2	96405880
TP, TPE 32-180/2	96405880
TP, TPE 32-230/2	96405880
TP, TPE 40-30/4	96405874
TP, TPE 40-60/4	96405875
TP, TPE 40-60/2	96405876
TP, TPE 40-90/4	96405880
TP, TPE 40-120/2	96405877
TP, TPE 40-180/2	96405878
TP, TPE 40-190/2	96405880
TP, TPE 40-230/2	96405880
TP, TPE 40-270/2	96405880
TP, TPE 50-30/4	96405879
TP, TPE 50-60/2	96405881
TP, TPE 50-60/4	96405880
TP, TPE 50-120/2	96405882
TP, TPE 50-180/2	96405883
TP, TPE 65-30/4	96405884
TP, TPE 65-60/2	96405886
TP, TPE 65-60/4	96405885
TP, TPE 65-120/2	96405887
TP, TPE 65-180/2	96405888
TP, TPE 80-30/4	96405889
TP, TPE 80-60/4	96405890
TP, TPE 80-120/2	96405891
TP, TPE 100-30/4	96405892
TP, TPE 100-60/4	96405892

## Sensors

Accessory	Type	Supplier	Measuring range	Product number
Flowmeter	SITRANS F M MAGFLO MAG 3100/5000 W	Siemens	1-5 m <sup>3</sup> /h (DN 25)	ID8285
Flowmeter	SITRANS F M MAGFLO MAG 3100/5000 W	Siemens	3-10 m <sup>3</sup> /h (DN 40)	ID8286
Flowmeter	SITRANS F M MAGFLO MAG 3100/5000 W	Siemens	6-30 m <sup>3</sup> /h DN 65)	ID8287
Flowmeter	SITRANS F M MAGFLO MAG 3100/5000 W	Siemens	20-75 m <sup>3</sup> /h (DN 100)	ID8288
Temperature sensor	TTA (0) 25	Carlo Gavazzi	0 °C to +25 °C	96432591
Temperature sensor	TTA (-25) 25	Carlo Gavazzi	-25 °C to +25 °C	96430194
Temperature sensor	TTA (50) 100	Carlo Gavazzi	50 °C to +100 °C	96432592
Temperature sensor	TTA (0) 150	Carlo Gavazzi	0 °C to +150 °C	96430195
Accessory for temperature sensor. All with ½ RG connection.	Protecting tube ∅9 x 50 mm	Carlo Gavazzi		96430201
	Protecting tube ∅9 x 100 mm	Carlo Gavazzi		96430202
	Cutting ring bush	Carlo Gavazzi		96430203
Temperature sensor, ambient temperature	WR 52	tmg (DK: Plesner)	-50 °C to +50 °C	ID8295
Differential temperature sensor	ETSD	Honsberg	0 °C to +20 °C	96409362
Differential temperature sensor	ETSD	Honsberg	0 °C to +50 °C	96409363

**Note:** All sensors have 4-20 mA output signal.

### Sensors for boosting applications

Danfoss pressure sensor kit	Pressure range	Product number
<ul style="list-style-type: none"> <li>• Connection: G 1/2 A (DIN 16288 - B6kt)</li> <li>• Electrical connection: plug (DIN 43650)</li> </ul>	0 - 2.5 bar	96478188
	0 - 4 bar	91072075
	0 - 6 bar	91072076
	0 - 10 bar	91072077
	0 - 16 bar	91072078
<ul style="list-style-type: none"> <li>• Pressure sensor, type MBS 3000, with 2 m screened cable</li> <li>• Connection: G 1/4 A (DIN 16288 - B6kt)</li> <li>• 5 cable clips (black)</li> <li>• Fitting instructions PT (00400212)</li> </ul>	0 - 2.5 bar	405159
	0 - 4 bar	405160
	0 - 6 bar	405161
	0 - 10 bar	405162
	0 - 16 bar	405163

### Sensors for circulation applications

Grundfos differential pressure sensor, DPI	Pressure range	Product number
<ul style="list-style-type: none"> <li>• 1 sensor incl. 0.9 m screened cable (7/16" connections)</li> <li>• 1 original DPI bracket (for wall mounting)</li> <li>• 1 Grundfos bracket (for mounting on motor)</li> <li>• 2 M4 screws for mounting of sensor on bracket</li> <li>• 1 M6 screw (self-cutting) for mounting on MGE 90/100</li> <li>• 1 M8 screw (self-cutting) for mounting on MGE 112/132</li> <li>• 1 M10 screw (self-cutting) for mounting on MGE 160</li> <li>• 1 M12 screw (self-cutting) for mounting on MGE 180</li> <li>• 3 capillary tubes (short/long)</li> <li>• 2 fittings (1/4" - 7/16")</li> <li>• 5 cable clips (black)</li> <li>• Installation and operating instructions</li> <li>• Service kit instruction</li> </ul>	0 - 0.6 bar	96611522
	0 - 1.0 bar	96611523
	0 - 1.6 bar	96611524
	0 - 2.5 bar	96611525
	0 - 4.0 bar	96611526
	0 - 6.0 bar	96611527
	0 - 10 bar	96611550
Fitting kit for TPED with two sensors		96491010

Select the differential pressure sensor so that the maximum pressure of the sensor is higher than the maximum differential pressure of the pump.

## Potentiometer

Potentiometer for setpoint setting and start/stop of the pump.

Product	Product number
External potentiometer with cabinet for wall mounting.	625468

## R100

R100 is used for wireless communication. Communication takes place by means of infrared light.

Product	Product number
R100	625333

## CIU communication interface units



GrA 6118

Fig. 39 Grundfos CIU communication interface unit

The CIU units enable communication of operating data, such as measured values and setpoints, between TPE pumps and a building management system. The CIU unit incorporates a 24-240 VAC/VDC power supply module and a CIM module. It can either be mounted on a DIN rail or on a wall.

We offer the following CIU units:

### CIU 100

For communication via LON.

### CIU 150

For communication via PROFIBUS DP.

### CIU 200

For communication via Modbus RTU.

### CIU 300

For communication via BACnet MS/TP.

Description	Fieldbus protocol	Product number
CIU 100	LON	96753735
CIU 150	PROFIBUS DP	96753081
CIU 200	Modbus RTU	96753082
CIU 300	BACnet MS/TP	Contact Grundfos

For further information about data communication via CIU units and fieldbus protocols, see the CIU documentation available in WebCAPS.

## CIM communication interface modules

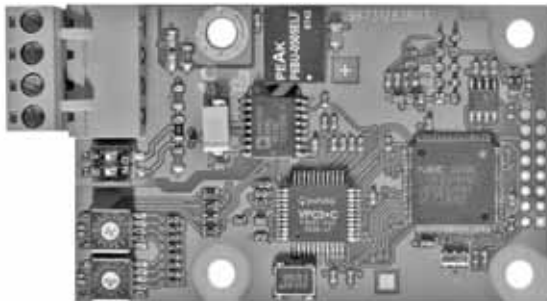

GFA6121

**Fig. 40** Grundfos CIM communication interface module

The CIM modules enable communication of operating data, such as measured values and setpoints, between TPE pumps of 11-22 kW and a building management system. The CIM modules are add-on communication modules which are installed in the terminal box of TPE pumps of 11-22 kW.

**Note:** CIM modules must be installed by authorised personnel.

We offer the following CIM modules:

### CIM 100

For communication via LON.

### CIM 150

For communication via PROFIBUS DP.

### CIM 200

For communication via Modbus RTU.

### CIM 300

For communication via BACnet MS/TP.

Description	Fieldbus protocol	Product number
CIM 100	LON	96824797
CIM 150	PROFIBUS DP	96824793
CIM 200	Modbus RTU	96824796
CIM 300	BACnet MS/TP	Contact Grundfos

For further information about data communication via CIM modules and fieldbus protocols, see the CIM documentation available in WebCAPS.

## EMC filter

### EMC (electromagnetic compatibility to EN 61800-3)

Motor [kW]		Emission/immunity
2-pole	4-pole	
0.37	0.37	
0.55	0.55	
0.75	0.75	
1.1	1.1	<b>Emission:</b>
1.5	1.5	Motors may be installed in <b>residential areas</b> (first environment), unrestricted distribution, corresponding to CISPR11, group 1, class B.
2.2	2.2	
3.0	3.0	<b>Immunity:</b>
4.0	4.0	Motors fulfil the requirements for both the first and second environment.
5.5	–	
7.5	–	
–	5.5	
–	7.5	<b>Emission:</b>
11	11	The motors are category C3, corresponding to CISPR11, group 2, class A, and may be installed in <b>industrial areas</b> (second environment).
15	15	
18.5	18.5	If equipped with an external Grundfos EMC filter, the motors are category C2, corresponding to CISPR11, group 1, class A, and may be installed in <b>residential areas</b> (first environment).
22	–	



TM02 9198 1203

**Fig. 41** EMC filter

The EMC filter for residential areas is available as a complete kit ready for installation.

Product	Product number
EMC-filter (TPE 5.5 kW and 7.5 kW, 4-pole)	96041047
EMC-filter (TPE 11-22 kW)	96478309

To ensure optimum and noiseless operation we recommend the minimum inlet pressure values shown on page 138 to 140.

A minimum inlet pressure is required to avoid pressure drop that may cause cavitation.

The minimum inlet pressure ( $p_s$ ) in bar relative (pressure gauge value on the pump suction side) can be calculated using the following formula.

**Note:** Calculation of the minimum inlet pressure should be based on the maximum required flow.

$$p_s \geq \left( (NPSH_R + H_s) \times \rho \times g - \left( \frac{1}{2} \times \rho \times c^2 \right) \right) \times 0.00001 - p_b + p_d \quad [\text{bar relative}]$$

- $p_s$  = Minimum inlet pressure in bar.
- $NPSH_R$  = The required Net Positive Suction Head in metres head.  
(To be read from the NPSH curve at the highest flow the pump will be delivering).
- $H_s$  = Safety margin = minimum 0.5 metres head.  
**Note:** A safety margin of 0.5 metres prevents pressure drop.
- $\rho$  = Density of the pumped liquid measured in  $\text{kg/m}^3$ .
- $g$  = Gravitational acceleration measured in  $\text{m/s}$ . For estimated calculations use the value  $9.81 \text{ m/s}^2$ .
- $c$  = Flow velocity of the pumped liquid at the pressure gauge. Insert the flow velocity as the unit  $[\text{m/s}]$ .  
(See individual curve charts from page 48).
- $p_b$  = Barometric pressure in bar.  
(Set the barometric pressure to 0.97 bar)  
**Note:** Only occasionally is the pressure as high as 1 bar; also this value is at sea level.
- $p_d$  = Vapour pressure in bar. (See fig. 42).

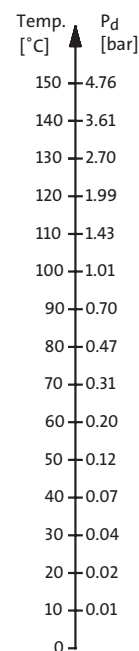
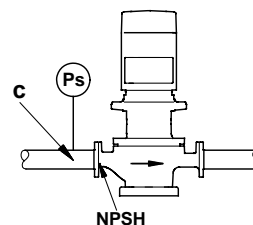

Fig. 42 Minimum inlet pressure

TM02 8491 0204 - TM03 0371 5004

# Minimum inlet pressure - NPSH

TP, TPD, TPE, TPED

## TP, TPD 2-pole, PN 6, 10, 16

Pump type	p [bar]					
	20 °C	60 °C	90 °C	110 °C	120 °C	140 °C
TP 25-50/2 R	0.1	0.1	0.1	0.8	1.4	3.1
TP 25-90/2 R	0.1	0.1	0.1	0.8	1.4	3.1
TP 32-50/2 R	0.1	0.1	0.1	0.8	1.4	3.1
TP 32-90/2 R	0.1	0.1	0.1	0.8	1.4	3.1
TP, TPD 32-60/2	0.1	0.1	0.2	1.0	1.5	3.2
TP, TPD 32-120/2	0.1	0.2	0.7	1.5	2.0	3.7
TP, TPD 32-150/2	0.1	0.3	0.8	1.6	2.1	3.8
TP, TPD 32-180/2	0.5	0.7	1.2	2.0	2.5	4.2
TP, TPD 32-230/2	0.7	0.9	1.4	2.2	2.7	4.4
TP, TPD 32-200/2	0.1	0.1	0.2	0.9	1.5	3.1
TP, TPD 32-250/2	0.1	0.1	0.3	1.0	1.6	3.2
TP, TPD 32-320/2	0.1	0.1	0.6	1.3	1.9	3.5
TP, TPD 32-380/2	0.1	0.2	0.7	1.4	2.0	3.6
TP, TPD 32-460/2	0.1	0.2	0.7	1.4	1.9	3.6
TP, TPD 32-580/2	0.2	0.4	0.9	1.6	2.2	3.8
TP 40-50/2	0.1	0.1	0.1	0.8	1.4	3.1
TP, TPD 40-60/2	0.1	0.1	0.5	1.2	1.8	3.5
TP 40-90/2	0.1	0.1	0.1	0.8	1.4	3.1
TP, TPD 40-120/2	0.1	0.1	0.4	1.2	1.7	3.4
TP 40-180/2	0.1	0.2	0.7	1.5	2.0	3.7
TP, TPD 40-190/2	0.1	0.3	0.8	1.6	2.1	3.8
TP, TPD 40-230/2	0.7	0.9	1.4	2.2	2.7	4.4
TP, TPD 40-270/2	0.7	0.9	1.4	2.2	2.7	4.4
TP, TPD 40-240/2	0.1	0.1	0.4	1.1	1.7	3.3
TP, TPD 40-300/2	0.1	0.1	0.4	1.1	1.6	3.3
TP, TPD 40-360/2	0.2	0.4	0.9	1.6	2.1	3.8
TP, TPD 40-470/2	0.1	0.1	0.4	1.1	1.6	3.3
TP, TPD 40-580/2	0.2	0.4	0.9	1.6	2.1	3.8
TP, TPD 50-60/2	0.1	0.1	0.4	1.1	1.7	3.4
TP, TPD 50-120/2	0.1	0.2	0.7	1.5	2.0	3.7
TP, TPD 50-180/2	0.1	0.2	0.7	1.4	2.0	3.7
TP, TPD 50-160/2	0.1	0.1	0.1	0.8	1.4	3.0
TP, TPD 50-190/2	0.1	0.1	0.1	0.9	1.4	3.0
TP, TPD 50-240/2	0.1	0.1	0.1	0.8	1.4	3.0
TP, TPD 50-290/2	0.1	0.1	0.2	0.9	1.5	3.1
TP, TPD 50-360/2	0.1	0.1	0.2	1.0	1.5	3.1
TP, TPD 50-430/2	0.1	0.1	0.4	1.1	1.6	3.2
TP, TPD 50-440/2	0.1	0.1	0.4	1.1	1.6	3.3
TP, TPD 50-570/2	0.1	0.3	0.8	1.6	2.1	3.7
TP, TPD 50-710/2	0.6	0.8	1.3	2.0	2.6	4.2
TP, TPD 50-830/2	0.5	0.7	1.2	2.0	2.5	4.1
TP, TPD 50-900/2	1.0	1.2	1.7	2.4	3.0	4.6
TP, TPD 65-60/2	0.1	0.3	0.8	1.5	2.1	3.8
TP, TPD 65-120/2	0.5	0.7	1.2	2.0	2.5	4.2
TP, TPD 65-180/2	0.3	0.5	1.0	1.8	2.3	4.0
TP, TPD 65-190/2	0.1	0.1	0.1	0.7	1.3	2.9
TP, TPD 65-230/2	0.1	0.1	0.1	0.8	1.4	3.0
TP, TPD 65-260/2	0.1	0.1	0.1	0.8	1.4	3.0
TP, TPD 65-340/2	0.1	0.1	0.2	0.9	1.4	3.1
TP, TPD 65-410/2	0.1	0.1	0.2	0.9	1.4	3.1
TP, TPD 65-460/2	0.1	0.1	0.2	1.0	1.5	3.1
TP, TPD 65-550/2	0.1	0.1	0.3	1.0	1.6	3.2
TP, TPD 65-660/2	0.1	0.1	0.4	1.1	1.6	3.3
TP, TPD 65-720/2	0.1	0.1	0.6	1.3	1.9	3.5
TP, TPD 65-930/2	0.6	0.8	1.3	2.0	2.6	4.2

Pump type	p [bar]					
	20 °C	60 °C	90 °C	110 °C	120 °C	140 °C
TP, TPD 80-120/2	1.2	1.4	1.9	2.7	3.2	4.9
TP, TPD 80-140/2	0.1	0.2	0.7	1.4	1.9	3.6
TP, TPD 80-180/2	0.1	0.1	0.3	1.1	1.6	3.2
TP, TPD 80-210/2	0.1	0.1	0.4	1.1	1.7	3.3
TP, TPD 80-240/2	0.1	0.1	0.6	1.3	1.8	3.5
TP, TPD 80-250/2	0.1	0.3	0.8	1.6	2.1	3.7
TP, TPD 80-330/2	0.1	0.2	0.7	1.4	2.0	3.6
TP, TPD 80-400/2	0.2	0.4	0.9	1.7	2.2	3.8
TP, TPD 80-520/2	0.1	0.2	0.7	1.4	1.9	3.6
TP, TPD 80-570/2	0.1	0.3	0.8	1.6	2.1	3.7
TP, TPD 80-700/2	0.6	0.8	1.3	2.1	2.6	4.2
TP, TPD 100-120/2	1.9	2.1	2.6	3.4	3.9	5.6
TP, TPD 100-160/2	0.1	0.1	0.6	1.3	1.9	3.5
TP, TPD 100-200/2	0.1	0.1	0.4	1.2	1.7	3.3
TP, TPD 100-240/2	0.1	0.1	0.5	1.3	1.8	3.4
TP, TPD 100-250/2	0.6	0.8	1.3	2.0	2.5	4.2
TP, TPD 100-310/2	0.6	0.8	1.3	2.0	2.6	4.2
TP, TPD 100-360/2	0.6	0.8	1.3	2.0	2.6	4.2
TP, TPD 100-390/2	1.0	1.2	1.7	2.4	3.0	4.6
TP, TPD 100-480/2	1.5	1.7	2.2	2.9	3.5	5.1

# Minimum inlet pressure - NPSH

TP, TPD, TPE, TPED

## TP, TPD 4-pole, PN 6, 10, 16

Pump type	p [bar]					
	20 °C	60 °C	90 °C	110 °C	120 °C	140 °C
TP, TPD 32-30/4	0.1	0.1	0.1	0.8	1.4	3.1
TP, TPD 32-40/4	0.1	0.1	0.1	0.9	1.4	3.1
TP, TPD 32-60/4	0.1	0.1	0.3	1.1	1.6	3.3
TP, TPD 32-80/4	0.1	0.1	0.1	0.5	1.1	2.7
TP, TPD 32-100/4	0.1	0.1	0.1	0.5	1.1	2.7
TP, TPD 32-120/4	0.1	0.1	0.1	0.6	1.1	2.7
TP, TPD 40-30/4	0.1	0.1	0.2	0.9	1.5	3.2
TP 40-60/4	0.1	0.1	0.1	0.8	1.4	3.1
TP, TPD 40-90/4	0.1	0.1	0.3	1.0	1.6	3.3
TP, TPD 40-100/4	0.1	0.1	0.2	0.9	1.5	3.1
TP, TPD 40-130/4	0.1	0.1	0.1	0.7	1.2	2.8
TP, TPD 40-160/4	0.1	0.1	0.2	0.9	1.5	3.1
TP, TPD 50-30/4	0.1	0.1	0.1	0.9	1.4	3.1
TP, TPD 50-60/4	0.1	0.1	0.2	0.9	1.5	3.2
TP, TPD 50-90/4	0.1	0.1	0.1	0.6	1.4	2.8
TP, TPD 50-110/4	0.1	0.1	0.1	0.6	1.4	2.8
TP, TPD 50-130/4	0.1	0.1	0.1	0.6	1.2	2.8
TP, TPD 50-160/4	0.1	0.1	0.1	0.7	1.3	2.9
TP, TPD 50-190/4	0.1	0.1	0.1	0.9	1.4	3.0
TP, TPD 50-230/4	0.1	0.1	0.1	1.0	1.5	3.2
TP, TPD 65-30/4	0.1	0.2	0.7	1.5	2.0	3.7
TP, TPD 65-60/4	0.2	0.4	0.9	1.6	2.2	3.9
TP, TPD 65-90/4	0.1	0.1	0.1	0.6	1.1	2.7
TP, TPD 65-110/4	0.1	0.1	0.1	0.6	1.1	2.7
TP, TPD 65-130/4	0.1	0.1	0.1	0.6	1.1	2.8
TP, TPD 65-150/4	0.1	0.1	0.1	0.6	1.2	2.8
TP, TPD 65-170/4	0.1	0.1	0.1	0.6	1.2	2.8
TP, TPD 65-240/4	0.1	0.1	0.1	0.8	1.3	2.9
TP, TPD 80-30/4	0.8	1.0	1.5	2.2	2.8	4.5
TP, TPD 80-60/4	0.8	1.0	1.5	2.3	2.8	4.5
TP, TPD 80-70/4	0.1	0.1	0.1	0.8	1.3	2.9
TP, TPD 80-90/4	0.1	0.1	0.1	0.7	1.2	2.8
TP, TPD 80-110/4	0.1	0.1	0.1	0.8	1.4	3.0
TP, TPD 80-150/4	0.1	0.1	0.1	0.8	1.3	3.0
TP, TPD 80-170/4	0.1	0.1	0.2	1.0	1.5	3.1
TP, TPD 80-240/4	0.1	0.1	0.3	1.0	1.5	3.2
TP, TPD 80-270/4	0.1	0.1	0.2	0.9	1.5	3.1
TP, TPD 80-340/4	0.1	0.1	0.3	1.1	1.6	3.2
TP, TPD 100-30/4	0.8	1.0	1.5	2.2	2.8	4.5
TP, TPD 100-60/4	0.6	0.8	1.3	2.0	2.6	4.3
TP, TPD 100-70/4	0.1	0.1	0.1	0.8	1.3	3.0
TP, TPD 100-90/4	0.1	0.1	0.1	0.9	1.4	3.0
TP, TPD 100-110/4	0.1	0.1	0.2	1.0	1.5	3.1
TP, TPD 100-130/4	0.1	0.1	0.6	1.3	1.9	3.5
TP, TPD 100-170/4	0.3	0.5	1.0	1.7	2.3	3.9
TP, TPD 100-200/4	0.1	0.1	0.5	1.2	1.8	3.4
TP, TPD 100-250/4	0.1	0.2	0.7	1.4	2.0	3.6
TP, TPD 100-330/4	0.3	0.5	1.0	1.7	2.3	3.9
TP, TPD 100-370/4	0.3	0.5	1.0	1.7	2.3	3.9
TP, TPD 100-410/4	0.5	0.7	1.2	1.9	2.5	4.1
TP, TPD 125-110/4	0.1	0.1	0.1	0.9	1.4	3.0
TP, TPD 125-130/4	0.1	0.1	0.2	0.9	1.5	3.1
TP, TPD 125-160/4	0.1	0.1	0.3	1.0	1.5	3.2
TP, TPD 125-210/4	0.1	0.1	0.3	1.0	1.6	3.2
TP, TPD 125-250/4	0.1	0.1	0.4	1.1	1.7	3.3
TP, TPD 125-320/4	0.1	0.1	0.3	1.0	1.6	3.2
TP, TPD 125-360/4	0.1	0.1	0.4	1.2	1.7	3.3

Pump type	p [bar]					
	20 °C	60 °C	90 °C	110 °C	120 °C	140 °C
TP, TPD 125-420/4	0.1	0.2	0.7	1.4	2.0	3.6
TP, TPD 150-130/4	0.1	0.1	0.4	1.1	1.6	3.3
TP, TPD 150-160/4	0.1	0.1	0.4	1.1	1.7	3.3
TP, TPD 150-200/4	0.1	0.1	0.4	1.1	1.7	3.3
TP, TPD 150-220/4	0.1	0.1	0.5	1.2	1.8	3.4
TP, TPD 150-250/4	0.1	0.1	0.6	1.3	1.9	3.5
TP 150-260/4	0.6	0.8	1.3	2.0	2.5	4.2
TP 150-280/4	0.6	0.8	1.3	2.1	2.6	4.2
TP 150-340/4	0.9	1.1	1.6	2.3	2.9	4.5
TP 150-390/4	2.0	2.2	2.7	3.5	4.0	5.6
TP 200-180/4	1.4	1.6	2.1	2.8	3.3	5.0
TP 200-220/4	1.1	1.3	1.8	2.6	3.1	4.7
TP 200-250/4	1.1	1.3	1.8	2.5	3.1	4.7
TP 200-270/4	1.6	1.8	2.3	3.0	3.6	5.2
TP 200-320/4	1.6	1.8	2.3	3.1	3.4	5.2
TP 200-330/4	1.1	1.3	1.8	2.5	3.1	4.7
TP 200-360/4	1.2	1.4	1.9	2.6	3.1	4.8
TP 200-400/4	1.3	1.5	2.0	2.8	3.3	4.9
TP 200-410/4	2.3	2.5	3.0	3.7	4.3	5.9
TP 200-470/4	1.4	1.6	2.1	2.8	3.4	5.0
TP 200-530/4	1.6	1.8	2.3	3.0	3.6	5.2
TP 200-590/4	1.7	1.9	2.4	3.2	3.7	5.3
TP 200-660/4	2.9	3.1	3.6	4.3	4.9	6.5
TP 250-280/4	0.1	0.1	0.1	0.8	1.4	3.1
TP 250-310/4	0.1	0.1	0.1	0.8	1.4	3.1
TP 250-390/4	0.1	0.1	0.1	0.8	1.4	3.1

## TP, TPD 6-pole, PN 16

Pump type	p [bar]					
	20 °C	60 °C	90 °C	110 °C	120 °C	140 °C
TP, TPD 125-60/6	0.1	0.1	0.1	0.7	1.2	2.8
TP, TPD 125-70/6	0.1	0.1	0.1	0.7	1.3	2.9
TP, TPD 125-90/6	0.1	0.1	0.1	0.7	1.2	2.9
TP, TPD 125-110/6	0.1	0.1	0.1	0.8	1.3	2.9
TP, TPD 125-140/6	0.1	0.1	0.1	0.7	1.3	2.9
TP, TPD 125-170/6	0.1	0.1	0.1	0.8	1.4	3.0
TP, TPD 150-60/6	0.1	0.1	0.1	0.7	1.3	2.9
TP, TPD 150-70/6	0.1	0.1	0.1	0.7	1.3	2.9
TP, TPD 150-90/6	0.1	0.1	0.1	0.8	1.3	2.9
TP, TPD 150-110/6	0.1	0.1	0.1	0.8	1.3	3.0

## TP Series 400, 2-pole, PN 25

Pump type	p [bar]					
	20 °C	60 °C	90 °C	110 °C	120 °C	140 °C
TP 100-620/2	0.2	0.4	0.9	1.6	2.2	3.9
TP 100-700/2	0.1	0.2	0.7	1.5	2.0	3.7
TP 100-820/2	0.1	0.2	0.7	1.4	2.0	3.7
TP 100-960/2	0.1	0.2	0.7	1.4	2.0	3.7
TP 100-1050/2	0.1	0.1	0.6	1.3	1.9	3.6
TP 100-1180/2	0.1	0.2	0.7	1.5	2.0	3.7
TP 100-1400/2	0.1	0.2	0.7	1.5	2.0	3.7
TP 100-1530/2	0.1	0.2	0.7	1.4	2.0	3.7
TP 100-1680/2	0.1	0.1	0.6	1.4	1.9	3.6

## TP Series 400, 4-pole, PN 25

Pump type	p [bar]					
	20 °C	60 °C	90 °C	110 °C	120 °C	140 °C
TP 100-190/4	0.1	0.1	0.1	0.8	1.4	3.1
TP 100-220/4	0.1	0.1	0.1	0.8	1.4	3.1
TP 100-260/4	0.1	0.1	0.1	0.8	1.4	3.1
TP 100-270/4	0.1	0.1	0.1	0.8	1.4	3.1
TP 100-320/4	0.1	0.1	0.1	0.8	1.4	3.1
TP 100-380/4	0.1	0.1	0.1	0.8	1.4	3.1
TP 100-420/4	0.1	0.1	0.1	0.8	1.4	3.1
TP 125-150/4	0.1	0.1	0.1	0.8	1.4	3.1
TP 125-200/4	0.1	0.1	0.1	0.8	1.4	3.1
TP 125-240/4	0.1	0.1	0.1	0.8	1.4	3.1
TP 125-280/4	0.1	0.1	0.1	0.8	1.4	3.1
TP 125-310/4	0.1	0.1	0.1	0.8	1.4	3.1
TP 125-370/4	0.1	0.1	0.1	0.8	1.4	3.1
TP 125-430/4	0.1	0.1	0.1	0.8	1.4	3.1
TP 150-240/4	0.1	0.1	0.1	0.8	1.4	3.1
TP 150-270/4	0.1	0.1	0.1	0.8	1.4	3.1
TP 150-320/4	0.1	0.1	0.1	0.8	1.4	3.1
TP 150-350/4	0.1	0.1	0.1	0.8	1.4	3.1
TP 150-430/4	0.1	0.1	0.1	0.8	1.4	3.1
TP 150-530/4	0.1	0.1	0.1	0.8	1.4	3.1
TP 150-650/4	0.1	0.1	0.1	0.8	1.4	3.1
TP 200-270/4	0.1	0.1	0.1	0.8	1.4	3.1
TP 200-280/4	0.1	0.1	0.1	0.8	1.4	3.1
TP 200-380/4	0.1	0.1	0.1	0.8	1.4	3.1
TP 200-420/4	0.1	0.1	0.1	0.8	1.4	3.1
TP 200-450/4	0.1	0.1	0.1	0.8	1.4	3.1
TP 200-510/4	0.1	0.1	0.1	0.8	1.4	3.1
TP 200-560/4	0.1	0.1	0.1	0.8	1.4	3.1
TP 200-620/4	0.1	0.1	0.1	0.8	1.4	3.1
TP 250-270/4	0.1	0.1	0.1	0.8	1.4	3.1
TP 250-320/4	0.1	0.1	0.1	0.8	1.4	3.1
TP 250-370/4	0.1	0.1	0.1	0.8	1.4	3.1
TP 250-490/4	0.1	0.1	0.1	0.8	1.4	3.1
TP 250-540/4	0.1	0.1	0.1	0.8	1.4	3.1
TP 250-600/4	0.1	0.1	0.1	0.8	1.4	3.1
TP 250-660/4	0.1	0.1	0.1	0.8	1.4	3.1
TP 300-590/4	0.4	0.6	1.1	1.8	2.4	4.1
TP 300-670/4	0.4	0.6	1.1	1.8	2.4	4.1
TP 300-750/4	0.3	0.5	1.0	1.8	2.3	4.0
TP 400-470/4	0.1	0.3	0.8	1.6	2.1	3.8
TP 400-510/4	0.1	0.3	0.8	1.6	2.1	3.8
TP 400-540/4	0.1	0.3	0.8	1.5	2.1	3.8
TP 400-670/4	0.6	0.8	1.3	2.1	2.6	4.3
TP 400-720/4	0.6	0.8	1.3	2.1	2.6	4.3
TP 400-760/4	0.6	0.8	1.3	2.0	2.6	4.3

## WebCAPS

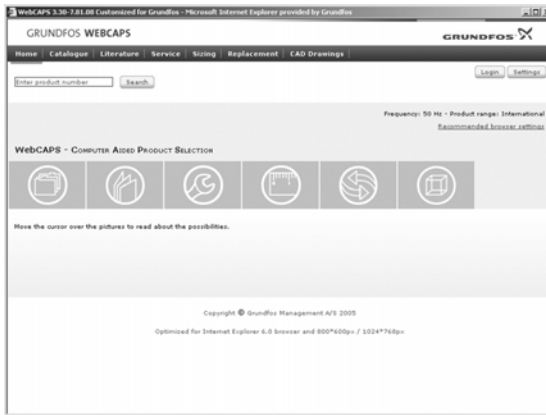

WebCAPS is a **Web**-based **Computer Aided Product Selection** program available on [www.grundfos.com](http://www.grundfos.com).

WebCAPS contains detailed information on more than 185,000 Grundfos products in more than 20 languages.

In WebCAPS, all information is divided into 6 sections:

- Catalogue
- Literature
- Service
- Sizing
- Replacement
- CAD drawings.

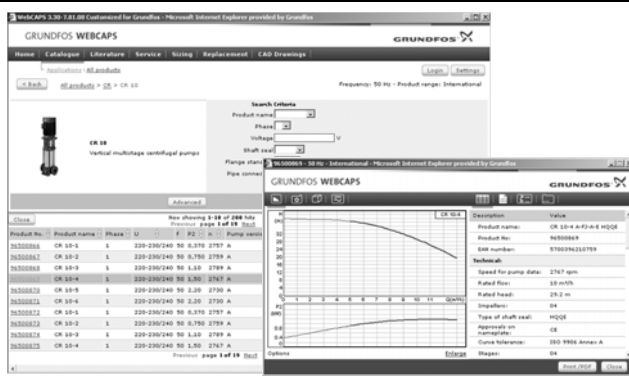

### Catalogue

This section is based on fields of application and pump types, and contains

- technical data
- curves (QH, Eta, P1, P2, etc.) which can be adapted to the density and viscosity of the pumped liquid and show the number of pumps in operation
- product photos
- dimensional drawings
- wiring diagrams
- quotation texts, etc.

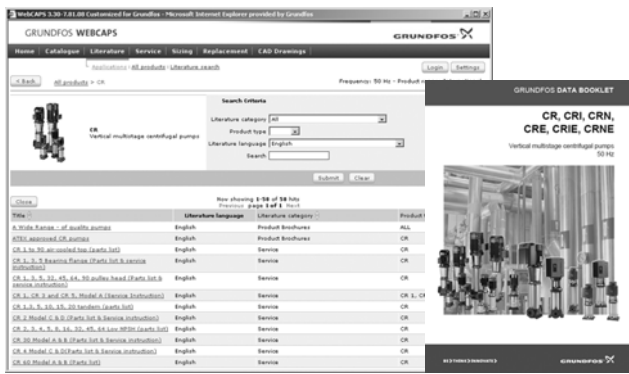

### Literature

In this section you can access all the latest documents of a given pump, such as

- data booklets
- installation and operating instructions
- service documentation, such as Service kit catalogue and Service kit instructions
- quick guides
- product brochures.

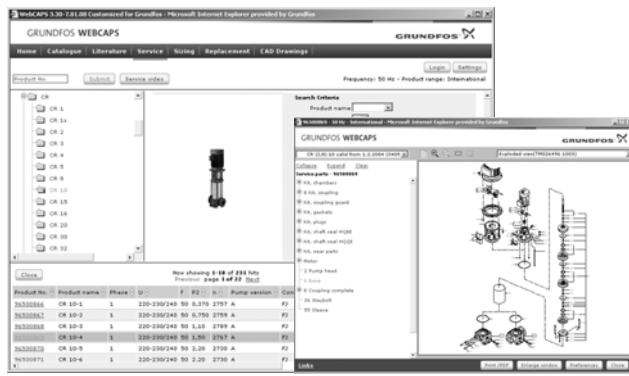

### Service

This section contains an easy-to-use interactive service catalogue. Here you can find and identify service parts of both existing and discontinued Grundfos pumps. Furthermore, this section contains service videos showing you how to replace service parts.



## Sizing

This section is based on different fields of application and installation examples, and gives easy step-by-step instructions in how to

- select the most suitable and efficient pump for your installation
- carry out advanced calculations based on energy consumption, payback periods, load profiles, life cycle costs, etc.
- analyse your selected pump via the built-in life cycle cost tool
- determine the flow velocity in wastewater applications, etc.



## Replacement

In this section you find a guide to selecting and comparing replacement data of an installed pump in order to replace the pump with a more efficient Grundfos pump. The section contains replacement data of a wide range of pumps produced by other manufacturers than Grundfos.

Based on an easy step-by-step guide, you can compare Grundfos pumps with the one you have installed on your site. When you have specified the installed pump, the guide will suggest a number of Grundfos pumps which can improve both comfort and efficiency.

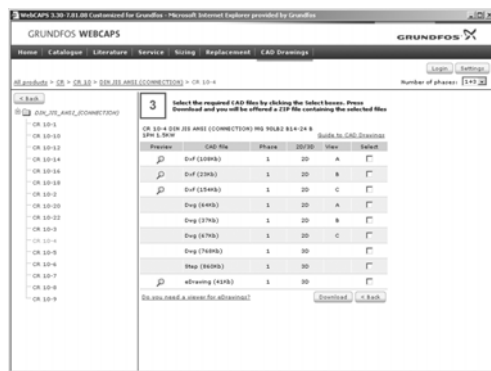

## CAD drawings

In this section it is possible to download 2-dimensional (2D) and 3-dimensional (3D) CAD drawings of most Grundfos pumps.

These formats are available in WebCAPS:

2-dimensional drawings:

- .dxf, wireframe drawings
- .dwg, wireframe drawings.

3-dimensional drawings:

- .dwg, wireframe drawings (without surfaces)
- .stp, solid drawings (with surfaces)
- .eprt, E-drawings.

## WinCAPS



Fig. 43 WinCAPS CD-ROM

WinCAPS is a **Windows-based Computer Aided Product Selection** program containing detailed information on more than 185,000 Grundfos products in more than 20 languages.

The program contains the same features and functions as WebCAPS, but is an ideal solution if no Internet connection is available.

WinCAPS is available on CD-ROM and updated once a year.



V7124417 0809	GB
Repl. V7124417 1008	

Subject to alterations.