



atac

ATAC Solutions Ltd is a leading environmental engineering company based in Maidstone, United Kingdom.

ATAC Solutions is known for its state-of-the-art liquid collection fleet and its expertise in providing bespoke turnkey wastewater process solutions.

With a focus on sustainability and accreditation in ISO 9001 & ISO 14001, the company serves domestic and industrial clients across the South-East and London.

ATAC Solutions Ltd,
Unit A9, Loc 8 Business Park, Ashford Road,
Hollingbourne, Maidstone, England, ME17 1WR

 [atacsolutions.com](https://www.atacsolutions.com)
 01622 882400

Axiom Water companies

Phone
Fax

DrainLift L 2/15 C 3~
System : Lifting plant



Customer

Project

Customer no.

Project no.

Contact

Position no.

Care of

Location

Date 16/07/2012

Page 1 / 2

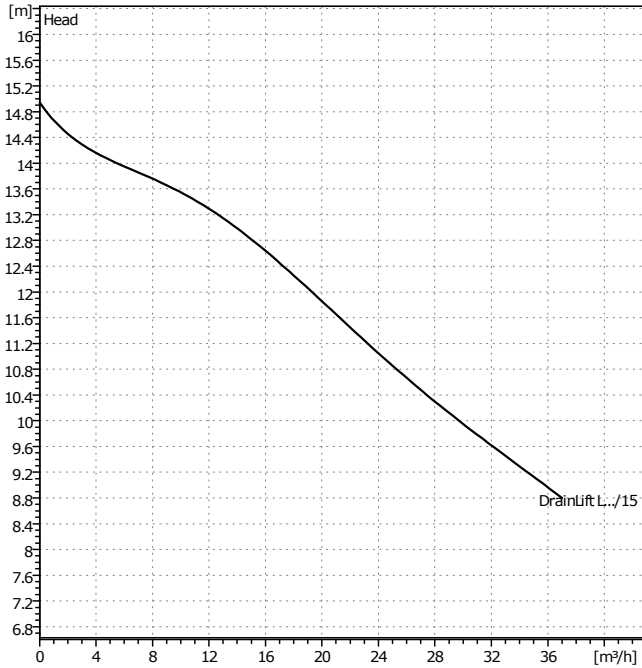

Requested data

Flow	0	m ³ /h
Head	0	m
Fluid	Water, pure	
Fluid temperature	20	°C
Density	0.9983	kg/dm ³
Kinematic viscosity	1.005	mm ² /s
Vapor pressure	0.02337	bar

Pump data

Make	WILO	
Type	DrainLift L 2/15 C 3~	
Pumpe type	Twin pump main standby	
Pressure rating	PN 6	
Min. fluid temperature	0	°C
Max. fluid temperature	40	°C
Operating type	S3-15%	

Hydraulic data (duty point)

Flow		m ³ /h
Head		m
Speed	0	1/min
Impeller size	102	mm

Materials / Shaft seal

Tank	Resin
Impeller	Resin
Motor	Stainless steel

Dimensions per pump

mm

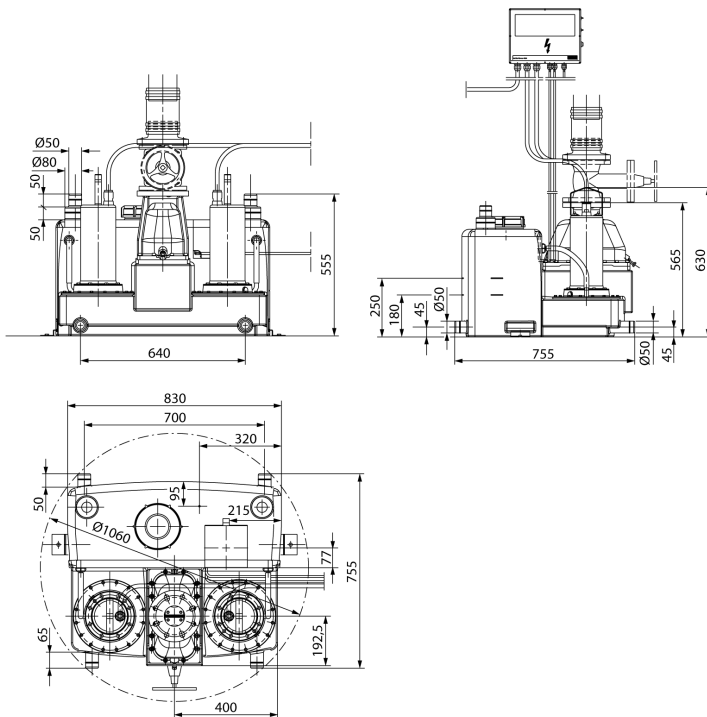

Suction side	-	
Discharge side	DN 80	
Weight	85	kg
Free passage	40	mm

Motordata per Motor/Pump/

Power input P1	3.8	kW
Nominal speed	2900	1/min
Rated voltage	3~400 V, 50 Hz	
Max. current	6.9	A
Degree of protection	IP 67	
Permitted voltage tolerance	+/- 10%	

Item no. of standard version 2519513

Phone
Fax

DrainLift L 2/15 C 3~
System : Lifting plant



Customer
Customer no.
Contact
Care of

Project
Project no.
Position no.
Location

Page 2 / 2
Date 16/07/2012

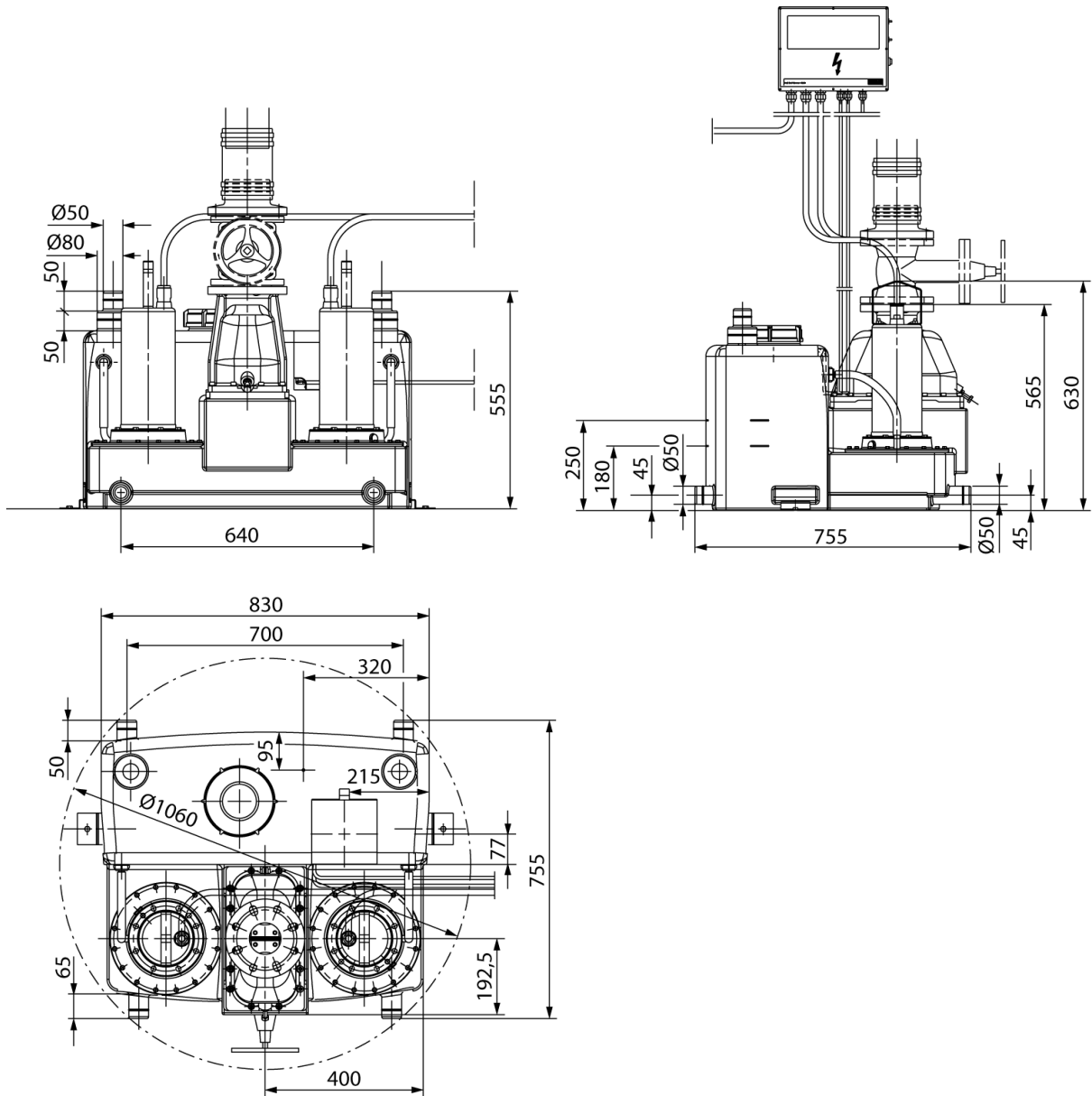

Standard
Suction side -
Discharge side DN 80

Dimensions mm